

1989



C A T A L O G

THE FINEST RADIO CONTROLLED MODELS

ENGLISH/SWEDISH

KYOSHO®
THE FINEST RADIO CONTROL MODELS



www.dirtburners.com



OFF ROAD RACE CAR
BUBBY RADIO CONTROL

KYOSHO
RACING
TEAM

www.dirt-burbs.com

INDEX THE FINEST RADIO CONTROLLED MODELS

ELECTRIC VEHICLES/MOTORCYCLES

GRAND PRIX RACING BIKES.....	8
F-1 RACERS	10
MINI STOCKERS	12
BAJA-BUGS	14
RACEWAY KIT/OPTION PARTS	16
TURBO OPTIMA 14 X	16
SKY BOMBER 14 X	18
NS-3 SUPER Ni-Cd BATTERY/AC CHARGER	19
DOUBLE DARE 4 WDS	21
HI-RIDER CORVETTE	22
BIG BRUTE	23
NITRO BRUTE	23
RAIDER 2 WD	26
MAXXUM FF	28
ULTIMA	30
TURBO ULTIMA	32
ULTIMA PRO	34
AERO STREAK 4 WD	38
SHADOW 4 WD	40
OPTIMA MID	42
TURBO OPTIMA MID	44
TURBO OPTIMA MID SE	45
OPTIMA MID CUSTOM	46
OPTIMA MID CUSTOM SPECIAL	48
TURBO ROCKY	49
HONDA CR-X	52
PEUGEOT 205	52
PLAZMA MKIII KS-2	54
PLAZMA MKIII LIMITED	54
AXIS EX	56
THE BLIZZARD	58

GAS VEHICLES

TOYOTA SUPRA	62
FORD RS-200	62
STINGER 4 WD	64
ASSAULT	65
BURNS 4 WD	66
FANTOM 21-4 iS	68

ELECTRIC PLANES

PETIT FANTASY M 20	71
PETIT DREAMIN 850	72
PETIT BALLAD 900	73
PETIT ROBIN 850	73
PETIT BREEZIN 1200	73
FLASH EP	76
CESSNA 177 CARDINAL M 36	78
ZERO FIGHTER M 36	79
P-51 D MUSTANG M 36	79
VALENCIA 1800	80
ETUDE 1200	81
DUET 1200	82
MELODY 1500	83
MELODY MOTOR PYLON	84
EXPRESS M 29	85

GAS PLANES

FLASH 10	88
CESSNA 177 CARDINAL 10	89
049 TYPHOON	90
049 SKY RALLY	91
PATRICIA 10	92
09 ZERO FIGHTER	93
PRELUDE 10	94
PRELUDE 20	94
BELLANCA SUPER DECATHLON	95
CESSNA SKYHAWK 172	95
ACROSKY	97
CESSNA 188 AGWAGON	98
FA-200 AERO SUBARU	98
RV-3 HOMEBUILT	98
PROUD BIRD	98
MISS AMERICA	98
SUPER CHIPMUNK	98
CAP 21	98

ENGINE-POWERED HELICOPTERS

CONCEPT 30 DX	101
CONCEPT 30 SE	101
SPECIAL ITEMS	103

BOATS/YACHTS

JET STREAM 800	106
TOM'S RIVER	108
FLORIDA	109
CASABLANCA	110
OCEAN 500	111
RIVIERA	111
FAIRWIND	112

POP CRAFT

MOAI	144
HEL-LIGHT	145
TENTOU MUSHI	145

MISC

NiCd BATTERIES	114
CHARGERS	116
MOTORS	118
MOTOR CHECKER	120
MOTOR BREAK-IN MACHINE	120
OPTION HOUSE PARTS	122
SPECIAL PARTS	124
SOLDERING IRON/HANDY IRON	130
POLYCA COLOR PAINT	131
HOBBY SHEARS & SANDER	131
MICRON LINE TAPE	131
BLITZ STARTER	132
POWER DIVIDER	132
K&B STARTER PACK	133
K&B HANDY FUELS	133
K&B GLOW FUEL/PLUGS	134
KYOSHO RACING FUELS	134
EXCELCOTE COVERING FILMS	135
SILKYCOTE COVERING MATERIALS	136
K&B PAINTS/COATING POXY	137
SPECIAL PROP DRIVE UNITS	138
DIGITAL PROPORTIONAL RADIO CONTROL SETS	139
ELECTRONIC SPEED CONTROLLERS AND ACCESSORIES	140
KYOSHO ORIGINALS	141
VIDEO TAPES	141



MOTORCYCLES & MINI ST

■ HONDA NSR 500 ■ YAMAHA YZR 500 ■ SUZUKI RGV-Γ
■ LOTUS HONDA 99T ■ McLAREN MP4/3 TAG TURBO
■ WILLIAMS HONDA ■ MERCEDES-BENZ 190E ■ BMW M3



ZE CARS

- BAJA BUGS / ULTIMA ■BAJA BUGS / TURBO OPTIMA 2WD
- BAJA BUGS / SALUTE 2WD
- TURBO OPTIMA 14X ■SKY BOMBER 14X

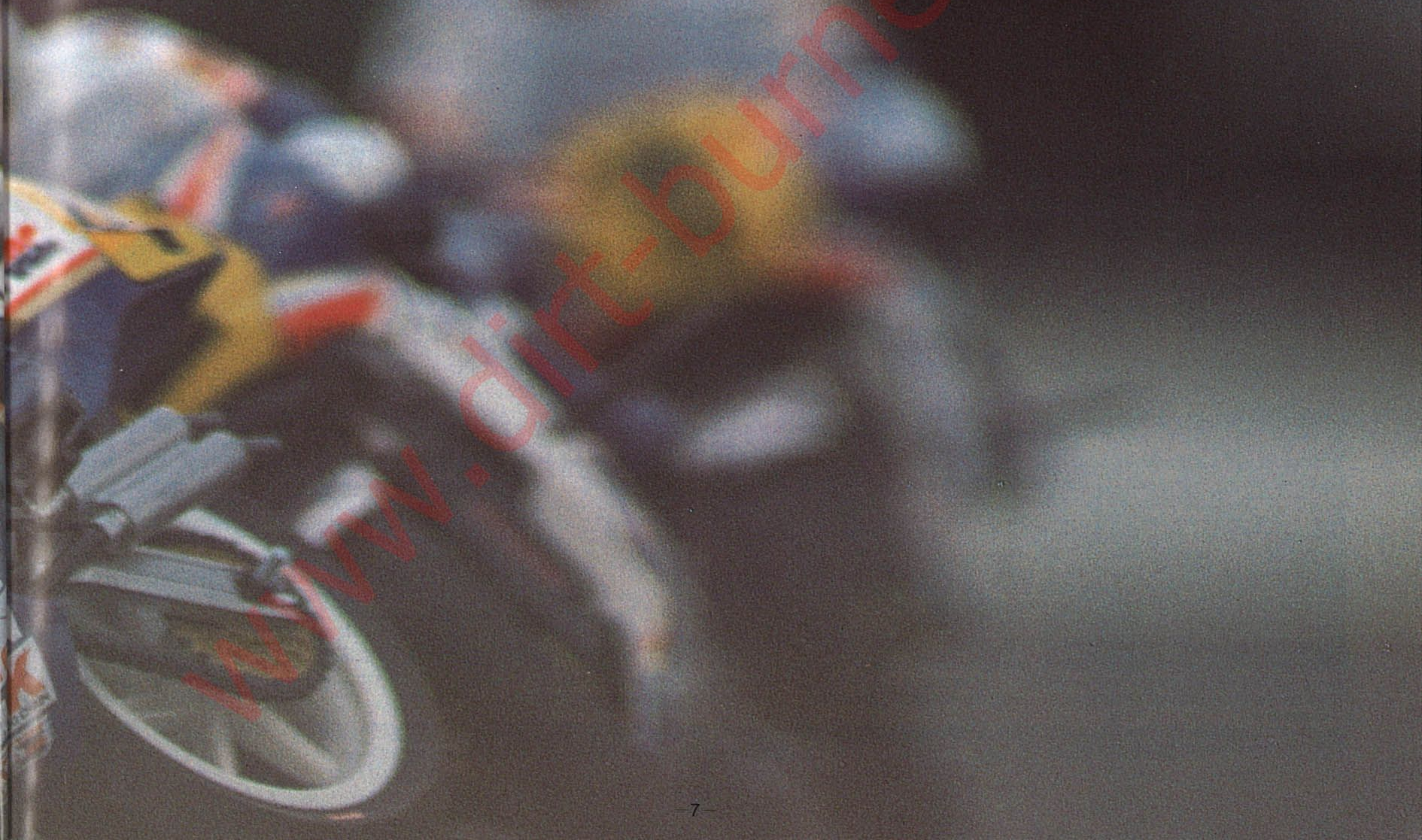



ENDAST FÖR JAPANSKA MARKNADEN.



SUZUKI RGV-Γ

MOTORCYCLE REALISM IN MINIATURE!

THE SUZUKI RGV-gamma 500 (MAIN ILLUSTRATION), AND ITS STABLEMATES, THE HONDA NSR 500 AND YAMAHA YZR 500, ARE HIGH-PERFORMANCE 1/8-SCALE RADIO CONTROLLED MOTORCYCLES THAT ARE JUST AS EASY TO DRIVE AS A MODEL CAR, AND LOTS OF FUN! THE URGE COMES FROM THE POWERFUL, COMPACT DM20 MOTOR (INCLUDED), POWERED BY A LIGHTWEIGHT 7.2V-270mAh OR 7.2V-600mAh RECHARGEABLE NICKEL CADMIUM BATTERY (NOT INCLUDED). THEY LEAN REALISTICALLY AS THEY BLAST THROUGH THE CURVES GRAND-PRIX STYLE. THE UNIQUE GYRO-STEERING SYSTEM MAKES IT EASY TO OPERATE, EVEN FOR BEGINNERS (LIGHTWEIGHT FRONT WHEEL AVAILABLE FOR HIGH PERFORMANCE). REAL CHAIN DRIVE, WITH CHOICE OF THREE FINAL DRIVE RATIOS (GEARS INCLUDED). STRONG GLASS FIBER-REINFORCED FRAME, POLYCARBONATE AND NYLON FAIRING, TANK, AND SEAT PARTS. REALISTIC DRIVER. CUSTOM PAINT SET WITH MATCHED COLORS AVAILABLE FOR EACH MODEL.

REQUIRED FOR OPERATION / RECOMMENDED FOR BEST APPEARANCE

●TWO CHANNEL RADIO CONTROL SET WITH SERVO FOR MINIATURE CARS AND ELECTRONIC SPEED CONTROLLER ●7.2V-270mAh OR 7.2V-600mAh NiCd BATTERY AND CHARGER ●PAINT SET

Technical Data

①Length/270mm (10.6in) ②Width/81mm (3.2in) ③Height/154mm (6.1in) ④Wheelbase/185mm (7.3in) ⑤Tires/(F)φ78×18mm; (R)φ86×23mm ⑥Total weight/680g (24.7oz) ⑦Gear ratio/13.8: 1~19.3: 1 ⑧Motor/LeMANS DM20 (Included) ⑨Battery/7.2V-270mAh (Not included) ⑩Radio/2-Channel (Not included)

HAR DU ALLTID DRÖMT OM ATT KÖRA ROADRACING ?

Börja då med en radiostyrd racer så får Du all spänning till ett mycket överkomligt pris! Ladda ack-paketet. Ställ den på startlinjen och ge gas. I hög fart är den minst lika stabil som sina förebilder. Lägg ner den maximalt genom den långa fullfartböjen och ge sedan järnet ut på raksträcken! Hur fungerar den då tekniskt? Jo, nyckeln till det hela är en patentsökt konstruktion där gaffeln tillas varvid tyngpunkten förskjuts och styrgeometrin gör att motorcykeln svänger. Låter det krångligt? Glöm det då - för det fungerar!! Den drivs av en liten snabb elmotor som får sin ström från ett uppladdningsbart ack-paket. Materialet är olika konstruktionsplaster och naturligtvis är det en riktig kedja som driver bakhjulet! Realism även i detaljerna. Racingslicks av gummi och tre olika utväxlingar medföljer.

DET HÄR BEHÖVS FÖRUTOM BYGGSATSEN

En Impuls II radio, ett ack-paket 7.2V/270(600)mAh, laddare för ack-paketet och färg eller original färgsats.

GRAND PRIX RACING BIKES

ELECTRIC POWERED MOTORCYCLES

YAMAHA YZR 500 No. 3006
 HONDA NSR 500 No. 3002
 SUZUKI RGV-Γ No. 3004

1:8 SCALE



YZR TEAM COLORS ILLUSTRATED ARE FOR JAPANESE MARKET ONLY.



SET ILLUSTRATED IS FOR JAPAN MARKET ONLY.
 SETS OF PAINTS EXACTLY MATCHED TO THE
 COLOR SCHEMES OF THE MOST FAMOUS RACING
 TEAMS ARE AVAILABLE FOR DECORATING EACH
 OF THESE MACHINES.

I butiken finner Du alla de olika enheterna som behövs för att göra roadracern körfärdig.

Fråga efter ett komplett paket (säljs i Sverige med Kyosho original Impuls II radio).

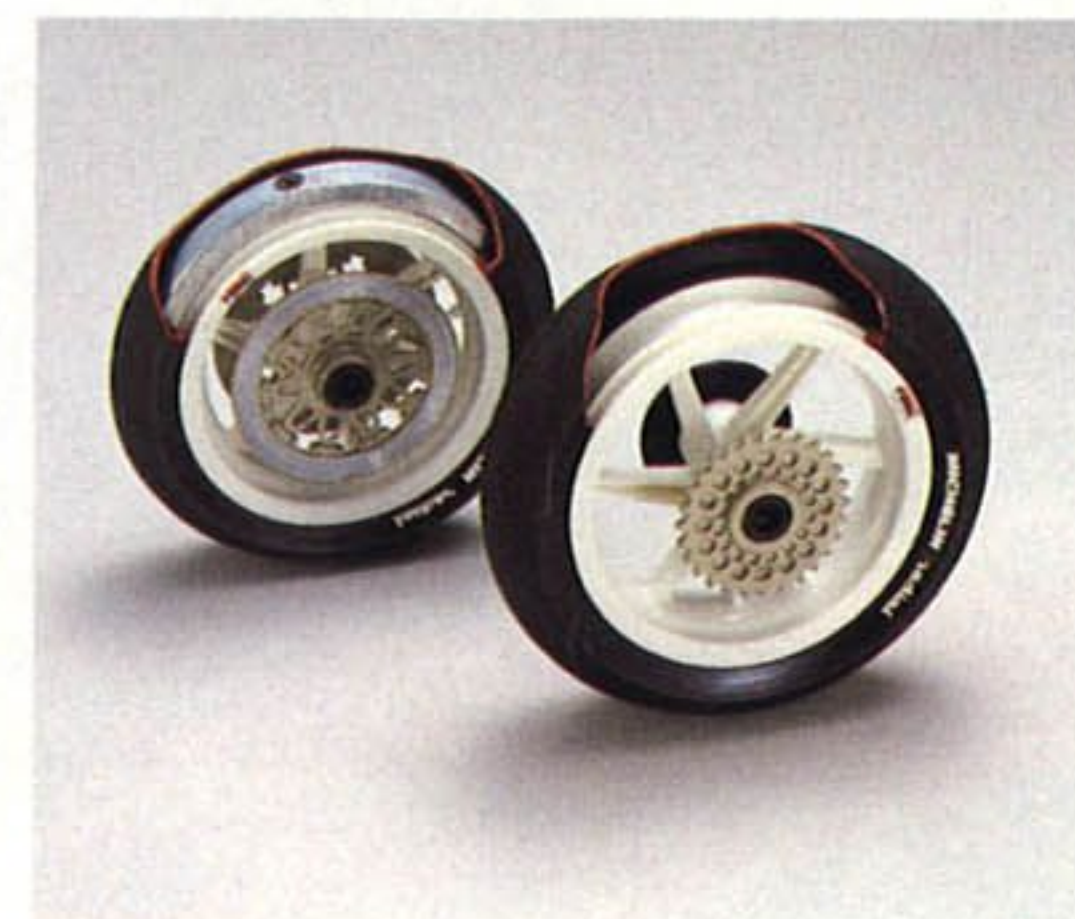

TUBELESS SEMI-PNEUMATIC SYNTHETIC RUBBER TIRES. GYRO-STEERING FRONT WHEEL UNIT.

Lågtrycksdäck av syntetiskt gummi. Gyrovikt i framhjulet!



FUNCTIONING FRONT SUSPENSION WITH INTERNAL SPRINGS. REALISTIC ACTION.

Framgaffeln med inbyggda fjädrar.



DRIVE TO REAR WHEEL BY REAL ROLLER CHAIN. REALISTIC SLICK RACING TIRES.

En riktig kedja driver det racingslicks utrustade bakhjulet.



RIGID MONOCOQUE FRAME SUPPORTS SUSPENSION AND RUNNING GEAR, AIDS EASY ASSEMBLY.

Ramen är konstruerad som en stabil sk monocoque.



POWERFUL 7.2V-270mAh NiCd BATTERY (NOT INCLUDED) CLIPS UNDER CHASSIS FOR LOW CG.

Ack-paketet är monterat under ramen för lägsta tyngdpunkt.



Manufactured under licence from Team Lotus International Ltd.



Manufactured under licence from McLaren International Ltd.



Manufactured under licence from Williams Grand Prix Engineering Ltd.



LIVING ROOM GRAND PRIX RACING THRILLS!

GRAND PRIX RACING COMES TO THE LIVING ROOM! THESE FINELY DETAILED VEHICLES ARE MINIATURE IN SIZE ONLY. THE PERFORMANCE IS FULL SCALE! MOVE THE TRANSMITTER STICK FORWARD AND THEY GO! THE CHASSIS IS STIFF GLASS-POLYESTER. THE SUSPENSION IS INDEPENDENT ON ALL WHEELS, WITH FUNCTIONAL FRICTION SHOCKS, AND IS COMPLETELY SCALE IN APPEARANCE AND GEOMETRY. (THE DESIGNS ARE REPRODUCED BY SPECIAL PERMISSION.) THE PERFORMANCE COMES FROM THE CUSTOM-MADE DM20 MINIATURE CAR MOTOR AND A 7.2V-270mAh NiCd BATTERY. (RECHARGEABLE IN A MAXIMUM OF 15 MINUTES WITH CHARGER #2312. MOTOR INCLUDED IN KIT. BATTERY AND CHARGER NOT INCLUDED.) CHOICE OF FOUR GEAR RATIOS TO MATCH CAR TO TRACK CONDITIONS. CAN BE RACED IN SMALL AREAS.

REQUIRED FOR OPERATION / RECOMMENDED FOR BEST APPEARANCE (NOT INCLUDED)

- RADIO CONTROL SYSTEM/TWO CHANNEL WITH MICRO RECEIVER/SPEED CONTROLLER AND MINI SERVO
- BATTERY: 7.2V-270mAh NiCd "SQUARE PACK" ●CHARGER ●PAINT SET

Technical Data

①Length/238mm (9.4") ②Width/118mm (4.6") ③Height/60mm (2.4") ④Wheelbase/150mm (5.9") ⑤Ground clearance/6mm (0.24") ⑥Front track/97mm (3.8") ⑦Rear Track/93mm (3.7") ⑧Weight/360g (12.7oz) ⑨Tires/(F)φ34×18.5mm; (R)φ36×24mm ⑩Gear ratios/5.33: 1 TO 8.7: 1 ⑪Motor/LeMans DM20 (Included) ⑫Battery/7.2V-270mAh NiCd Square Pack (Not included) ⑬Radio control system/miniature set with micro servo and electronic speed controller (not included)

FORMULA 1 RACING I VARDAGSRUMMET ?

Ja, nu kan Du faktiskt på en rimlig yta köra radiostyrd F1 racing med bilar som inte är mer än drygt 20 cm långa! En vass LeMans DM-20 motor och ett styvt chassie av glasfiber med separat upphängda hjul ger en fantastisk väghållning. Den är naturligvis utrustad med fungerande stötdämpare som tillsammans med kraftiga svampgummislicks ger bästa grepp i alla situationer.

Tro inte att de här bilarna går att jämföra med traditionell miniracing. Känslan att köra radiostyrt är någonting helt annat och långt mer fascinerande och spännande men ändå utan att kräva jättestyrymmen!

DET HÄR BEHÖVS FÖRUTOM BYGGSATSEN

En Impuls II radio, ett ackpaket 7.2V/270mAh SQ samt en laddare. Dessutom behövs färg.

F-1 RACERS

ELECTRIC POWERED SCALE F-1 RACING CARS

McLAREN MP4/3 TAG TURBO No. 3176

LOTUS HONDA 99T No. 3175

WILLIAMS HONDA No. 3177

1:18 SCALE



SET ILLUSTRATED IS FOR JAPAN MARKET ONLY. SETS OF PAINTS EXACTLY MATCHED TO THE COLOR SCHEMES OF THE MOST FAMOUS RACING TEAMS ARE AVAILABLE FOR DECORATING EACH OF THESE MACHINES.

Setet Du ser till vänster säljs inte i Sverige. Fråga i Din butik efter kompletta set med Impuls II radio.

- ① FRONT SUSPENSION ARM. SCALE GEOMETRY.
- ② SCALE-LOOKING REAR SUSPENSION.
- ③ GLASS-REINFORCED POLYESTER CHASSIS. STRONG, LIGHT.
- ④ DIFFERENTIAL.
- ⑤ HIGH-PERFORMANCE LeMANS DM20 MOTOR (INCLUDED).
- ⑥ "SQUARE PACK" 7.2V-270mAh NiCd BATTERY PACK (NOT INCLUDED).
- ⑦ TWO-CHANNEL RADIO SET FOR MINIATURE CARS (NOT INCLUDED).
- ⑧ SPONGE TIRES FRONT/REAR FOR GOOD TRACTION ON ASPHALT OR CARPET.

- 1 Skälriktig framvagnsgeometri.
- 2 Bakhjulsupphängning med triangelstag.
- 3 Chassieplatta av lätt glasfiberarmerad polyester.
- 4 Differential väl skyddad i sitt växelhuss.
- 5 Vass LeMans DM20 motor ger kraften.
- 6 Snabbt bytbart ack-paket.
- 7 RS-enheten med mottagare och fartreglage.
- 8 Däck av skumgummi ger bra grepp på asfalt och matta.

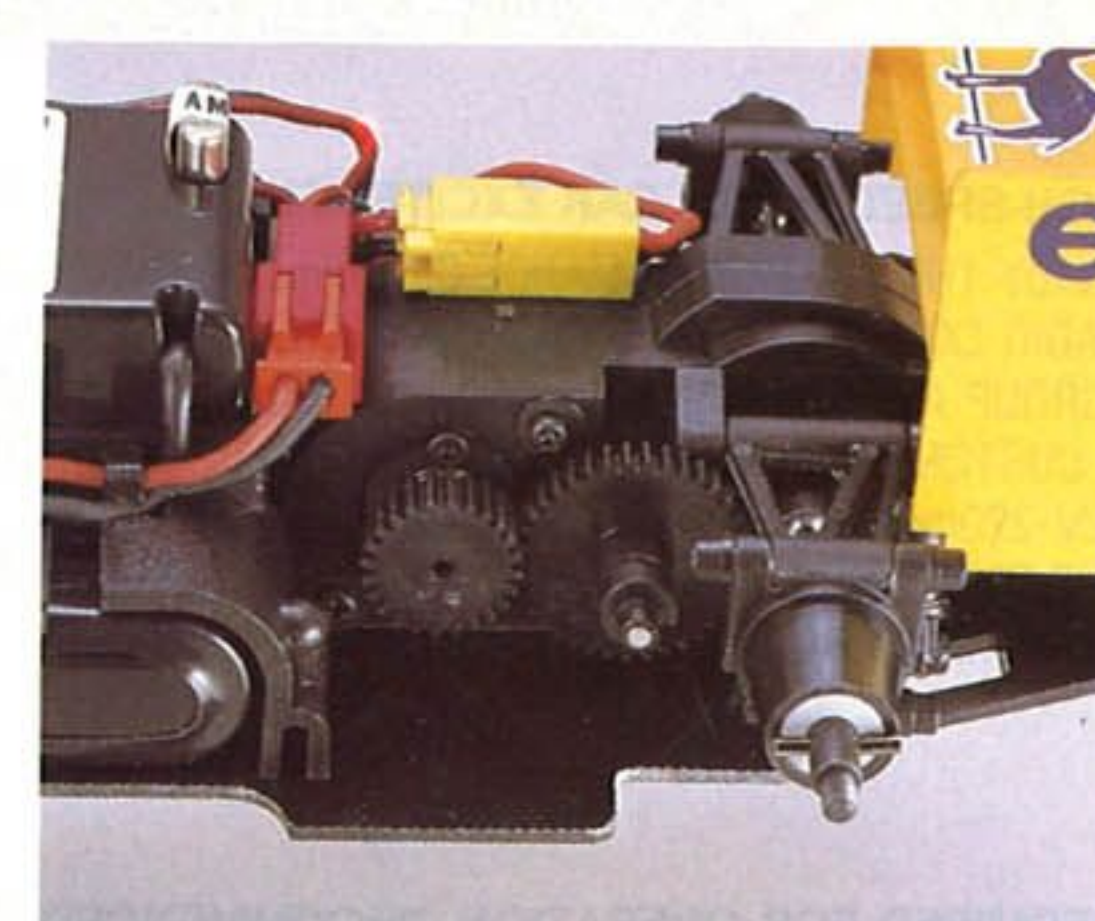
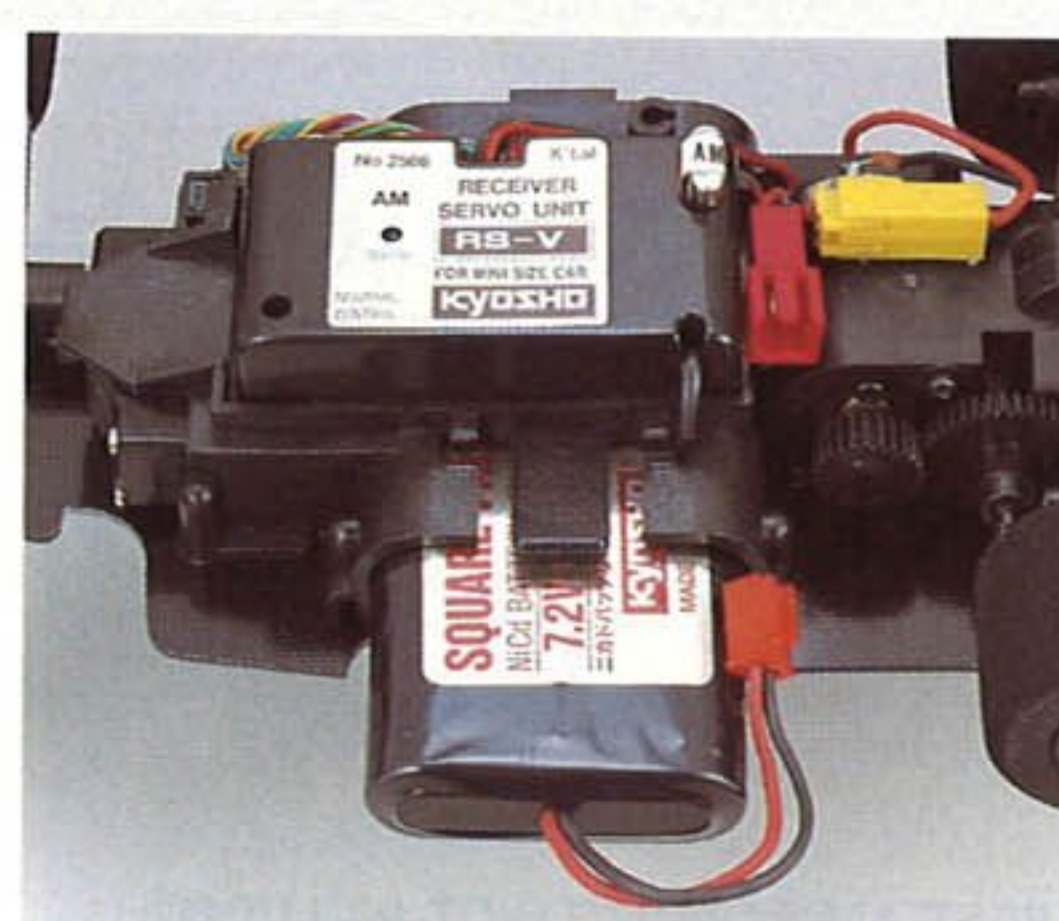
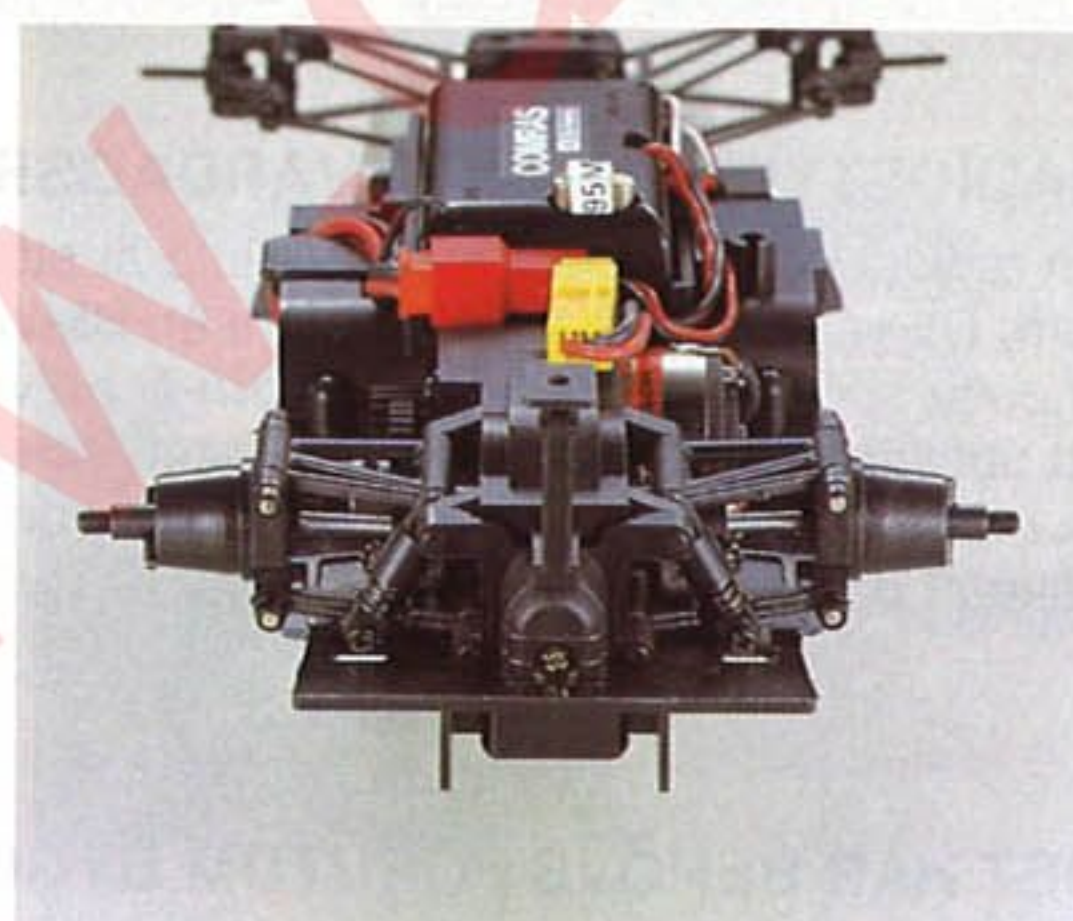
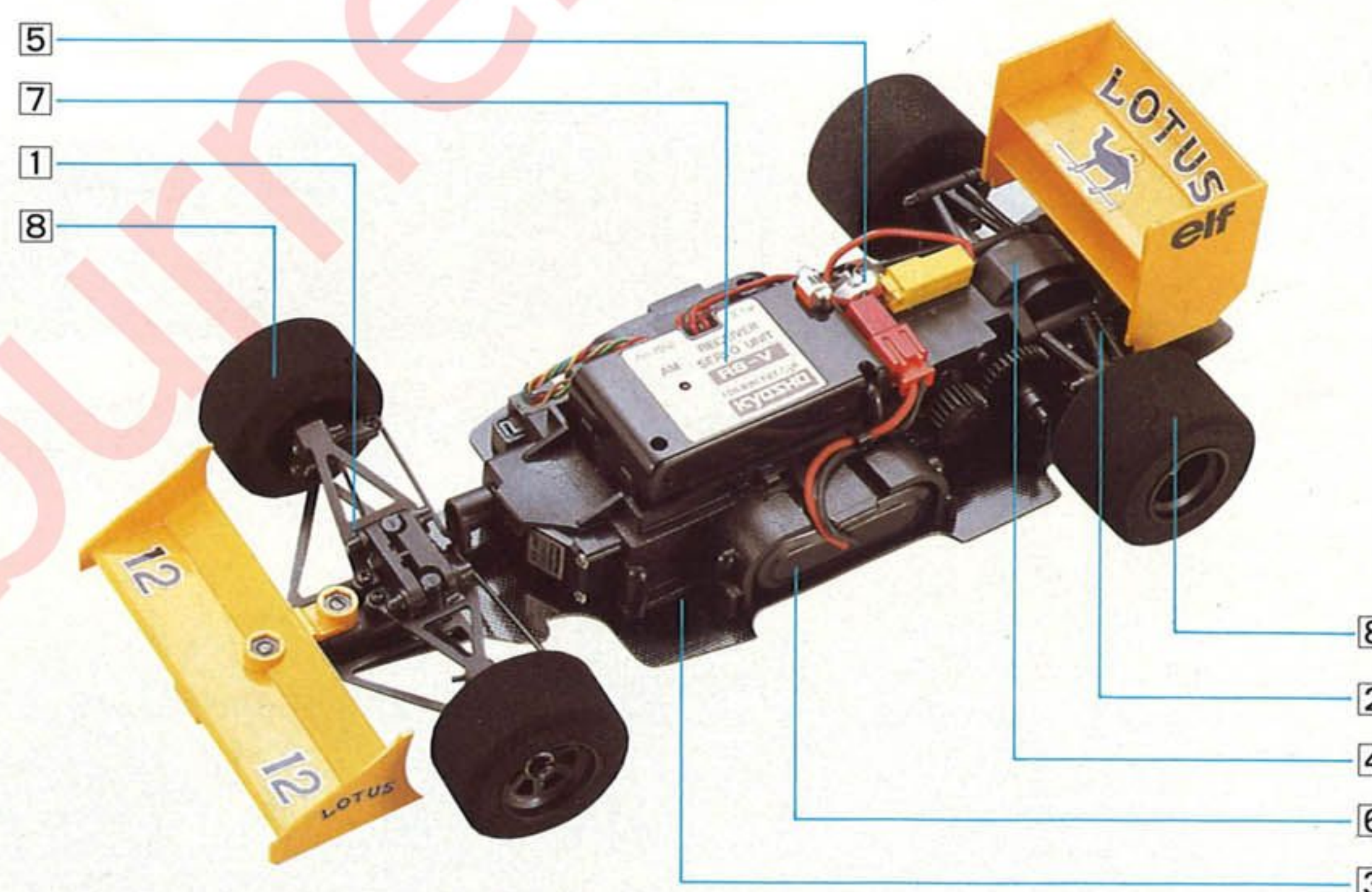

FRONT SUSPENSION IS TRUE SCALE IN GEOMETRY. STRONG STEEL A-ARMS. REALISTIC APPEARANCE. REAR SUSPENSION HAS SCALE LOOK AND TRUE GEOMETRY. EFFECTIVE ACTION.

Den riktigt skalamässiga framvagnen och den effektiva bakvagnen ger den här F1 modellen bästa väghållning. Teknik i miniatyr!

BATTERY CLICKS INTO PLACE AND IS REMOVED EASILY. SQUARE PACK BATTERY USABLE IN OTHER MAKER'S CARS.

Ack-paketet är snabbt utbytt och sitter fast med snäplås.

DRIVE PINION ON MOTOR CAN BE CHANGED TO ALTER DRIVE RATIO. INTERNAL GEARS GIVE TWO MORE RATIOS.

Motordrevet kan bytas för ändrad utväxling.



HIGH-SPEED RALLY CAR EXCITEMENT!

ENJOY THE HOT PERFORMANCE OF SOME OF THE FASTEST ROAD CARS IN THE WORLD IN 1/20-SCALE UNDER RADIO CONTROL. ACCELERATE AND STEER THROUGH THE BENDS! YOU CAN DO IT WITH THESE MINIATURE "GROUP A TOURING" CARS IN A LARGE LIVING ROOM OR BASEMENT! HOURS OF FUN! THE POWERPLANT IS A CUSTOM-MADE DM20 MOTOR (INCLUDED; DM20BB WITH BALL BEARINGS OPTIONAL), ENERGIZED BY A 7.2V-270mAh NiCd BATTERY. (RECHARGEABLE IN ONLY A FEW MINUTES. BATTERY INCLUDED IN KIT.) DESPITE THE SMALL SIZE, THE SUSPENSION IS INDEPENDENT ON ALL FOUR WHEELS, WITH EFFECTIVE FRICTION-TYPE SHOCK ABSORBERS.

REQUIRED FOR OPERATION/RECOMMENDED FOR BEST APPEARANCE (NOT INCLUDED)

- RADIO CONTROL SYSTEM/TWO CHANNEL WITH MICRO RECEIVER/SPEED CONTROLLER AND MINI SERVO
- CHARGER ●POLYCA COLOR PAINT ●MICRON LINE STRIPING TAPE

Technical Data

①Length/220mm (8.7") ②Width/114mm (4.5") ③Height/73mm (2.9") ④Wheelbase/132mm (5.2") ⑤Ground clearance/8mm (0.3") ⑥Front track/94mm (3.7") ⑦Rear track/95mm (3.7") ⑧Weight/370g (13oz) ⑨Tires (F/R)/φ31×16mm ⑩Gear ratio/8.1:1 ⑪Motor/LeMans DM20 (Included) ⑫Battery/7.2V-270mAh ("stick" type; included) ⑬Radio control system/miniature 2-channel type with micro servo and electronic speed controller (not included)

RADIOSTYRD RACING I VARDAGSRUMMET

En radiostyrd Grupp A racer som inte är större än att den går att köra i ett stort vardagsrum. Du väljer själv om Du vill ratta en BMW M3 eller en Mercedes 190-2.3! Båda är lika snabba i den här lilla skalan. Motorn är en vass liten LeMans DM20 som får sin kraft från ett uppladdningsbart ack-paket. Laddningen tar 15 - 25 minuter och körtiden är ungefär lika lång. Skaffa ett extra ack-paket så kan Du köra praktiskt taget hela tiden! Du byter paketet på några sekunder - sen bär det iväg ut på banan igen!

DET HÄR BEHÖVS FÖRUTOM BYGGSATSEN

En Impuls II radio med RS-enhet samt ett ack-paket 7.2V/270mAh med tillhörande laddare. Dessutom behövs färg.

MINI STOCKERS

ELECTRIC POWERED RACING CARS

BMW M3 No. 3194
 MERCEDES BENZ 190E No. 3195

1:20 SCALE



- 1 WISHBONE/PARALLEL ARM INDEPENDENT SUSPENSION FRONT/REAR.
- 2 EFFECTIVE, LIGHTWEIGHT ALUMINUM FRICTION-TYPE SHOCK ABSORBERS.
- 3 STRONG, LIGHT ALUMINUM HALF-SHAFTS.
- 4 CUSTOM HIGH-PERFORMANCE LeMANS DM20 MOTOR (INCLUDED).
- 5 SEMI-PNEUMATIC TIRE WITH FULLY-SCALE TREAD PATTERN.
- 6 NYLON MOTOR GUARD.
- 7 HIGH-POWER 7.2V-270mAh NiCd BATTERY (INCLUDED, WITH CHARGER).
- 8 COMBINED GEARBOX/DIFFERENTIAL WITH CLOSE-MOUNTED MOTOR.

- 1 Hjulupphängning med triangel stag både fram och bak.
- 2 Stötdämpare av friktionstyp runt om.
- 3 Lätta drivaxlar av aluminium.
- 4 Vass LeMans DM20 motor. Kullagrad finns som extra tillbehör.
- 5 Racingmönstrade gummidäck av låg-profils typ.
- 6 Motorskydds båge av stark seg nylon.
- 7 Ack-paket som snabbt går att byta mot en nyuppladdat.
- 8 Slutet växelhhus med drivning från motor via en differential till de utgående axlarna.

Belysningssats med fungerande huvudstrålkastare ingår i båda byggsatserna.

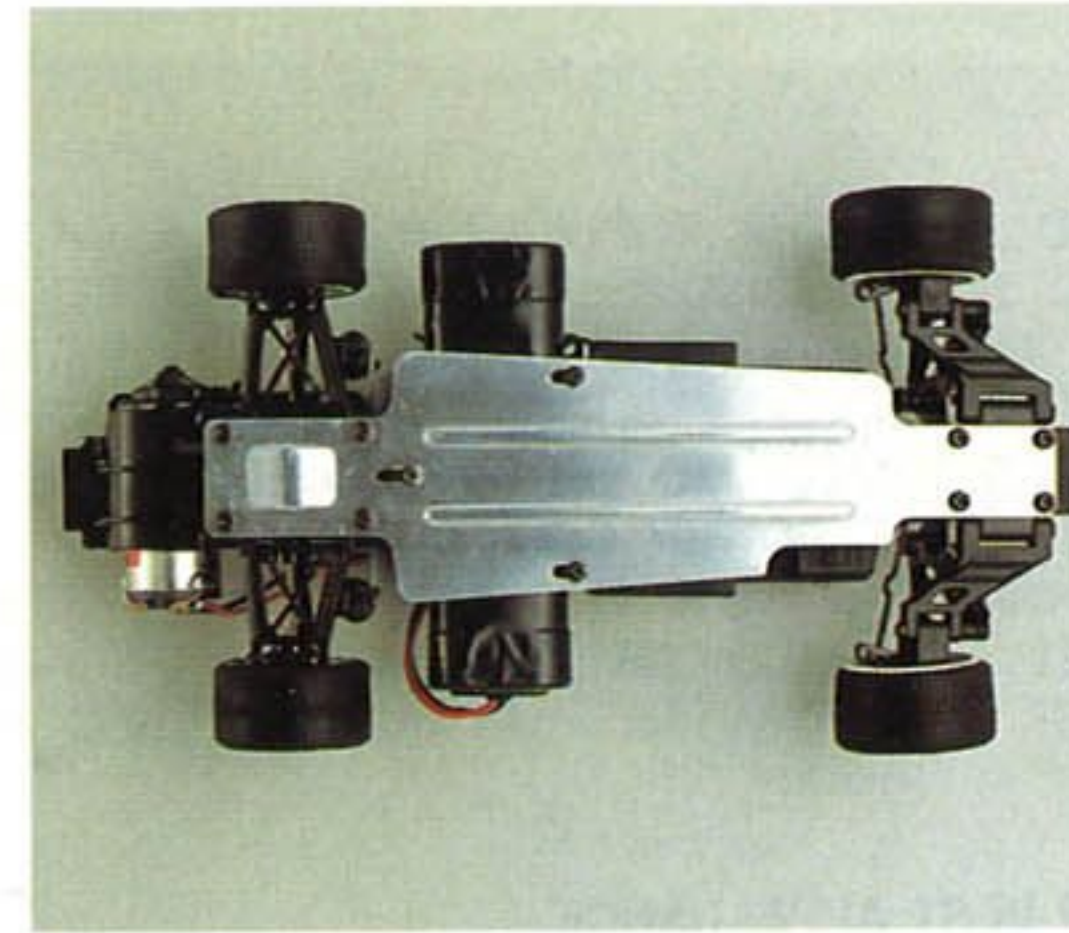
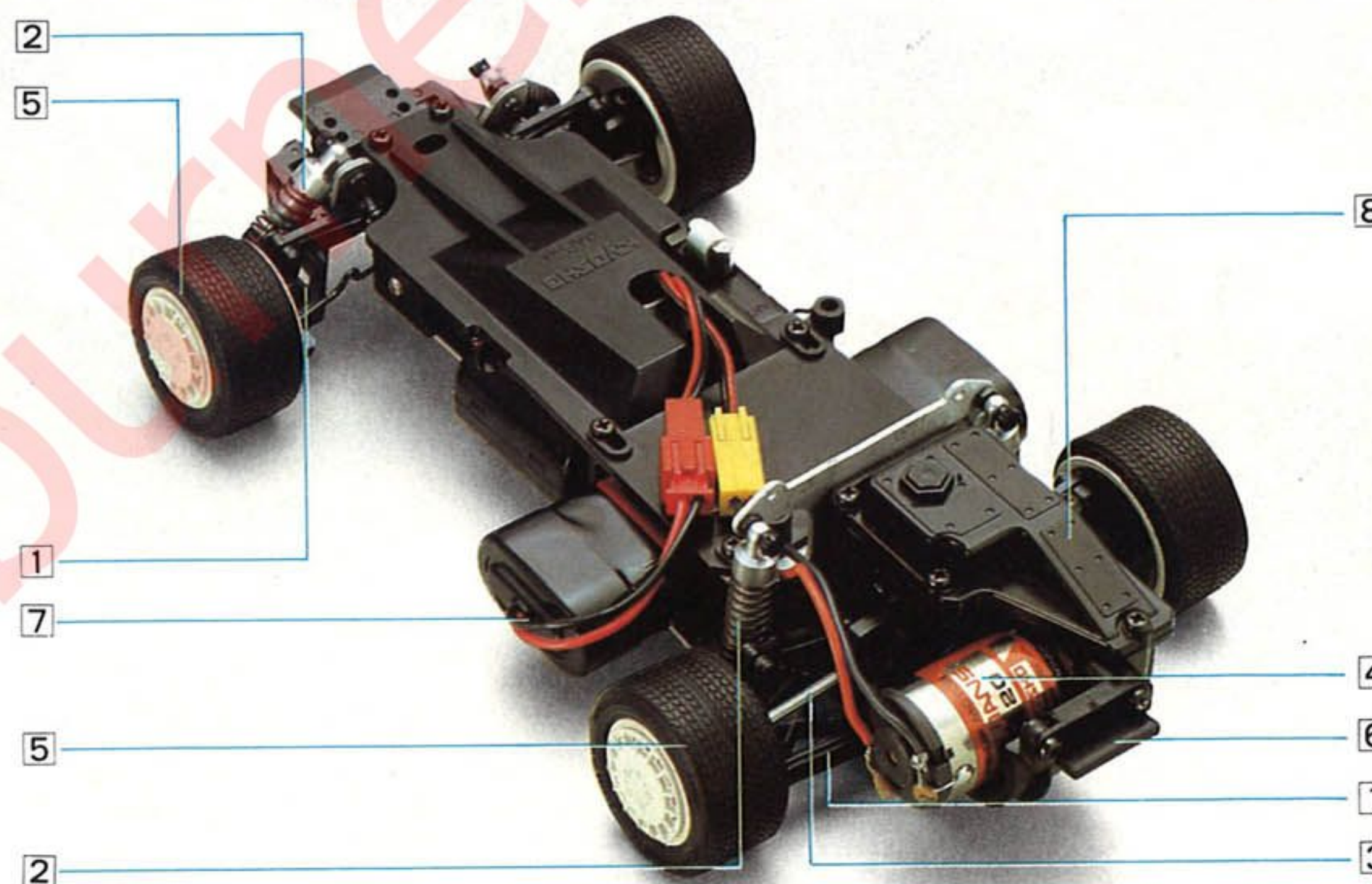

WISHBONE/PARALLEL ARM INDEPENDENT SUSPENSION FRONT/REAR FOR TOP ROADHOLDING. ALUMINUM-BODY FRICTION-TYPE SHOCK ABSORBERS ON ALL WHEELS. ALUMINUM HALF-SHAFTS.

STRONG, LIGHT ABS RADIO PLATE. RIGID ALUMINUM CHASSIS PROTECTS RADIO EQUIPMENT, BATTERY.

Chassiet av stark aluminium fungerar också som skyddsplåt vid körning utomhus. Fram och bakvagn är uppbyggda för största realism och för att erhålla bästa väghållning.



THE MOST MODELLING FUN OF THE YEAR!

WHAT'S SMALL, FAST, EXCITING, SMALL, AND FUN? THE POPULAR 1/20-SCALE BAJA BUGS MINI OFF-ROADERS! SUPER QUICK AND SUPER NIMBLE. PUSH THE "GO" STICK AND THEY'RE GONE! ALL HAVE FULLY FUNCTIONING FOUR-WHEEL INDEPENDENT SUSPENSION (WISHBONE/PARALLEL ARM) AND FRICTION-TYPE SHOCK ABSORBERS. THE "GO" COMES FROM THE HIGH-PERFORMANCE DM20 MOTOR (INCLUDED; SUPER-PERFORMANCE DM20BB AVAILABLE AS OPTION). THE POWER COMES FROM A 7.2V-270mAh NiCd BATTERY (INCLUDED, WITH CHARGER). WITH THIS COMBINATION, THE BUGS SCOOT AROUND A COURSE ALMOST AS FAST AS ORDINARY 1/10-SCALE MODELS! BECAUSE THEY ARE SO COMPACT, THEY CAN BE RUN INDOORS AND IN OTHER RESTRICTED SPACES.

REQUIRED FOR OPERATION/RECOMMENDED FOR BEST APPEARANCE

●RADIO CONTROL SET: TWO-CHANNEL MINIATURE SET WITH MICRO SERVO AND COMBINED MICRO RECEIVER/ELECTRONIC SPEED CONTROLLER ●POLYCA COLOR PAINT ●MICRON LINE STRIPPING TAPE

Technical Data

①Length/200mm (7.9in) ②Width/110mm (4.3in) ③Height/67mm (2.6in) ④Wheelbase/132mm (5.2in) ⑤Ground clearance/18mm (0.7in) ⑥Front track/88mm (3.5in) ⑦Rear track/90mm (3.5in) ⑧Tires/(F)φ38×12mm; (R)φ44×20mm ⑨Total weight/350g (12.3oz) ⑩Gear Ratio/10:1 ⑪Motor/LeMans DM20 (Included) ⑫Battery/7.2V-270mAh (Included) ⑬Radio/Two-Channel (Not included)

ELBUGGY I HALVA SKALAN !

Det här är en elbuggy som inte är längre än 20 cm! Tillräckligt liten för att gå att köra inomhus och ändå tillräckligt robust för att kunna köras utomhus. Snabb och ettrig så Du nog knappt tror Dina ögon. Det här är definitivt ingenting att förväxla med s k "lekradiobilar" utan någonting betydligt mer avancerat. Den drivs förstås av ett uppladdningsbart ack-paket som tål att laddas flera hundra gånger och styrs av en radio med flera hundra meters räckvidd! Tuff som sina storebröder men tillräckligt liten för att kunna köras inomhus.

DET HÄR BEHÖVS FÖRUTOM BYGGSATSEN

En Impuls II radio med RS-enhet, ett ack-paket 7.2V/270mAh och en laddare. Dessutom behövs färg.

BAJA-BUGS

ELECTRIC POWERED OFF-ROADERS

TURBO OPTIMA 2WD No. 3191

ULTIMA No. 3192

SALUTE 2WD No. 3193

1:20 SCALE



- 1 EFFECTIVE, LIGHTWEIGHT ALUMINUM FRICTION-TYPE SHOCK ABSORBERS.
- 2 STRONG, LIGHT ABS RADIO PLATE.
- 3 STRONG, LIGHT ALUMINUM HALF-SHAFTS.
- 4 COMBINED GEARBOX/DIFFERENTIAL WITH CLOSE-MOUNTED MOTOR.
- 5 LOW-PROFILE, HIGH-GRIP SEMI-PNEUMATIC TIRES. SPIKE REAR/RIB-TYPE FRONT.
- 6 WISHBONE/PARALLEL ARM INDEPENDENT SUSPENSION FRONT/REAR.
- 7 HIGH-POWER 7.2V-270mAh NiCd BATTERY (INCLUDED, WITH CHARGER).
- 8 STYLISH, STRONG AND LIGHT ONE-PIECE ABS WHEELS.
- 9 CUSTOM HIGH-PERFORMANCE LeMANS DM20 MOTOR (INCLUDED).
- 10 NYLON MOTOR GUARD.

- 1 Stötdämpare med hus av aluminium och utanpåliggande fjädrar.
- 2 Övre chassie av stark ABS plast.
- 3 Lätta drivaxlar av aluminium.
- 4 Växelhuset är helkapslat och skyddar även differentialen.
- 5 Bakdäck med kraftiga nabbar för maximalt grepp.
- 6 Kraftiga bärramar och separat upphängning för varje hjul.
- 7 Ack-paketet är snabbt utbytbart.
- 8 Starka lätta fälgar av ABS plast.
- 9 Vass LeMans DM20 motor för prestanda och acceleration.
- 10 Motorskydd inbyggt i chassiet.

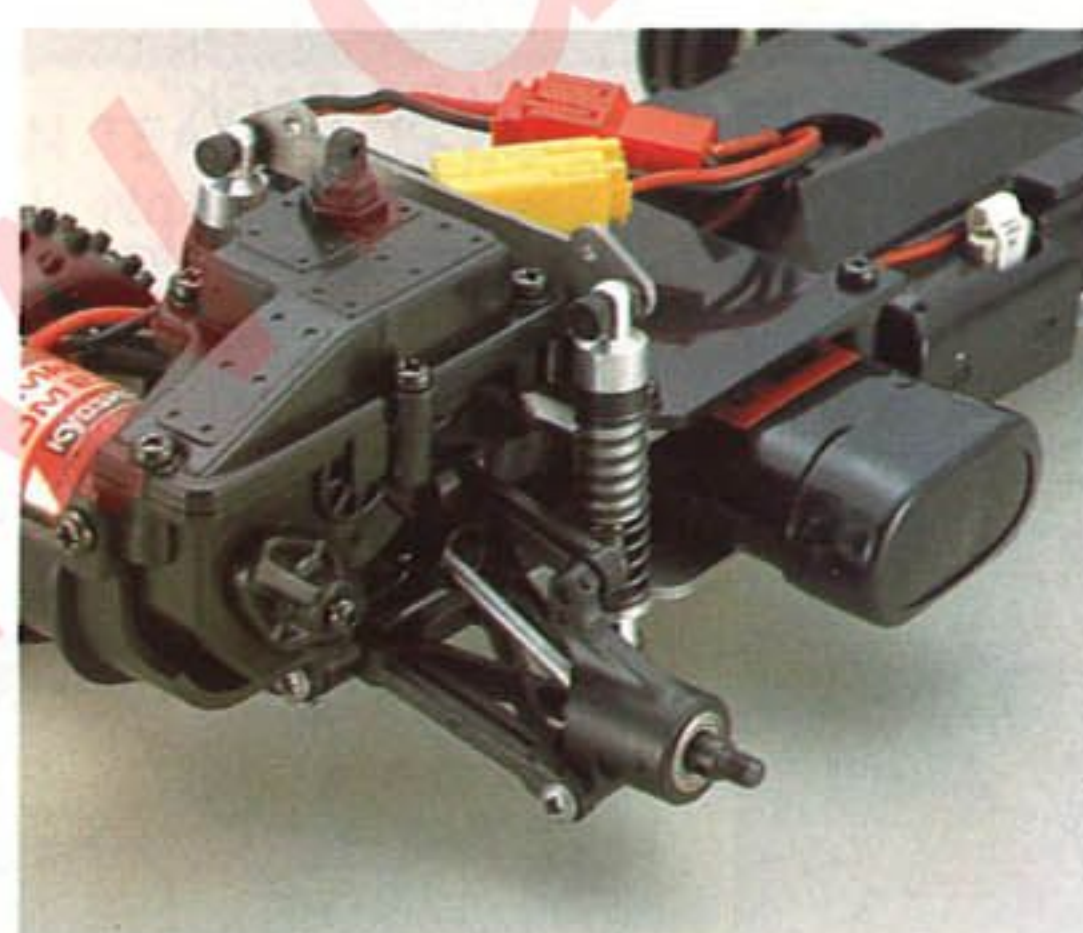
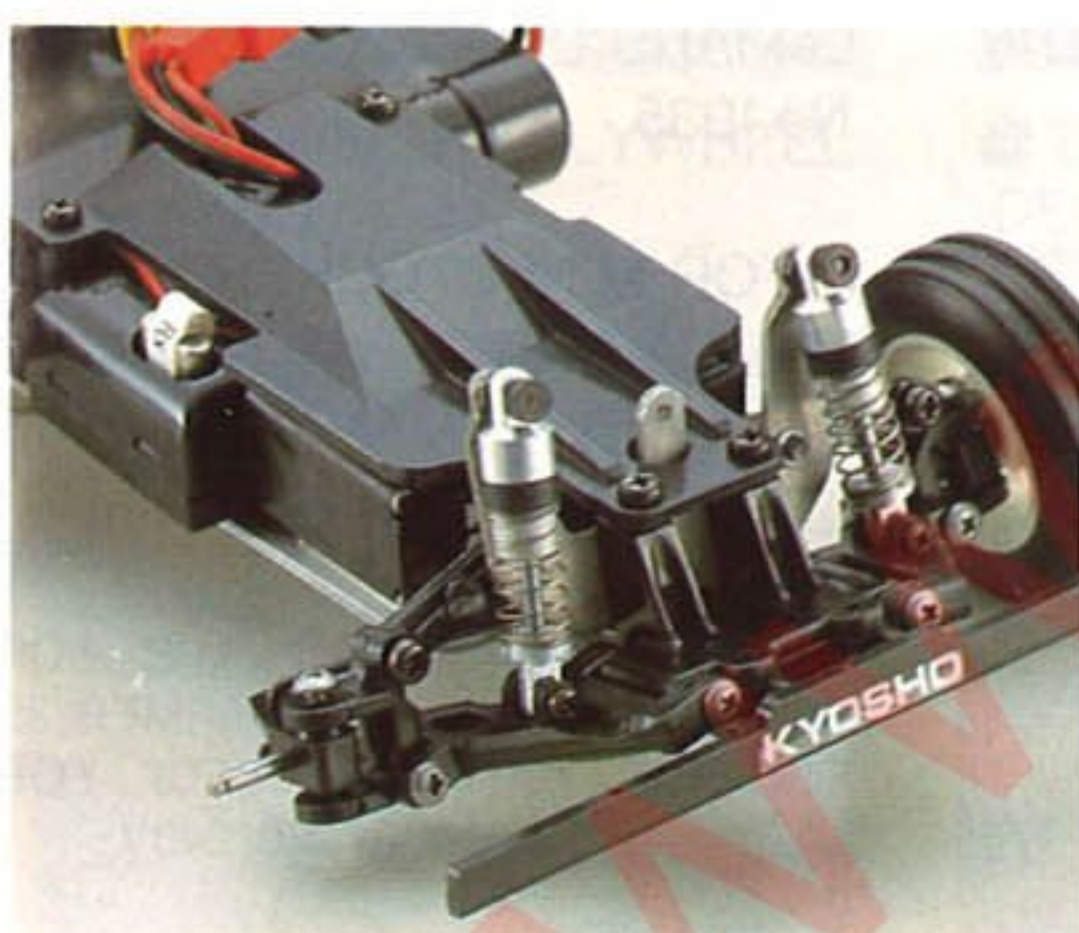
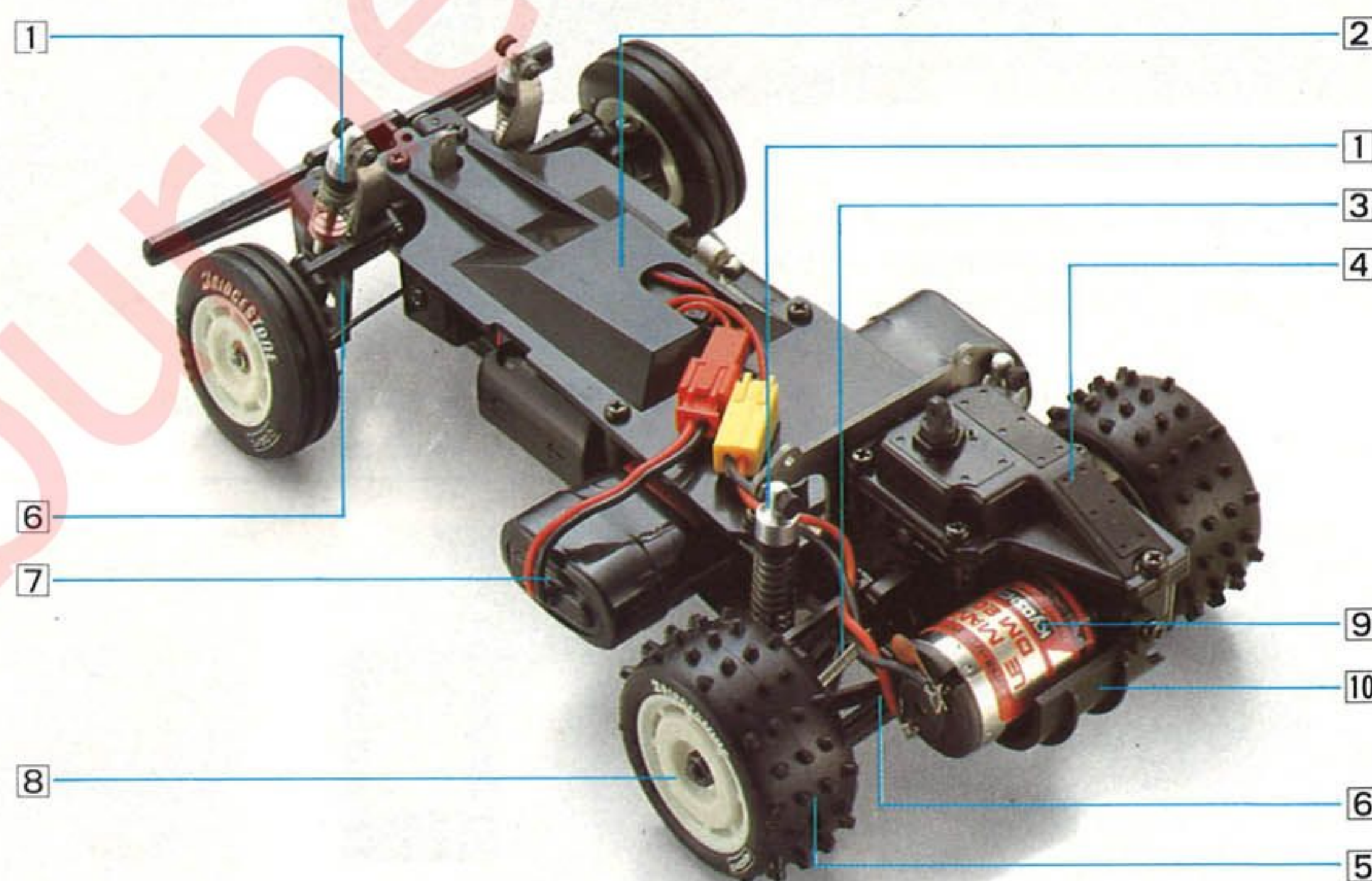

WISHBONE/PARALLEL ARM INDEPENDENT SUSPENSION FRONT/REAR FOR TOP ROADHOLDING. ALUMINUM-BODY FRICTION-TYPE SHOCK ABSORBERS ON ALL WHEELS. ALUMINUM HALF-SHAFTS.

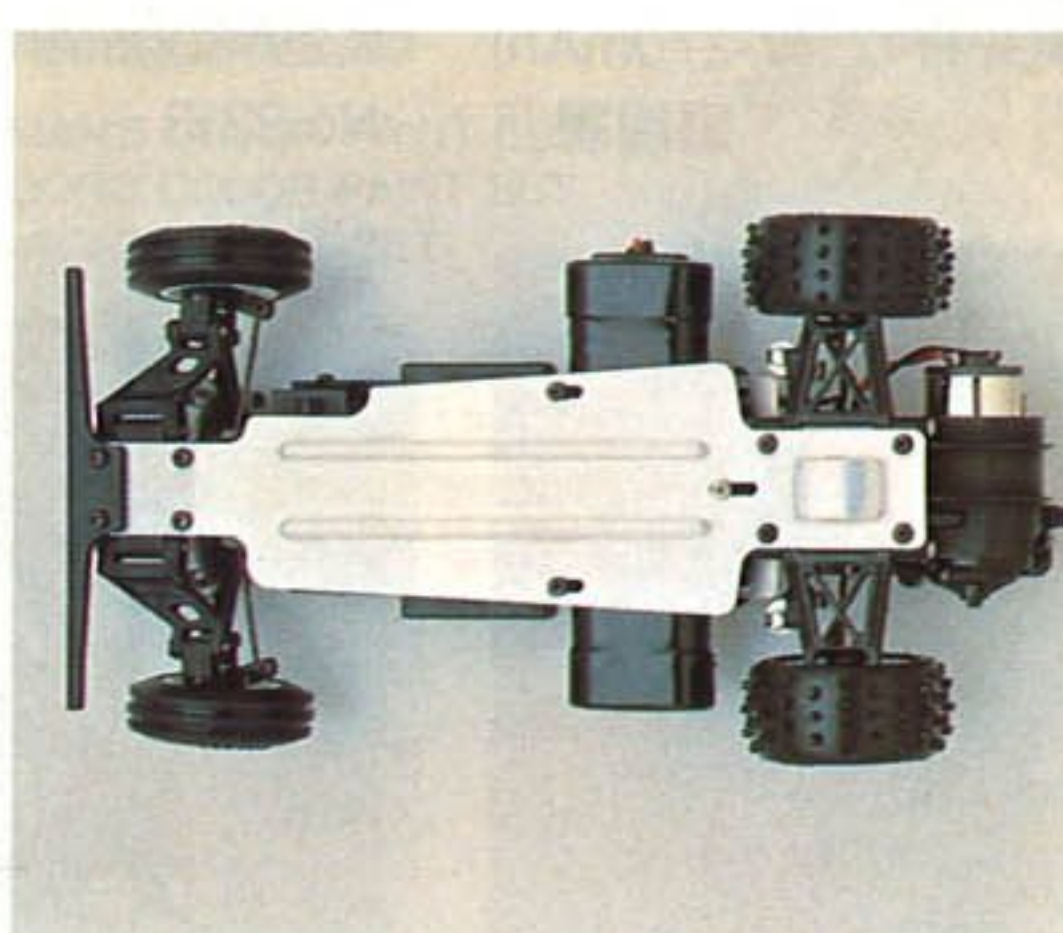

STRONG, LIGHT ABS RADIO PLATE. RIGID ALUMINUM CHASSIS PROTECTS RADIO EQUIPMENT, BATTERY.



HIGH-POWER 7.2V-270mAh NiCd BATTERY INCLUDED, WITH CHARGER.

Trots det lilla formatet är mini-buggy bilarna utrustade med avancerade chassien där varje hjul är separat upphängt osv.

Lämpliga ack-paket och laddare finner Du på nästa sida.

RACEWAY KIT / OPTION PARTS



RACEWAY KIT No.3190

För klubbar och liknande finns en komplett bansargsats att köpa. Den innehåller material för att bygga en bana på måtten 5 x 8 meter som bilden visar. Lämpligt underlag är nålfiltsmatta eller liknande.



- ① STARTING LINE BANNER BOARD
- ② FENCE SECTIONS;
1200mm/10pc
900mm/20pc
600mm/10pc
- ③ CHECKERED FLAGS/2pc
- ④ KYOSHO FLAGS;
RED/10pc
WHITE/10pc
- ⑤ SUPPORT POLES;
LONG/2pc
SHORT/50pc
- ⑥ JUMP/1pc
- ⑦ START LIGHT (NOT INCLUDED)
No.3199

- 1 Startramp
- 2 Sargdelar (10 + 20 + 10)
- 3 Målflagga
- 4 Vimplar
- 5 Sargstolpar (50)
- 6 Hopp av plywood
- 7 Elektrisk starterton säljs separat!



7.2V-270mAh NiCd BATTERY
No.2312



AC CHARGER (7.2V-270mAh)
No.2322



7.2V-600mAh NiCd BATTERY-
No.2313



7.2V-270mAh NiCd BATTERY
"SQUARE PACK"
No.2315

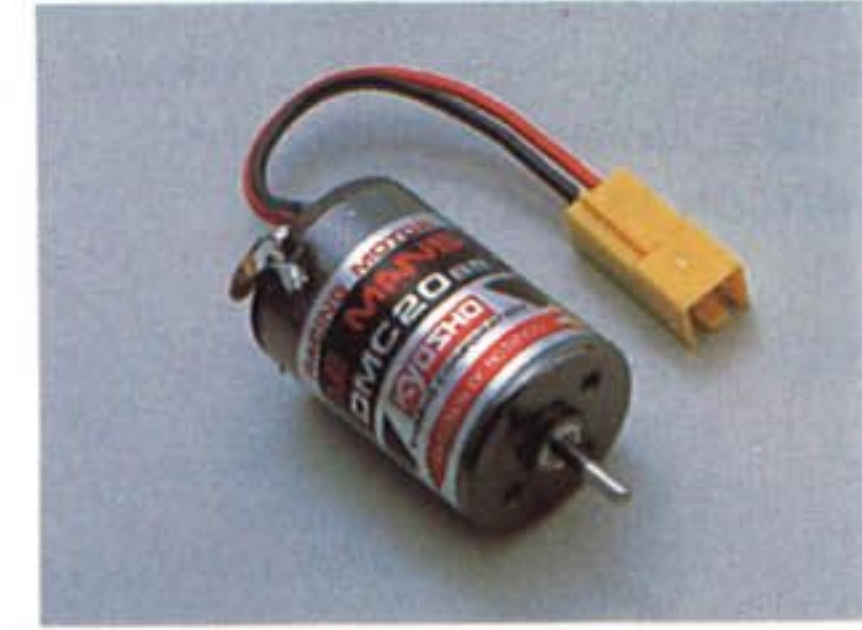

LeMANS DMC 20BB MOTOR
No.1935



DC QUICK CHARGER
(7.2V-270mAh)
No.2332



AC QUICK CHARGER
(7.2V-270mAh)
No.2342



DC QUICK CHARGER
(7.2V-600mAh)
No.2325



AC QUICK CHARGER
(7.2V-600mAh)
No.2345

- FOR MINI STOCKERS
- BAJA BAGS
- GRAND PRIX MOTORCYCLES
- F-1 RACING CARS

NOTE: AC CHARGERS ARE FOR 100V ONLY. A TRANSFORMER IS REQUIRED (NOT INCLUDED) FOR USE WITH 120V OR 220/240V

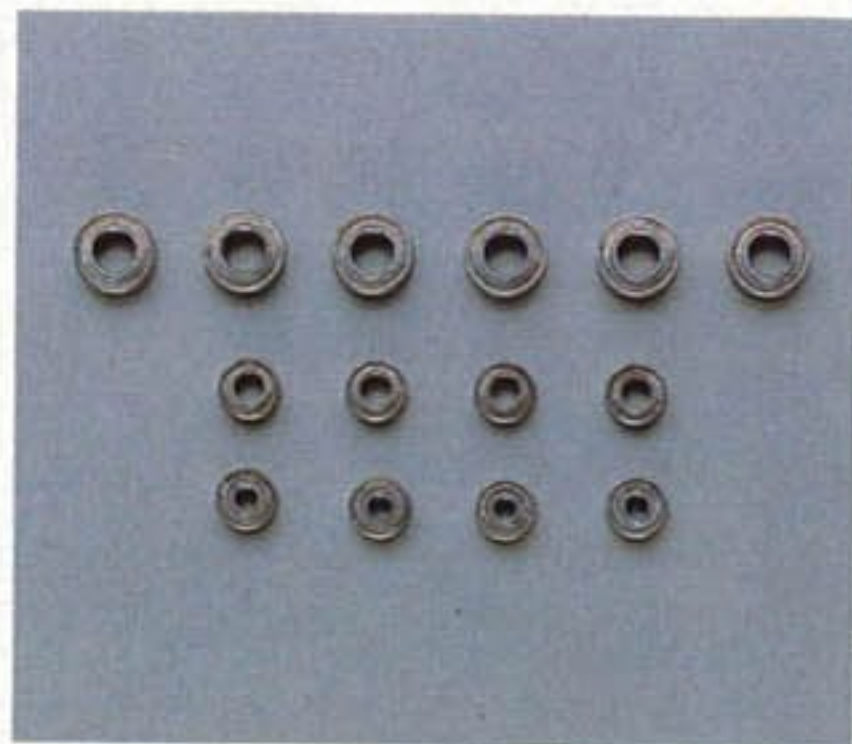

**BALL BEARING SET
(FOR BAJA BAGS)**
No.1975



ALUMINUM WHEEL SET
No.DEW-1



SPONGE TIRE SET
No.DEW-2



SPECIAL SHOCK MOUNT
No.DEW-3



SOFT SPRING SET
No.DEW-4



BALL BEARING SET
No.1977



FRONT OIL-FILLED SHOCK
No.GPW-1



REAR OIL-FILLED SHOCK
No.GPW-2



REINFORCED PINION SET
No.GPW-3



No.GPW-4 '87 HRC WORKS DECALS
No.GPW-10 '88 YAMAHA WORKS DECALS



LIGHTWEIGHT FLYWHEEL
No.GPW-7



**'88 AN TEAM BLUE FOX
DECALS** No.GPW-8



No.GPW-5 ROTHMAN'S COLOR PAINT SET
No.GPW-6 MARLBORO COLOR PAINT SET
No.GPW-9 PEPSI COLOR PAINT SET



PULSAR PRO 2000

■ RS-V NO.2557 (FOR MINI SIZE CAR) ■ ■ RS-V NO.2546 (FOR MINI SIZE CAR) ■ ■
■ RS-M NO.2558 (FOR MOTOR CYCLE) ■ ■ RS-M NO.2547 (FOR MOTOR CYCLE) ■



IMPULSE II

■ RS-V NO.2557 (FOR MINI SIZE CAR) ■ ■ RS-V NO.2546 (FOR MINI SIZE CAR) ■ ■
■ RS-M NO.2558 (FOR MOTOR CYCLE) ■ ■ RS-M NO.2547 (FOR MOTOR CYCLE) ■



BALL BEARING SET
No.1978

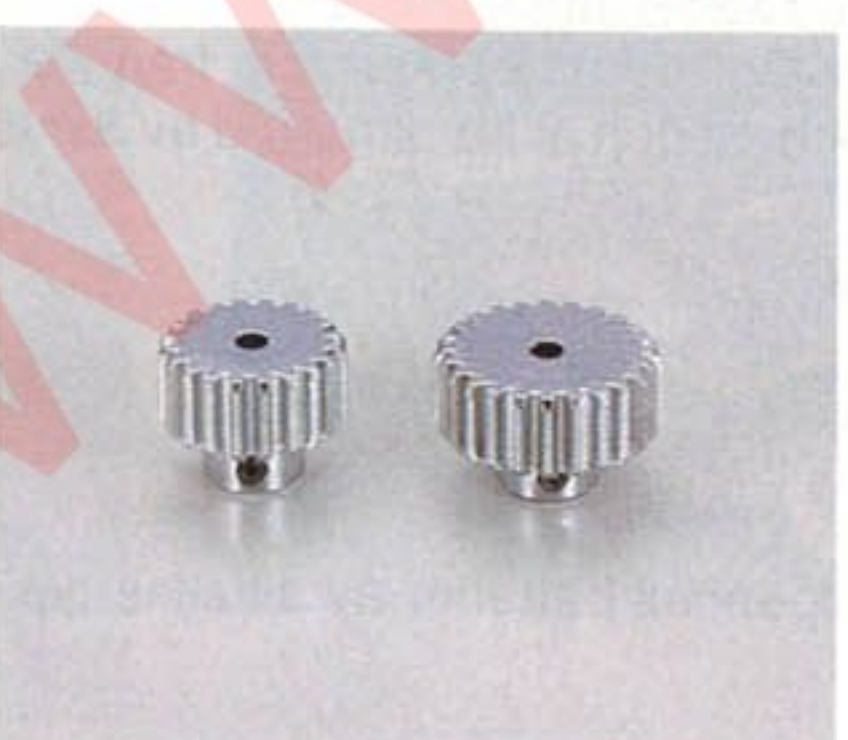

REINFORCED PINION SET
No.FRW-1



No.FRW-2 CAMEL COLOR PAINT SET
No.FRW-3 MARLBORO COLOR PAINT SET
No.FRW-4 WILLIAMS COLOR PAINT SET



RECEIVER/SERVO UNIT

■ RS-V NO.2566 (FOR MINI SIZE CAR) ■ ■ RS-V NO.2567 (FOR MOTOR CYCLE) ■

**LÄS MER OM RADIO PÅ
SIDAN 139 & 140.**



COMPLETE AND READY TO RUN!

JUST TAKE THE "FA" MACHINE OUT OF THE BOX, PUT BATTERIES INTO THE BUGGY AND TRANSMITTER (INCLUDED IN SET), AND THE FUN BEGINS! MODEL IS COMPLETELY ASSEMBLED AND ADJUSTED AT THE FACTORY. TRANSMITTER IS FULLY PROPORTIONAL: MOVE A STICK AND THE DIRECTION OR SPEED CHANGES SMOOTHLY. GOOD HANDLING: IT'S FROM THE DESIGNERS OF THE FAMOUS OPTIMA AND ULTIMA. MANY OPTIONAL PARTS AVAILABLE FOR HIGHER PERFORMANCE. RECHARGEABLE BATTERIES AND CHARGER AVAILABLE FOR LONG-TERM ECONOMY.

REQUIRED FOR OPERATION (NOT INCLUDED)

TRANSMITTER: 1×9V(006P) BATTERY (ALKALINE TYPE RECOMMENDED)
RECEIVER: 8 PENLIGHT (AA) CELLS (ALKALINE OR NICKEL CADMIUM TYPE RECOMMENDED)

Technical Data

①Length/315mm (12.4") ②Width/190mm (7.5") ③Height/130mm (5.1") ④Wheelbase/206mm (8.1") ⑤Front track/153mm (6.0") ⑥Rear track/150mm (5.9") ⑦Weight/850g (1.9 lb) ⑧Tires/(F)φ64×27mm; (R)φ64×31mm ⑨Motor (included)/LeMans X5 ⑩Batteries (not included)/Pencells (AA-size)×4; 9V (006P-type)×1 ⑪Radio control set (included)/Wheel-type two-channel transmitter; receiver; steering servo; electronic speed controller

OPTIMA BUGGY FÖR UNGA KYOSHO ENTUSIASTER

Det här är en buggy för de allra yngsta Kyosho entusiasterna. Den är färdigbyggd, levereras komplett med radio och hör alltså hemma bland vad vi brukar kalla lekradiobilar. Det betyder att radion inte har lika lång räckvidd som en "riktig" radio men naturligtvis också att priset är lägre! Att den kommer från Kyosho är ju också en garanti för att den fungerar perfekt och att den är konstruerad av det företag som också bygger världsmästar buggy!

Den drivs av 8 st pencell batterier av alkaline typ eller av lika många uppladdningsbara nicad penceller.

FA SERIES (Factory Assembly Series)
ELECTRIC POWERED RACING BUGGIES
COMPLETE WITH RADIO CONTROL SYSTEM

TURBO OPTIMA 14X No. 9051
SKY BOMBER 14X No. 9054

1:14 SCALE 



- COMPLETE READY-TO-RUN SET! FACTORY ASSEMBLED AND ADJUSTED! NO BUILDING REQUIRED!
- TRANSMITTER, RECEIVER, STEERING SERVO AND ELECTRONIC SPEED CONTROLLER INCLUDED!
- PROPORTIONAL SPEED CONTROL FOR SMOOTH DRIVING!
- CRYSTALS CAN BE CHANGED (OPTIONAL) TO OPERATE ON ANOTHER FREQUENCY!
- POWERFUL LeMANS X5 MOTOR (INCLUDED)! HOP-UP VERSION AVAILABLE (OPTIONAL).
- FINAL GEAR RATIO SELECTABLE BY LEVER (TWO RATIOS).
- LOW-PROFILE PIN-TYPE RUBBER TIRES FOR TOP HANDLING AND CORNERING!
- USES READILY-AVAILABLE PENCELL-SIZE BATTERIES (NOT INCLUDED). RECHARGEABLE NICKEL CADMIUM BATTERIES AVAILABLE AS OPTION.
- * RECHARGING JACK

Färdigbyggd och helt komplett med sändare, mottagare och ett elektroniskt fartreglage. Ladda med fräska batterier och ge Dig iväg på en första provtur! Varje hjul separat upphängt med friktionsdämpare och långa bärramar för bästa väghållning! Snabb och stark LeMans X5 motor står för acceleration och bra toppfart!



■ OIL-FILLED SHOCK SET
No.FCW-1



■ BEARING SET
No.FCW-2



■ SQUARE BLOCK TIRE
(FRONT × 2) No.FCW-3



■ SQUARE BLOCK TIRE
(REAR × 2) No.FCW-4

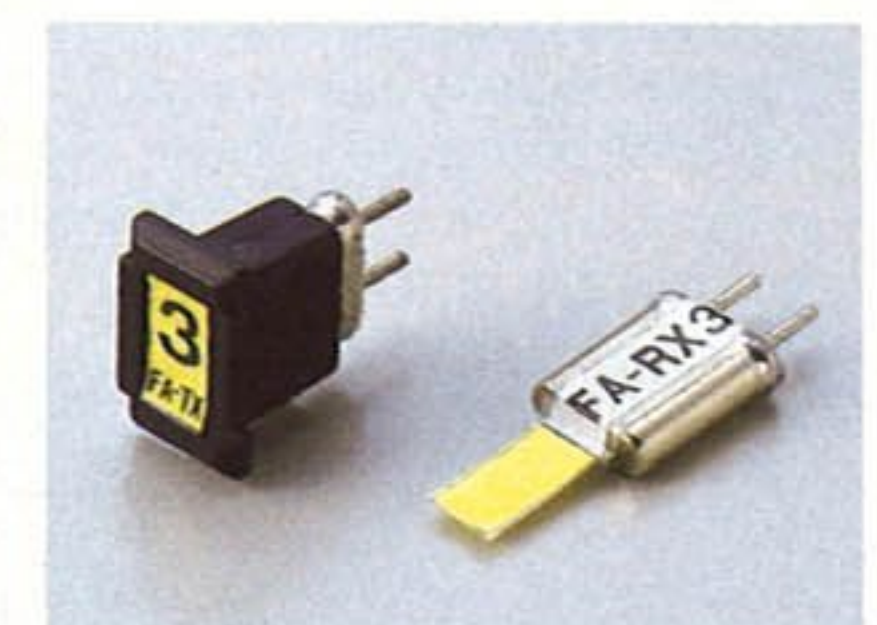

■ BAND 1 No.9084-A
BAND 2 No.9084-B
BAND 3 No.9084-C
BAND 4 No.9084-D
BAND 5 No.9084-E
BAND 6 No.9084-F



■ TURBO ULTIMA BODY SET
(W/DECAL) No.FCW-5



■ SHUTTLE JET 14X BODY SET (1)
(W/DECAL) No.FCW-6 1/14



■ NS-3 AC CHARGER No.9082

■ SUPER NiCd BATTERY &
AC CHARGER SET No.9081

■ SUPER NiCd BATTERY
No.9083

TILL 14X SERIEN FINNS MÅNGA EXTRA TILLBEHÖR FÖR ATT GÖRA DEN ÄNNU VASSARE.

CAR CRUSHER

ELECTRIC POWERED OFF-ROAD RECREATIONAL VEHICLES

■ DOUBLE DARE 4WDS ■ HI-RIDER CORVETTE
 ■ BIG BRUTE ■ NITRO BRUTE

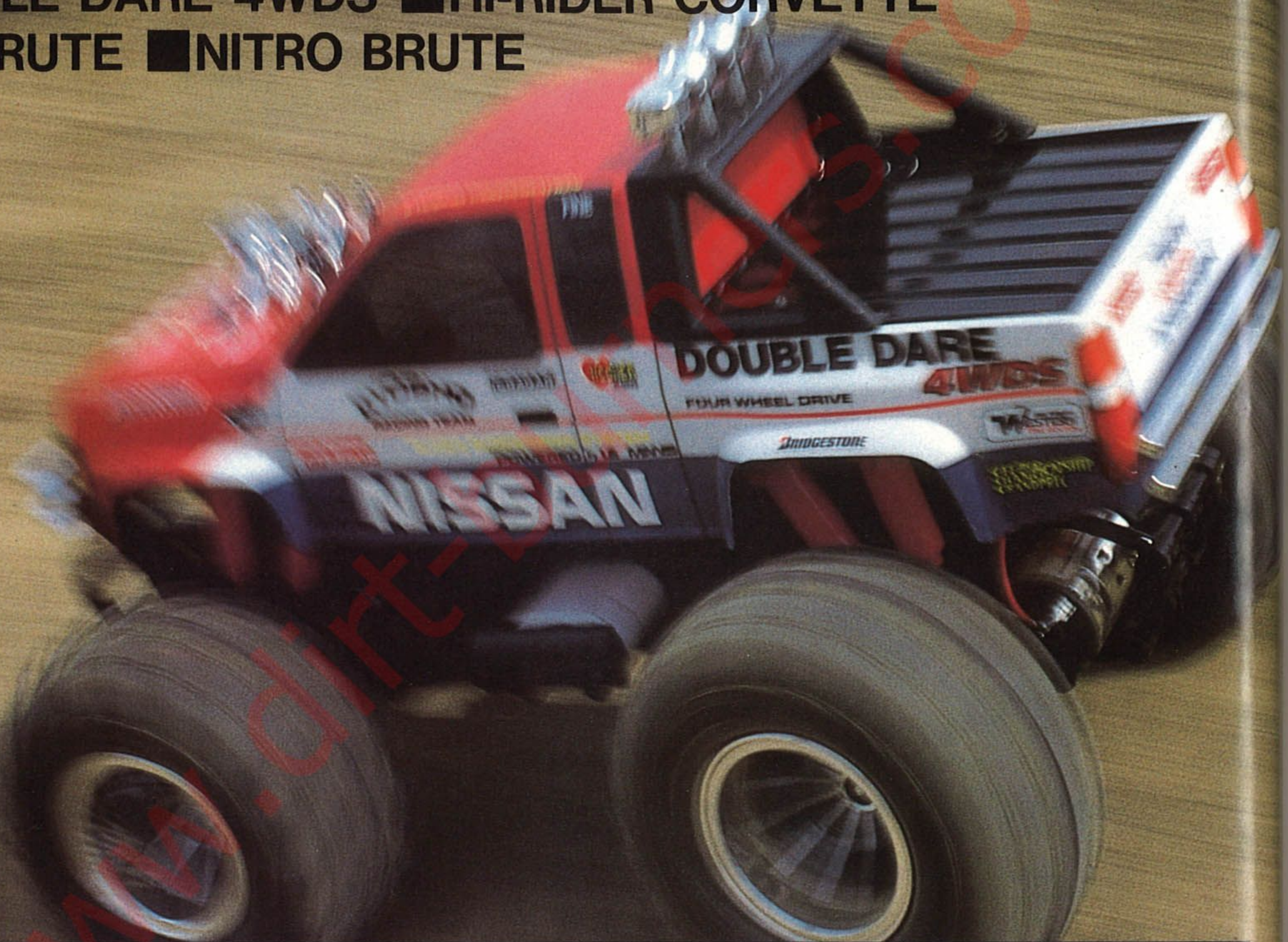

	Name	Length	Height	Weight	Suspension	Shock Absorbers	Motor/Engine	Battery	Potential for Hop-up*
4WDS	DOUBLE DARE 4WDS	440mm	295mm	2800g	(F) WS; (R) WS	8 Friction Type	2 LeMans Stock 05	7.2V-1200mAh	△
2WD	HI-RIDER CORVETTE	465mm	265mm	2650g	(F) WS; (R) WS	8 Friction Type	LeMans Stock 05	7.2V-1200mAh	△
	BIG BRUTE	460mm	250mm	2650mm	(F) WS; (R) WS	4 Friction Type	LeMans Stock 05	7.2V-1200mAh	△
2WD	NITRO BRUTE	470mm	250mm	2600g	(F) WS; (R) WS	4 Friction Type	ENYA Quicky 09 BB		△

(F)=FRONT, (R)=REAR, WS=DOUBLE WISHBONE or WISHBONE/PARALLEL ARM, TS=TRAILING ARM, SS=SLIDING PILLAR *◎High, ○Moderate, △Low

CAR CRUSHER DOUBLE DARE 4WDS

ELECTRIC POWERED OFF-ROAD RECREATIONAL VEHICLE

1:10 SCALE

No. 3106



DOUBLE DARE DOUBLES YOUR CAR CRUSHING FUN!

- 1 GIANT, SPECIAL PATTERN TIRE.
- 2 STRONG, DUST-SHIELDED TUB CHASSIS. LIGHT ABS RESIN.
- 3 HIGH-QUALITY HEAVY DUTY ROTARY SPEED CONTROLLER (INCLUDED).
- 4 GEARBOX AND DIFFERENTIAL (FRONT/REAR).
- 5 POWERFUL LeMANS STOCK 05 MOTOR (INCLUDED).
- 6 SHOCK ABSORBER (WITH INTERNAL SPRING).
- 7 REAR MOTOR GUARD.
- 8 REALISTIC CHROME-FINISH ENGINE REPLICA.
- 9 PROTECTIVE NYLON FRONT BUMPER.
- 10 POWERFUL LeMANS STOCK 05R MOTOR (INCLUDED).
- 11 7.2V "STICK" TYPE NiCd BATTERY (1200mAh OR LARGER; NOT INCLUDED).
- 12 QUICK CHANGE BATTERY HOLDER.
- 13 STRONG, LIGHT CHROME-FINISH NYLON WHEELS.
- 14 COVERED CHASSIS PROTECTS RADIO EQUIPMENT.

STYR OCH DRIVER PÅ FYRA HJUL

På en DoubleDare är det mesta dubbelt! Dubbla stötdämpare runt om. Dubbel drivning från dubbla motorer via dubbla växelhjul med dubbla differentier. Till och med styrningen är dubbel - den styr på alla fyra hjulen! Den kraftiga chassiebalken fungerar också som skydd för radioinstallationen. En supertuff kaross och många kromade detaljer gör DoubleDare till en av de häftigaste i sin klass!

Titta själv på alla detaljerna på bilderna. En äkta Kyosho storhjulning!

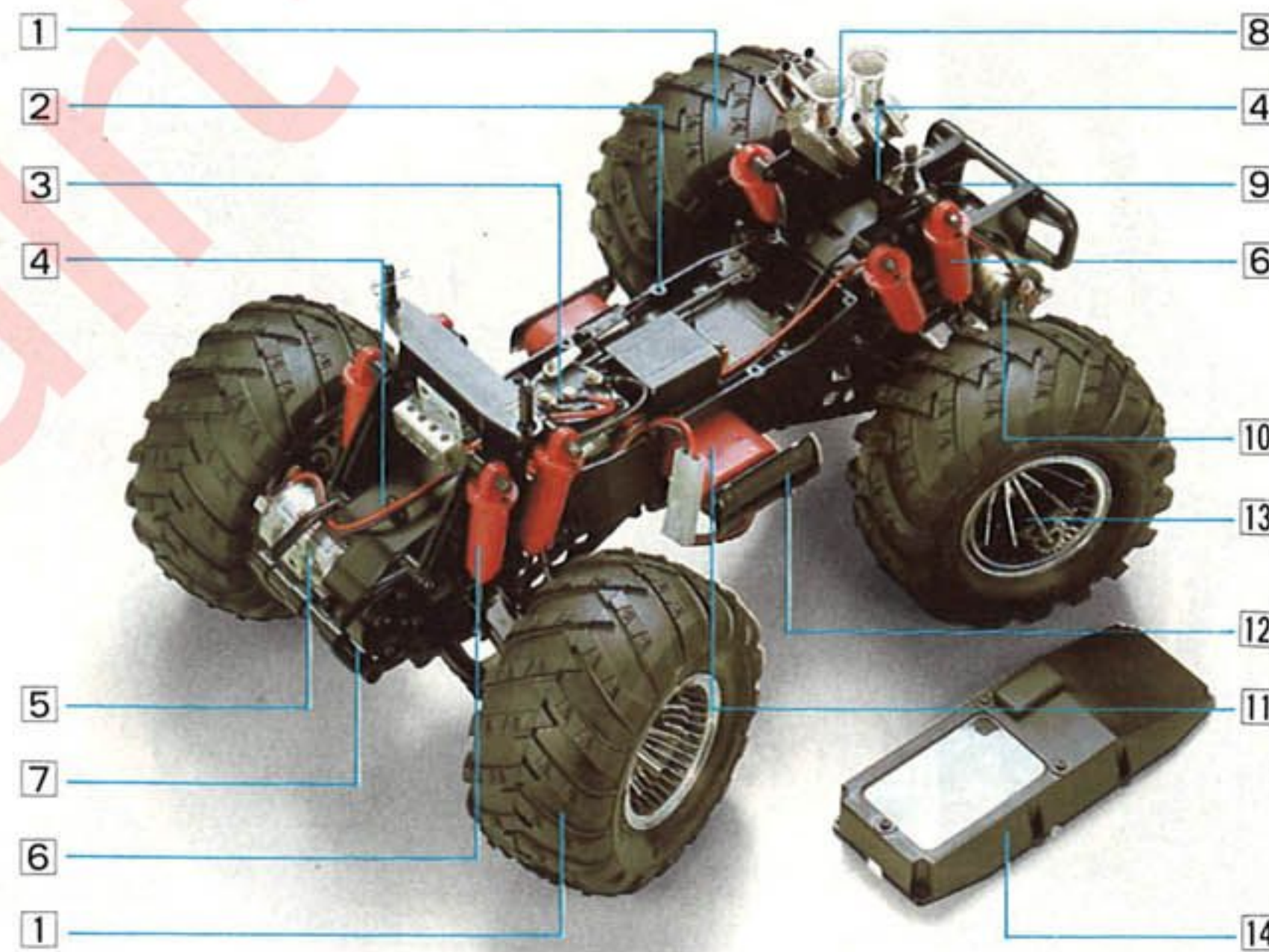
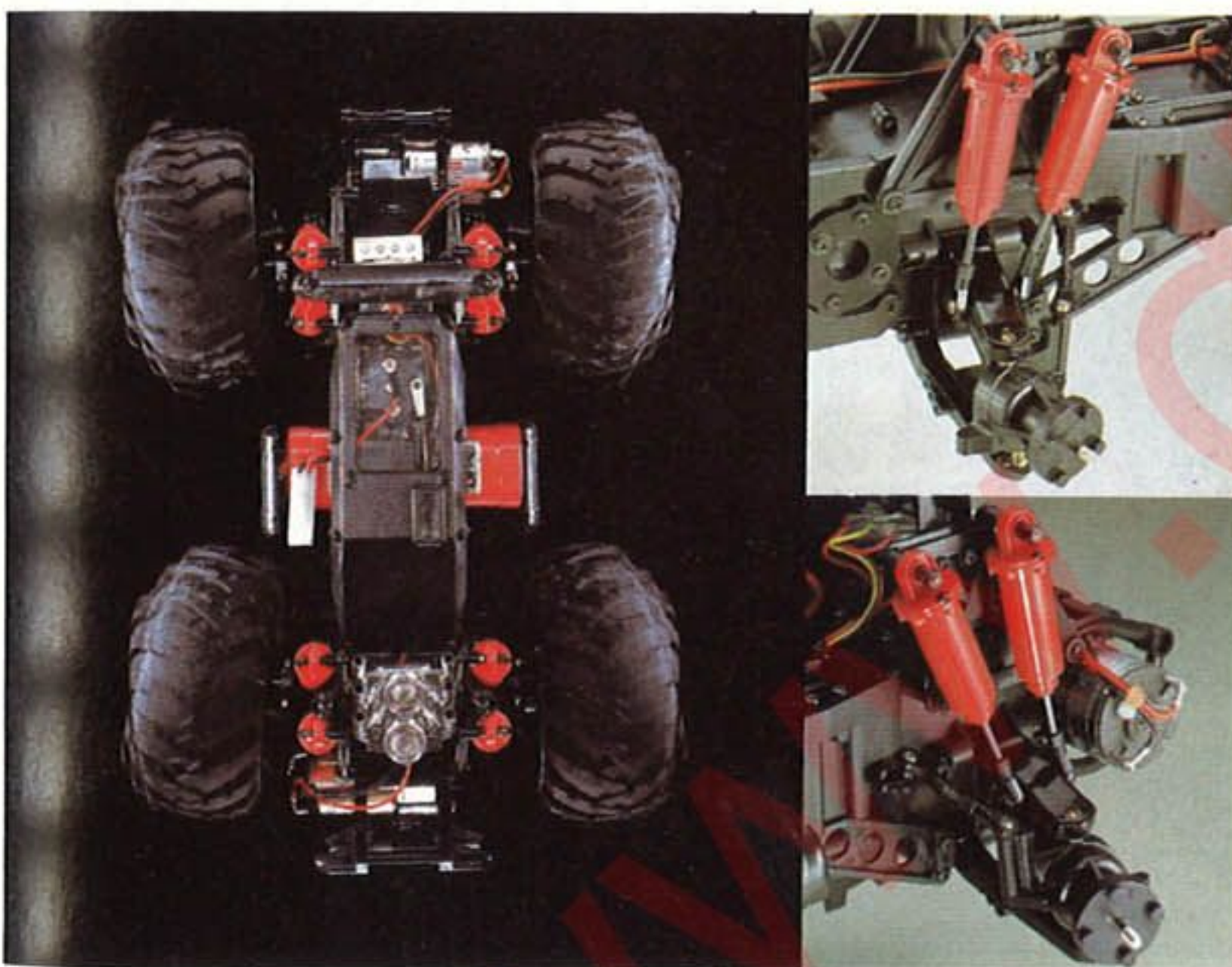

REQUIRED FOR OPERATION / RECOMMENDED FOR BEST APPEARANCE (NOT INCLUDED)

●RADIO CONTROL SET (TWO-CHANNEL) ●BATTERY: 7.2V-1200mAh OR 7.2V-1700mAh NiCd ●BATTERY CHARGER ●POLYCA COLOR PAINTS ●MICRON LINE STRIPING TAPE

Technical Data

1 Length/440mm (17.3") 2 Width/310mm (12.2") 3 Height/295mm (11.6") 4 Wheelbase/265mm (10.4") 5 Ground clearance/70mm (2.75") 6 Front track/237mm (9.3") 7 Rear track/237mm (9.3") 8 Weight (track-ready)/2800g (6 1b 3oz) 9 Tires (F/R) / φ146 × 73mm 10 Motors (included) / LeMans stock 05 (×2) 11 Battery (not included) / 7.2V-1200/1700mAh NiCd ("stick" type) 12 Radio control set (not included) / Two-channel

Technische Daten

1 Länge 2 Breite 3 Höhe 4 Radstand 5 Bodenfreiheit 6 Spur, vorne 7 Spur, hinten 8 Gesamtgewicht 9 Räder, vorne / Räder, hinten 10 Motor 11 Akku 12 Fernsteuerung

DET HÄR BEHÖVS FÖRUTOM BYGGSATSEN

En tvåkanals radio, ett 7.2V/1200mAh ackpaket samt laddare.

CAR CRUSHER HI-RIDER CORVETTE

ELECTRIC POWERED OFF-ROAD RECREATIONAL VEHICLE

1:10 SCALE
No. 3107



DO YOUR CAR CRUSHING IN STYLE

- ① HUGЕ (146×73mm, 5.75×2.87") HIGH TRAC-TION RUBBER TIRES.
- ② DEPENDABLE AND EFFECTIVE SHOCK ABSOR-BERS (2 PER, WHEEL) WITH ADJUSTABLE SPRINGING.
- ③ STRONG, RUGGED ABS TUB TYPE CHASSIS.
- ④ HEAVY DUTY ROTARY SPEED CONTROLLER WITH 3 FORWARD SPEEDS, NEUTRAL, AND 1 REVERSE SPEED.
- ⑤ SEALED GEARBOX/DIFFERENTIAL.
- ⑥ PROTECTIVE REAR GUARD.
- ⑦ POWERFUL LeMANS STOCK 05 MOTOR (IN-CLUDED).
- ⑧ STRONG, PROTECTIVE FRONT BUMPER.
- ⑨ DOUBLE-WISHBONE FRONT SUSPENSION WITH LONG TRAVEL.
- ⑩ QUICK-CHANGE BATTERY COMPARTMENT.
- ⑪ DOUBLE-WISHBONE REAR SUSPENSION WITH LONG TRAVEL STRONG ABS PARTS.
- ⑫ FULLY ENCLOSED, PROTECTIVE COMPARTMENT FOR RADIO EQUIPMENT AND SPEED CONTROL-LER.
- ⑬ STRONG, CHROME-FINISH NYLON WHEELS.

HÄFTIGASTE STORHJULINGEN

HiRider är en tvåhjuldriven bror till Dou-bleDare. Det mesta i chassiekonstruktion-
en är hämtat därifrån. Till och med det nya
robusta "rotary" fartreglaget ingår. Skillna-
den är att HiRider är bakhjulsdriven och
styr med enbart framhjulen. Vilken som är
tuffast? Ja, det får Du avgöra själv! HiRi-
dern blir ju tack vare att den inte är fyrhjul-
driven lite billigare i inköp. Se bara till att det
blir en äkta Kyosho när Du väljer storhju-
ling!



REQUIRED FOR OPERATION / RECOMMENDED FOR BEST APPEARANCE (NOT INCLUDED)

● RADIO CONTROL SET (TWO-CHANNEL) ● BATTERY: 7.2V-1200mAh OR 7.2V-1700mAh NiCd ● BATTERY CHARGER ● POLYCA COLOR PAINTS ● MICRON LINE STRIPING TAPE

Technical Data

① Length/465mm (18.3") ② Width/300mm (11.8") ③ Height/265mm (10.4") ④ Wheelbase/283mm (11.1") ⑤ Ground clearance/70mm (2.8") ⑥ Front track/237mm (9.3") ⑦ Rear track/237mm (9.3") ⑧ Weight (track-ready)/2650g (5 lb 13oz) ⑨ Tires (F/R)/φ146×73mm ⑩ Motor (included)/LeMans stock 05 ⑪ Battery (not included)/7.2V-1200/1700mAh NiCd ("stick" type) ⑫ Radio control set (not included)/Two-channel

DET HÄR BEHÖVS FÖRUTOM BYGGSATSEN

En tvåkanals radio, ett 7.2V/1200 mAh ackpaket och en laddare.

CAR CRUSHER BIG BRUTE

ELECTRIC POWERED OFF-ROAD RECREATIONAL VEHICLE
No. 3105

CAR CRUSHER NITRO BRUTE

10 ENGINE POWERED OFF-ROAD RECREATIONAL VEHICLE
No. 3110G

1:10 SCALE



- ① HUGE 136×80mm (5.4×3.2 INCH) HIGH-GRIP RUBBER TIRES.
- ② STRONG, PROTECTIVE FRONT BUMPER.
- ③ DEPENDABLE, EFFECTIVE FRICTION SHOCK ABSORBERS.
- ④ QUICK-CHANGE BATTERY COMPARTMENT.
- ⑤ STRONG, RUGGED ABS CHASSIS.
- ⑥ LONG-LIFE SPEED CONTROLLER.
3 SPEEDS FORWARD, 1 REVERS.
- ⑦ ENCLOSED, PROTECTIVE RADIO COMPARTMENT.
- ⑧ DOUBLE WISHBONE FRONT SUSPENSION. LONG WHEEL TRAVEL. STRONG ABS PARTS.
- ⑨ STRONG, LIGHT ABS WHEELS.
- ⑩ POWERFUL LeMANS "STOCK 05" MOTOR.
- ⑪ SEALED GEARBOX/DIFFERENTIAL FOR PROTECTION FROM DUST, WATER, STRONG ABS GEARS, HARD POLYESTER RESIN GEARS.
- ⑫ REAR GUARD PROTECTS MOTOR IN "SHUNTS".
- ⑬ DOUBLE-WISHBONE REAR SUSPENSION. LONG WHEEL TRAVEL.

VÄLKÄNDA STORHJULINGAR

BigBrute eller NitroBrute? Mycket är samma i båda modellerna med den viktiga skillnaden att den senare drivs av förbränningsmotor och därför i första hand är avsedd för Dig som är lite äldre. Det gör den förstås lite vassare och snabbare men också mer ljudlig. Grundkonstruktionen i det väl fungerande chassiet med separat upphängda hjul runt om är samma som i DoubleDare & HiRider.



■ NITRO BRUTE

NITRO BRUTE IS DESIGNED FOR EVEN MORE EXCITING PERFORMANCE WITH .10 ENGINE. (ENGINE NOT INCLUDED. MUFFLER INCLUDED.)

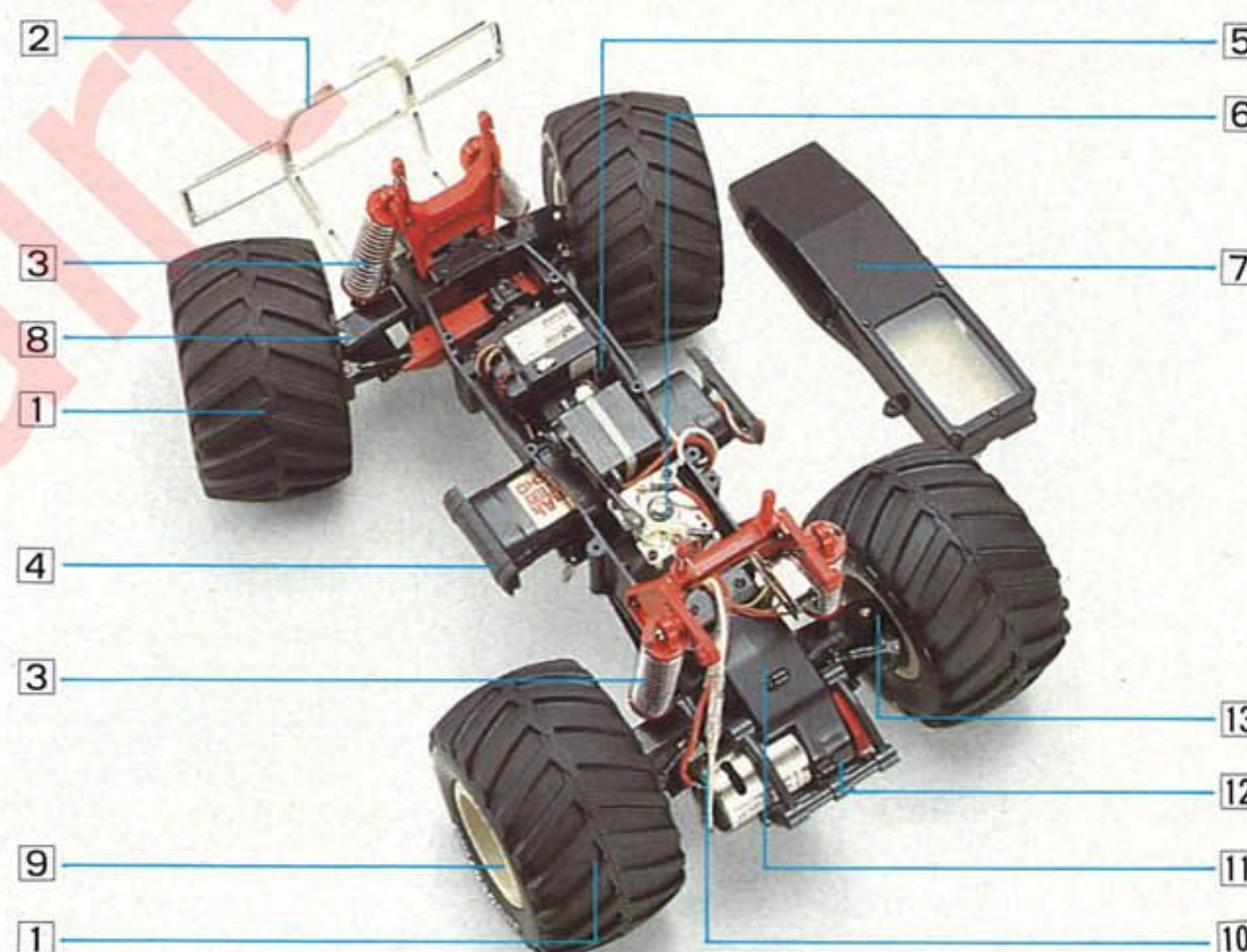

DET HÄR BEHÖVS FÖRUTOM BYGGSETSEN

BigBrute behöver ett 7.2V/1200mAh ack-paket och en laddare medan NitroBrute behöver en passande 2cc förbränningsmotor. Båda behöver förstås en två kanals radio.

REQUIRED FOR OPERATION / <> : NITRO BRUTE

- RADIO CONTROL SET (2-CHANNEL) ● BATTERY (7.2V-1200mAh NiCd) ● BATTERY CHARGER
- POLYCA COLOR PAINTS ● MICRONLINE STRIPPING TAPE <●. 10 ENGINE>

Technical Data / <> : NITRO BRUTE

① Length/460mm(18.1in)<470mm> ② Width/310mm(12.2in) ③ Height/250mm(9.8in) ④ Wheelbase/283mm(11.5in)<290mm> ⑤ Ground Clearance/70mm(2.8in) ⑥ Front Track/220mm(8.7in) ⑦ Rear Track/215mm(8.5in) ⑧ Tires/(F)136φ×80mm (5.4×3.2in);(R)136φ×80mm(5.4×3.2in) ⑨ Total Weight/2650g(51b 13oz) ⑩ Gear Ratio/16.1:1<29:1> ⑪ Motor/Le Mans Stock 05 (Included) <.09-.11Class Engine> ⑫ Battery/7.2V-1200mAh(Not included) ⑬ Radio/2-Channel(Not included)

2WD OFF ROAD RACERS

■ RAIDER 2WD ■ MAXXUM FF ■ ULTIMA
■ TURBO ULTIMA ■ ULTIMA PRO

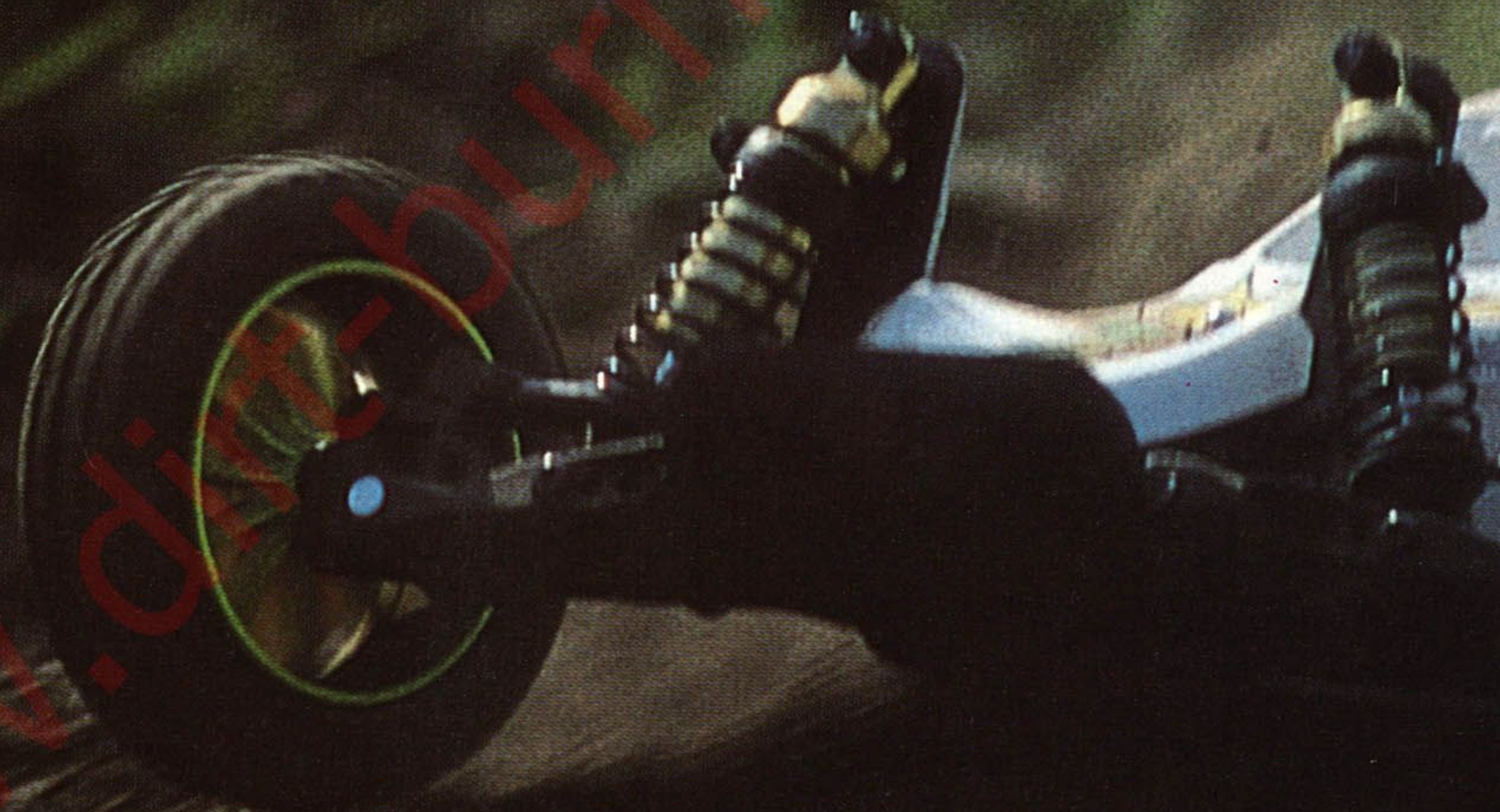

ELECTRIC POWERED RACING BUGGIES



	Name	Length	Height	Weight	Suspension	Shock Absorbers	Motor	Battery	Potential For Hop-up*
2 W D	RAIDER 2WD	390mm	140mm	1450g	(F) WS; (R) WS	4 Friction Type	LeMans Stock 05	7.2V-1200mAh	○
	MAXXUM FF	350mm	130mm	1500g	(F) WS; (R) WS	4 Oil-Filled Type	LeMans 240ST	7.2V-1200mAh	○
	ULTIMA	360mm	130mm	1500g	(F) WS; (R) WS	4 Oil-Filled Type	RS-540S	7.2V-1200mAh	◎
	TURBO ULTIMA	360mm	130mm	1500g	(F) WS; (R) WS	4 Oil-Filled Type	LeMans 240ST	7.2V-1200mAh	◎
	ULTIMA PRO	360mm	130mm	1500g	(F) WS; (R) WS	4 Oil-Filled Type	—	7.2V-1200mAh	◎

(F)=FRONT, (R)=REAR, WS=DOUBLE WISHBONE or WISHBONE/PARALLEL ARM, TS=TRAILING ARM, SS=SLIDING PILLAR * ◎High, ○Moderate, △Low



FAST, RELIABLE, AND EASY TO RUN!

RAIDER 2WD, THE IDEAL CHOICE FOR THE NEW DRIVER. FAST PERFORMANCE WITH A MINIMUM OF CONSTRUCTION TIME AND ADJUSTMENT. DURABLE MATERIALS. FOUR-WHEEL INDEPENDENT SUSPENSION FOR GOOD HANDLING ON ANY SURFACE. LIGHT FRICTION-TYPE SHOCK ABSORBERS. POWERFUL LeMANS STOCK 05 MOTOR AND SPEED CONTROLLER (3 FWD/1 REV) INCLUDED. RELIABLE REAR-WHEEL DRIVE WITH GEAR-TYPE DIFFERENTIAL COMBINES WITH HIGH-GRIP TIRES TO PUT MAXIMUM POWER ON THE TRACK.

REQUIRED FOR RUNNING/RECOMMENDED FOR BEST APPEARANCE (NOT INCLUDED)

- TWO-CHANNEL RADIO CONTROL SET ● 7.2V-1200mAh NiCd BATTERY PACK ● CHARGER
- POLYCA COLOR PAINT

Technical Data

①Length/390mm(15.4in) ②Width/250mm(9.8in) ③Height/140mm(5.5in) ④Wheelbase/260mm(10.2in) ⑤Ground Clearance/29mm(1.1in) ⑥Front Track/200mm(7.9in) ⑦Rear Track/210mm(8.3in) ⑧Tires/(F)φ77×23mm;(R)φ82×40mm ⑨Total Weight/1450g(3.2 lb) ⑩Gear Ratio/10.8:1 ⑪Motor/Le Mans Stock 05(Included) ⑫Battery/7.2V-1200mAh(Not included) ⑬Radio/2-Channel(Not included)

LÅT EN RAIDER BLI DIN FÖRSTA RACER

Det här är den perfekta nybörjarmodellen. Tvåhjulsdriften gör den lätt att bygga, lätt att sköta men också lättdriven så att laddningen räcker länge och toppfarten blir hög. Materialet är i stor utsträckning olika sorters konstruktionsplaster för att ge en lättbyggd men ändå stark racer. Priset för den "perfekta nybörjarbuggyn" är dessutom tilltalande lågt!

DET HÄR BEHÖVS FÖRUTOM BYGGSATSEN

En två kanals radio, ett 7.2V/1200mAh ack-paket samt en laddare.

OFF-ROAD RACER RAIDER 2WD

ELECTRIC POWERED RACING BUGGY

1:10 SCALE
No. 3184



- 1 LARGE BUMPER TO PROTECT BUGGY FROM COLLISION.
- 2 RELIABLE LIGHT, FRICTION SHOCKS FRONT AND REAR.
- 3 BLOCK PATTERN FRONT TIRE FOR DIRECTIONAL CONTROL.
- 4 STRONG, LIGHT WHEEL.
- 5 INDEPENDENT SUSPENSION FRONT/REAR FOR TOP HANDLING.
- 6 FLAT, ONE-PIECE, HIGH-STRENGTH CHASSIS.
- 7 SPEED CONTROLLER (3 FWD/1 REV; INCLUDED).
- 8 MIDSHIPS-MOUNTED STOCK 05 MOTOR (INCLUDED) FOR BEST BALANCE.
- 9 GEAR TYPE DIFFERENTIAL (INSIDE PROTECTIVE HOUSING).
- 10 SPIKE PATTERN REAR TIRE FOR TOP TRACTION.

- 1 Kraftig stötfångare av seg stark nylon.
- 2 Kraftiga friktions stötdämpare runt om.
- 3 Framdäck med klackmönster för bästa styrning.
- 4 Starka men lätta nylonfälgar.
- 5 Långa bärramar både fram och bak för bästa väghållning.
- 6 Chassie i ett stycke för enkel montering och styrka.
- 7 Förmonterat fartreglage med backfunktion.
- 8 Mittmonterad motor för balansen skull.
- 9 Växelhus som väl skyddar differential och växellåda.
- 10 Bakdäck med spetsiga nabbar för bästa grepp.

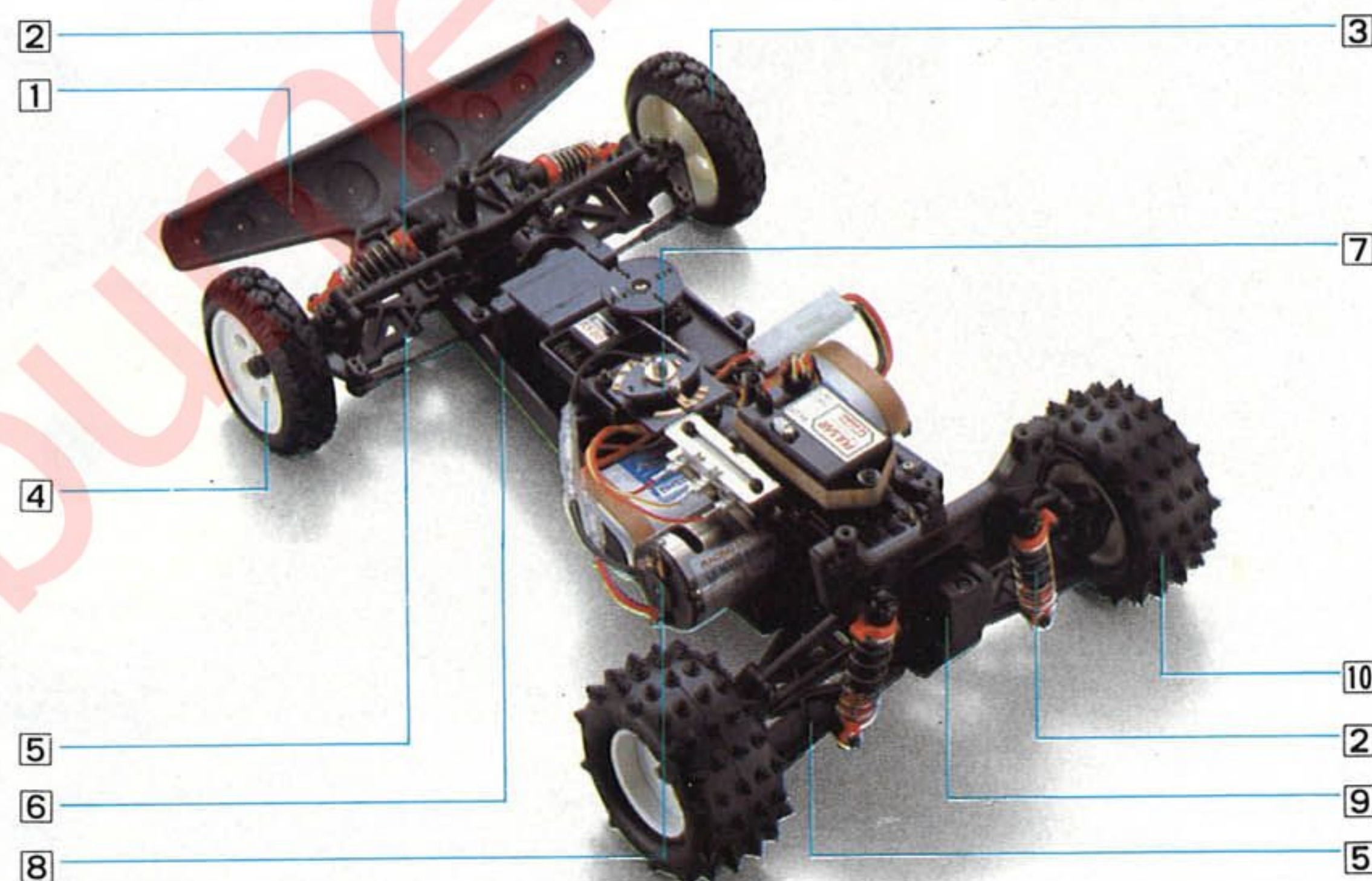

FRONT SUSPENSION. WISHBONE/PARALLEL ARM TYPE. LONG-TRAVEL FOR GOOD ROAD-HOLDING.



REAR SUSPENSION (SAME DESIGN). RELIABLE FRICTION SHOCK. ADJUSTABLE SHOCK MOUNTS.

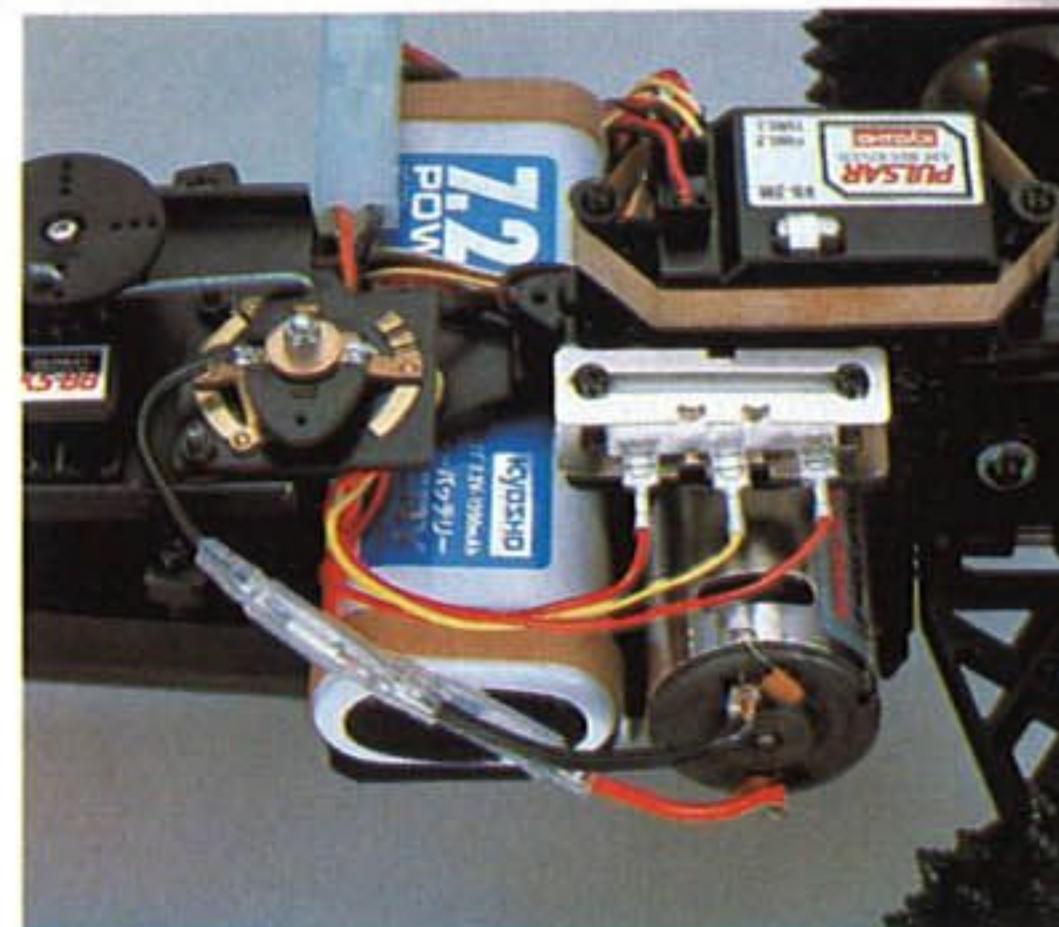

MIDSHIPS MOTOR POSITION AND LOW BATTERY MOUNT FOR BEST BALANCE. SPEED CONTROLLER.

Raider är visserligen en nybörjar buggy men det är lätt att se att det är duktiga Kyosho konstruktörer som ligger bakom. Erfarenheter som kommer från världsmästar konstruktioner.



THE FRONT WHEEL DRIVE COMPETITOR!

WITH THE DRIVING WHEELS PULLING IT THROUGH THE BENDS, THE *MAXXUM* WILL SHOW ITS TAIL TO THE PACK! THE EFFICIENT DRIVE SYSTEM MAKES THE MOST OF THE SUBSTANTIAL POWER OF THE TORQUEY FRONT-MOUNTED *LeMANS 240T* MOTOR (INCLUDED IN KIT), AND THE HIGH-QUALITY *ROTARY* SPEED CONTROLLER (ALSO INCLUDED) GIVES PRECISE CONTROL OF THE POWER. EVERY DETAIL OF THE *MAXXUM* IS DESIGNED FOR PERFORMANCE. THE *SUSPENSION* HAS EXTRA-LENGTH WISHBONES FOR LONG WHEEL TRAVEL, AND THE PREMIUM QUALITY *PRESSURE SHOCK* ABSORBERS KEEP IT ALL UNDER CONTROL ON ROUGH GROUND. THERE'S A FULL RANGE OF *SUSPENSION ADJUSTMENTS* FOR FINE-TUNING THE HANDLING, SO EVEN THE EXPERT CAN SET IT TO HIS LIKING. BUT THE BEGINNER WILL BE ABLE TO GET GREAT PERFORMANCE OUT OF THIS SCORCHER, TOO. THIS WILL BE THE TWO-WHEEL DRIVE BUGGY TO BEAT, AND THE STREAMLINED, STYLISH, BODY SAYS SO! THE ASSEMBLY INSTRUCTIONS ARE CLEAR AND EASY TO FOLLOW, SO ANYONE CAN PUT THE *MAXXUM* TOGETHER AND BE COMPETITIVE.

REQUIRED FOR OPERATION / RECOMMENDED FOR BEST APPEARANCE (NOT INCLUDED)

● 7.2V-1200mAh NiCd BATTERY ● CHARGER FOR BATTERY ● RADIO CONTROL SET (TWO-CHANNEL TWO-SERVO) ● POLYCA COLOR PAINTS ● MICRON LINE STRIPING TAPE

TECHNICAL DATA

① Length/350mm (13.8") ② Width/240mm (9.4") ③ Height/130mm (5.1") ④ Wheelbase/260mm (10.2") ⑤ Ground clearance/35mm (1.4") ⑥ Front track/200mm (7.9") ⑦ Rear track/200mm (7.9") ⑧ Tires (F R) / $\phi 85 \times 37$ mm ⑨ Weight (ready-to-run) / 1500g (3.3 lb) ⑩ Gear ratio/9:1 ⑪ Motor (included) / LeMans 240ST ⑫ Battery (not included) / 7.2V-1200mAh NiCd ⑬ Radio control set (not included) / Two-channel

FRAMHJULSDRIVEN FULL RACER

Det här är en full-racer för Dig som vill tävla eller åtminstone köra en fullfjädrad racer. Maxxum FF är den första framhjulsdrevena riktiga tävlingsbuggyn på marknaden. Konstruktionen bygger till stora delar på världens i särklass mest framgångsrika tävlingsbuggy - Optima familjen! Allt material har valts med största omsorg för att den skall tåla mycket stryk. Motorn är en supervass LeMans 240ST så Du behöver inte riskera att bli efter i starten!

DET HÄR BEHÖVS FÖRUTOM BYGGSATSEN

En två kanals radio, ett 7.2V/1200mAh ack-paket samt en laddare.

OFF-ROAD RACER *MAXXUM FF*

ELECTRIC POWERED RACING BUGGY

1:10 SCALE
No. 3127



- ① HIGH-QUALITY *PRESSURE* SHOCK ABSORBERS.
- ② LOW-PROFILE PIN-TYPE ALL-PURPOSE TIRES.
- ③ HEIGHT ADJUSTER/TRAVEL LIMITER.
- ④ FRONT-MOUNTED MOTOR (INCLUDED) FOR DIRECT DRIVE AND BEST BALANCE.
- ⑤ 17S ALLOY ALUMINUM CHASSIS/FRP UPPER PLATE.
- ⑥ GEAR-TYPE DIFFERENTIAL, SEALED FROM DUST.
- ⑦ REAR SUSPENSION: FULL CAMBER/TOE-IN ADJUSTMENT.
- ⑧ HIGH-QUALITY *ROTARY* SPEED CONTROLLER (INCLUDED).
- ⑨ STYLISH WHEELS.

- 1 Greppiga lågprofilsdäck.
- 2 Hjulupphängning bak med full justerbarhet.
- 3 Kyosho original stötdämpare med tryckmembran.
- 4 Nya "rotary" fartreglaget.
- 5 Helt kapslat växelhuss med differential.
- 6 Justering av markfrigången för maximal väghållning.
- 7 Chassie av flygaluminium och glasepxi.
- 8 Frontmonterad motor för maximalt grepp.
- 9 Tuff design med racig kaross och spoiler.

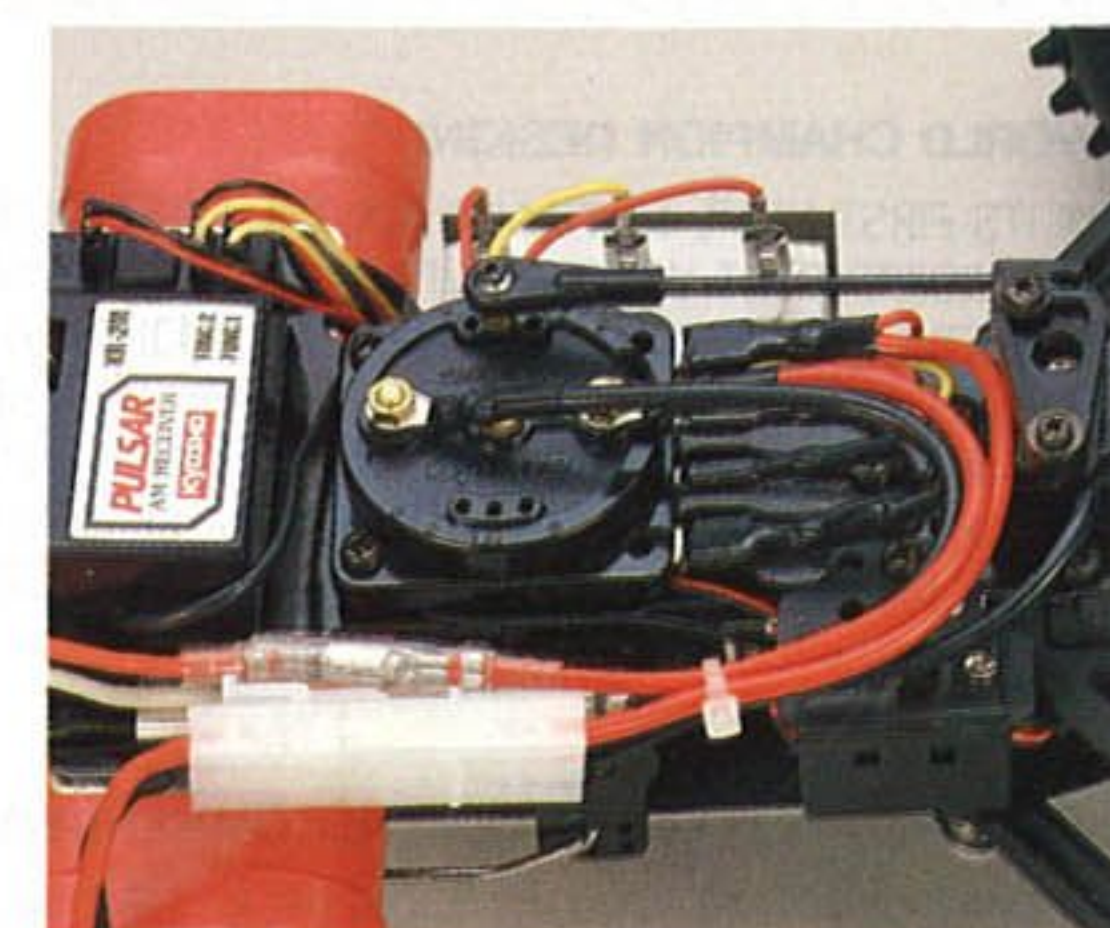
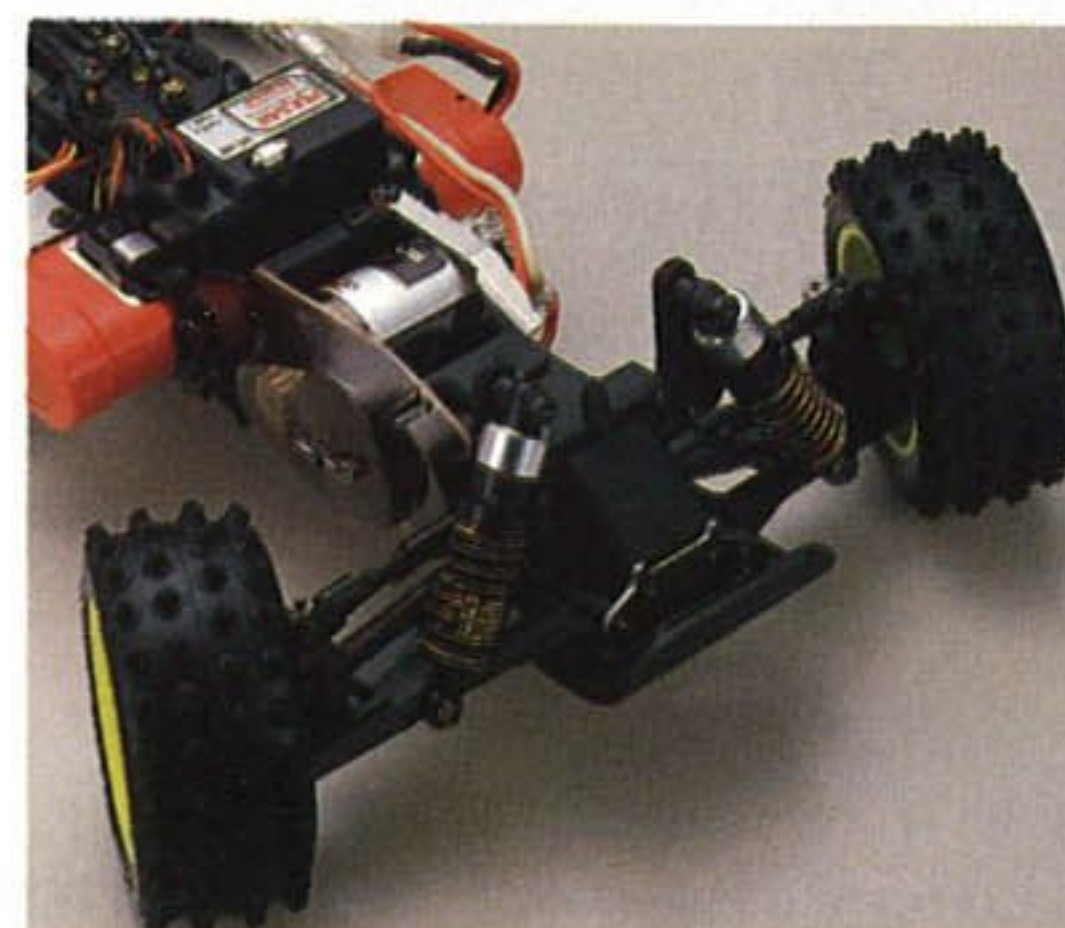
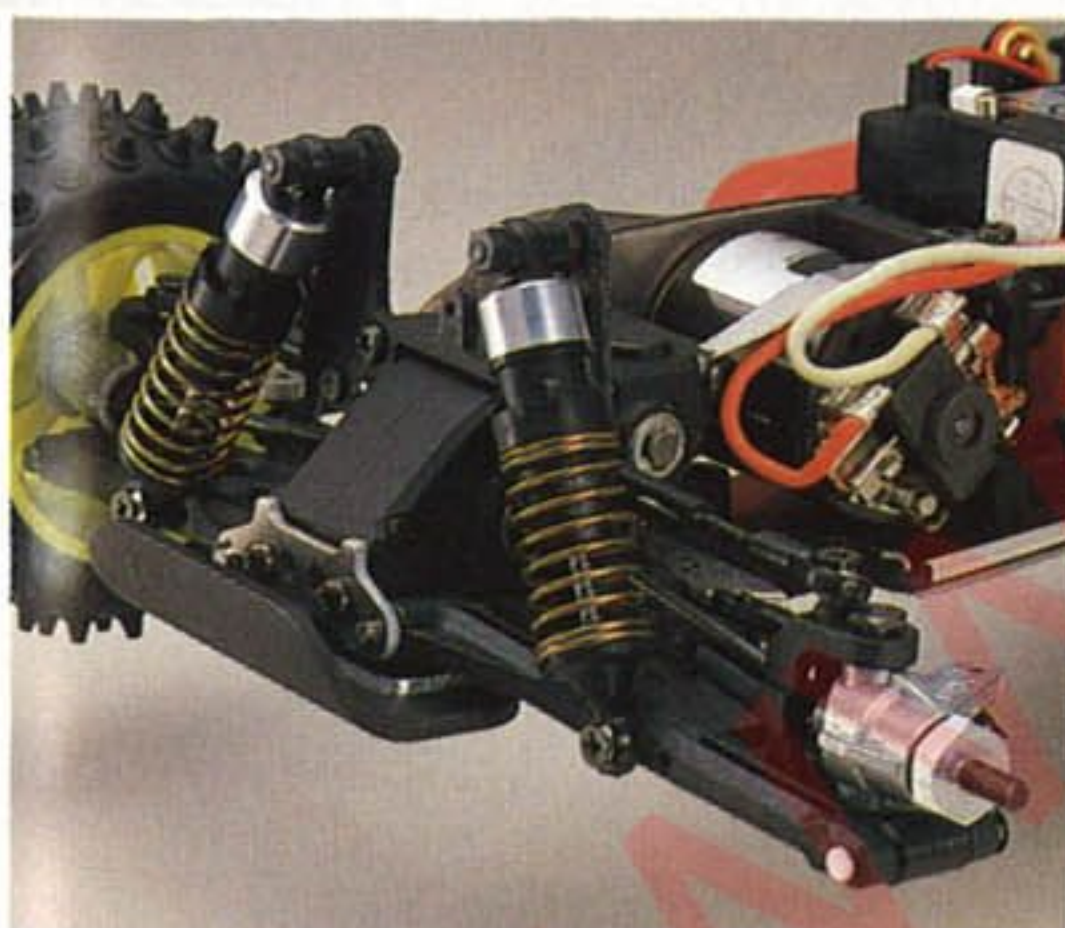
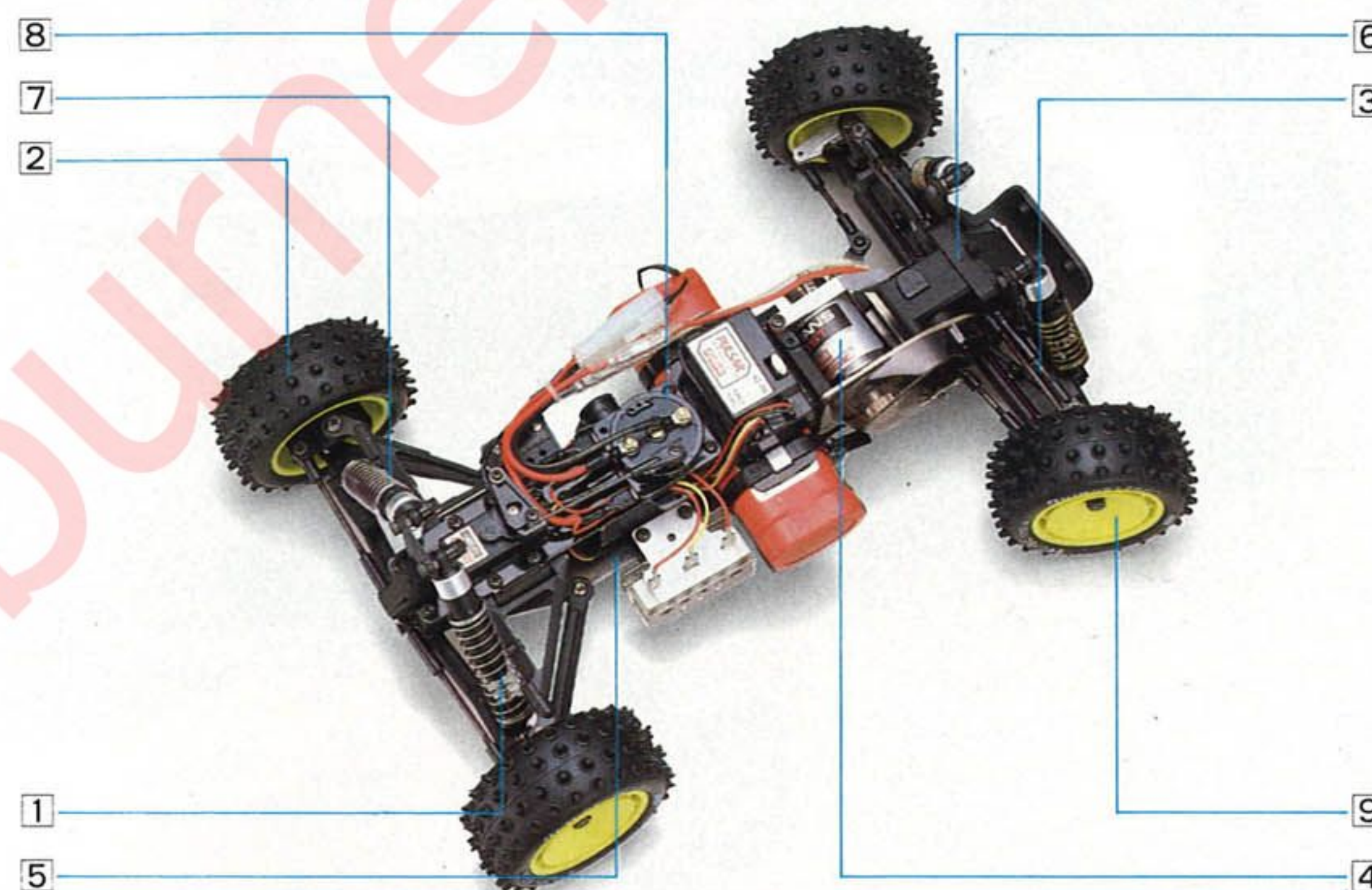

ULTRA-LONG SUSPENSION ARMS AND *PRESSURE* SHOCKS TO SOAK UP BUMPS. ADJUSTABLE TRAVEL AND HEIGHT.

DOUBLE-WISHBONE REAR. ADJUSTABLE CAMBER AND TOE-IN FOR CHASSIS TUNING. EASY GEOMETRY CHANGES.

WISHBONE AND ARM FRONT SUSPENSION WITH *PRESSURE* SHOCKS. COMPACT MOTOR/DIFF UNIT.

HIGH-QUALITY *ROTARY* SPEED CONTROLLER (INCLUDED). SOLID SILVER CONTACTS. 3 SPEEDS FORWARD/1 REVERSE.

Maximalt långa bärramar och fulla justeringsmöjligheter för att erhålla bästa geometri i hjulupphängningen.

Kompakt och robust framvagn med riktiga oljestötdämpare.

Nytt super robust fartreglage för minimala förluster och enkel installation.



WORLD CHAMPION DESIGN!

IN ITS FIRST YEAR, *ULTIMA* TOOK THE FIRST THREE PLACES IN THE IFMAR WORLD CHAMPIONSHIPS! THE ALL-INDEPENDENT WISHBONE/PARALLEL-ARM SUSPENSION, WITH ITS EFFECTIVE OIL-FILLED SHOCK ABSORBERS, IS BASED ON THAT OF THE FAMOUS *OPTIMA*, BUT HAS EVEN LONGER WHEEL TRAVEL (40MM!) TO KEEP *ULTIMA* RUNNING TRUE ON THE ROUGHEST TRACKS. THE MABUCHI RS-540 MOTOR IS REAR-MOUNTED FOR OPTIMUM 2WD WEIGHT DISTRIBUTION, AND DEVELOPS PLENTY OF POWER. THE POWER REACHES THE REAR WHEELS THROUGH A SEALED GEARBOX/DIFFERENTIAL UNIT (FACTORY ASSEMBLED). THE ALUMINUM CHANNEL/TRUSS CHASSIS RESISTS TWISTING AND FLEXING.

REQUIRED FOR OPERATION/RECOMMENDED FOR BEST APPEARANCE(NOT INCLUDED)

- TWO-CHANNEL RADIO CONTROL SET ● 7.2V-1200mAh OR 7.2V-1700mAh NiCd BATTERY
- CHARGER FOR NiCd BATTERY ● POLYCA COLOR PAINT ● MICRON LINE STRIPING TAPE

Technical Data

①Length/360mm(14.2in)②Width/240mm(9.4in)③Height/130mm(5.1in)④Wheelbase/268mm(10.6in)⑤Ground Clearance/40mm(1.6in)⑥Front Trach/200mm(7.9in)⑦Rear Track/200mm(7.9in)⑧Tires (F)φ70×20mm;(R)φ85×37mm⑨ Total Weight /1500g(3.3lb)⑩Gear Ratio/9:1⑪Motor/RS-540S(Included)⑫Battery/7.2V-1200mAh(Not included)⑬Radio/Two-channel(Not included)

1987 ÅRS TREDUBBLA VÄRLSMÄSTARE

Det här är basversion av Ultima - den buggy som varit så framgångsrik i den tvåhjuldrivna klassen under de senaste två åren. Även om den numera finns i två racigare versioner så är det här en bra början för Dig som siktar på en tävlingskarriär. Du bygger sedan enkelt vidare med kullager, vassare motorer och alla andra tävlingstillbehör som finns att få till denna racer. Den välkända Optima har även här fått lämna ifrån sig en del finesser för att göra Ultima till en racer. Materialvalet är som alltid i en äkta Kyosho-racer gjort med tanke på tävling!

DET HÄR BEHÖVS FÖRUTOM BYGGSATSEN

En två kanals radio, ett 7.2V/1200mAh ack-paket samt en laddare.

OFF-ROAD RACER *ULTIMA*

ELECTRIC POWERED RACING BUGGY

1:10 SCALE

No. 3115

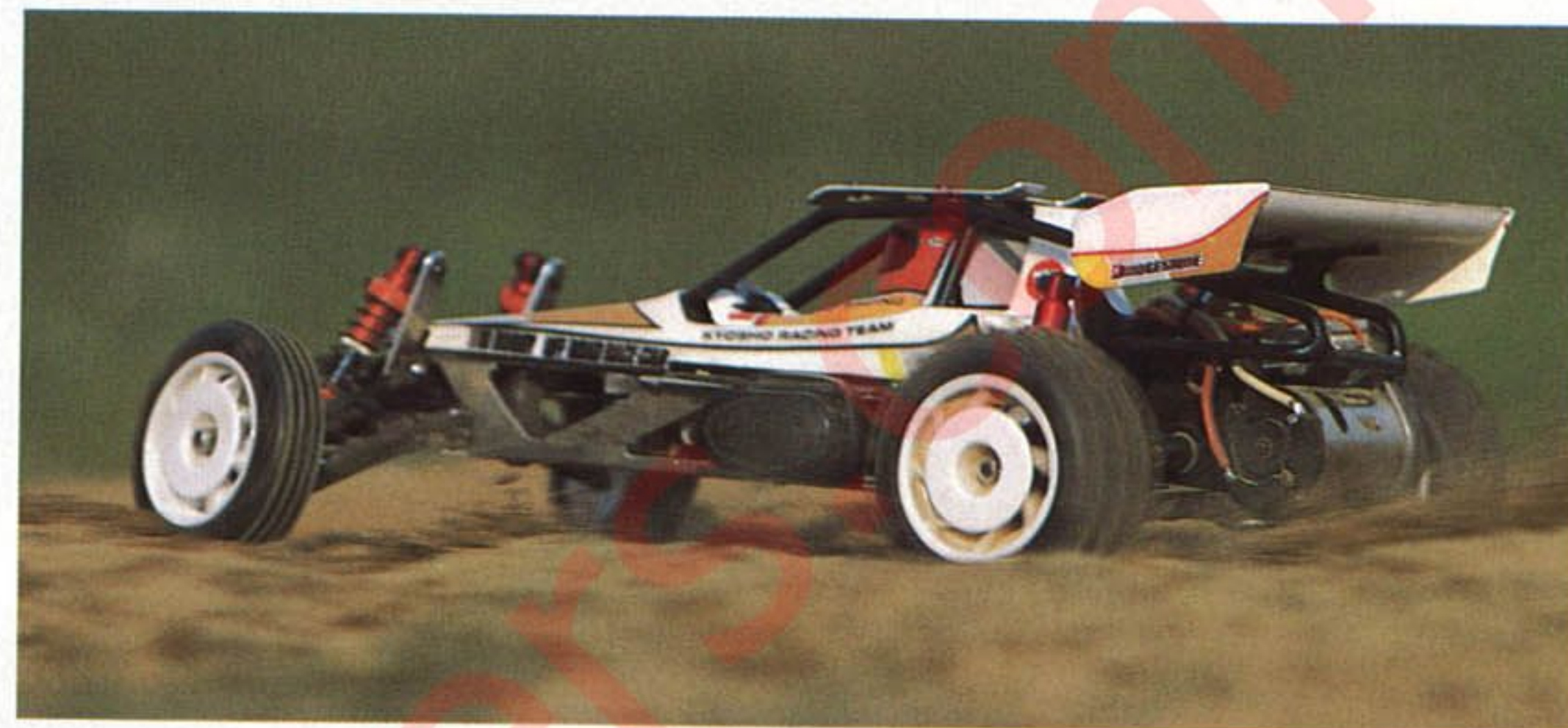

- 1 NEW-DESIGN LOW-PROFILE FRONT TIRE.
- 2 OVERSIZE OIL-FILLED SHOCK ABSORBER.
- 3 EXTRA-LONG PARALLEL WISHBONE/ARM FRONT SUSPENSION FOR UNEXCELLED SHOCK ABSORPTION.
- 4 STRONG NEW ALUMINUM PLATE/TRUSS CHANNEL-TYPE CHASSIS.
- 5 STYLISH, STRONG NYLON REAR WHEEL FOR LOW-PROFILE TIRE.
- 6 HEATSINK TO EXTEND EFFECTIVENESS OF SPEED-CONTROLLER RESISTOR.
- 7 POWERFUL, RELIABLE MABUCHI RS-540S MOTOR (INCLUDED IN KIT).
- 8 EXTRA-LONG PARALLEL WISHBONE/ARM REAR SUSPENSION.
- 9 LOW-PROFILE, HIGH-TRACTION PIN-SPIKE REAR TIRE.

- 1 Ribbade lågprofilsdäck.
- 2 Oljestötdämpare med aluminiumhus.
- 3 Extra långa bärarmar.
- 4 Tunnelchassie av flygaluminium och nylon.
- 5 Tuffa lågprofilfälgar av nylon.
- 6 Fartreglage motstånd med kylfläns.
- 7 Råstark Mabuchi 540S motor.
- 8 Kraftiga extra långa bärarmar.
- 9 Greppiga dubbade lågprofilsdäck.

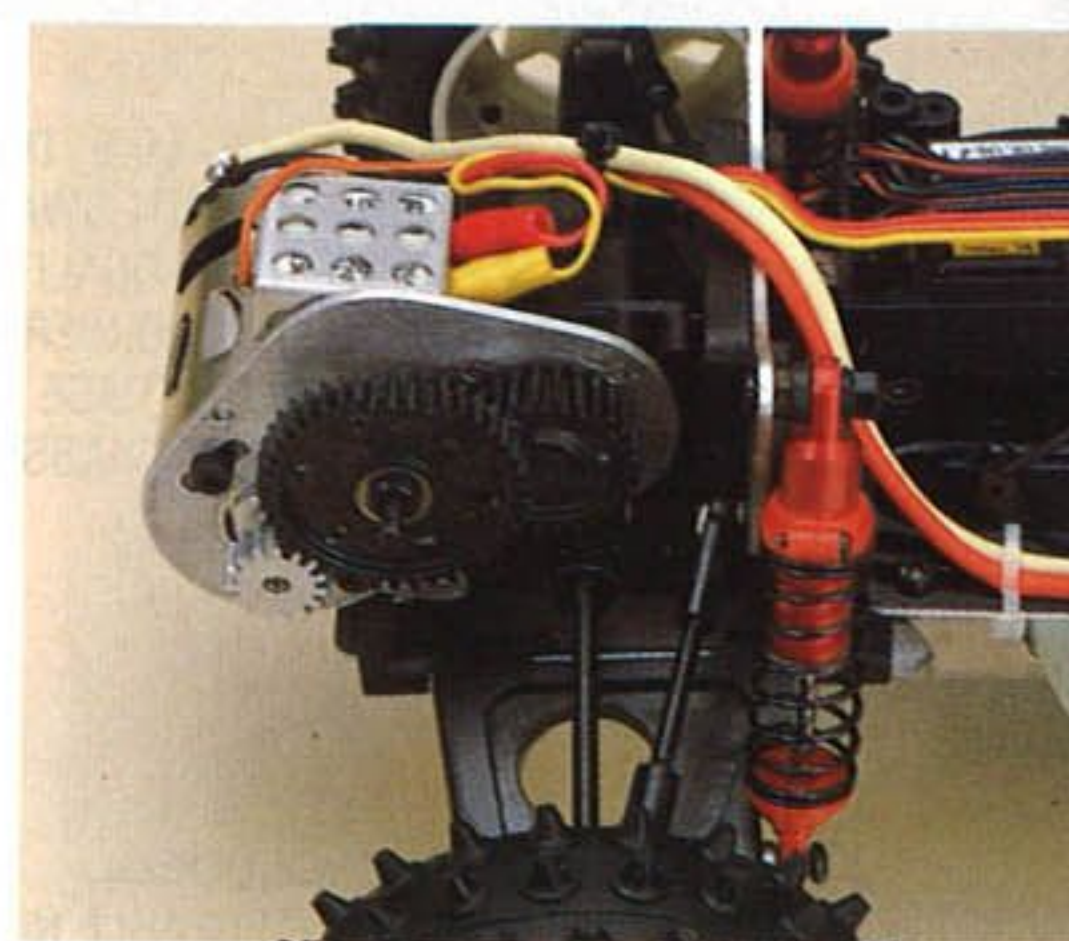
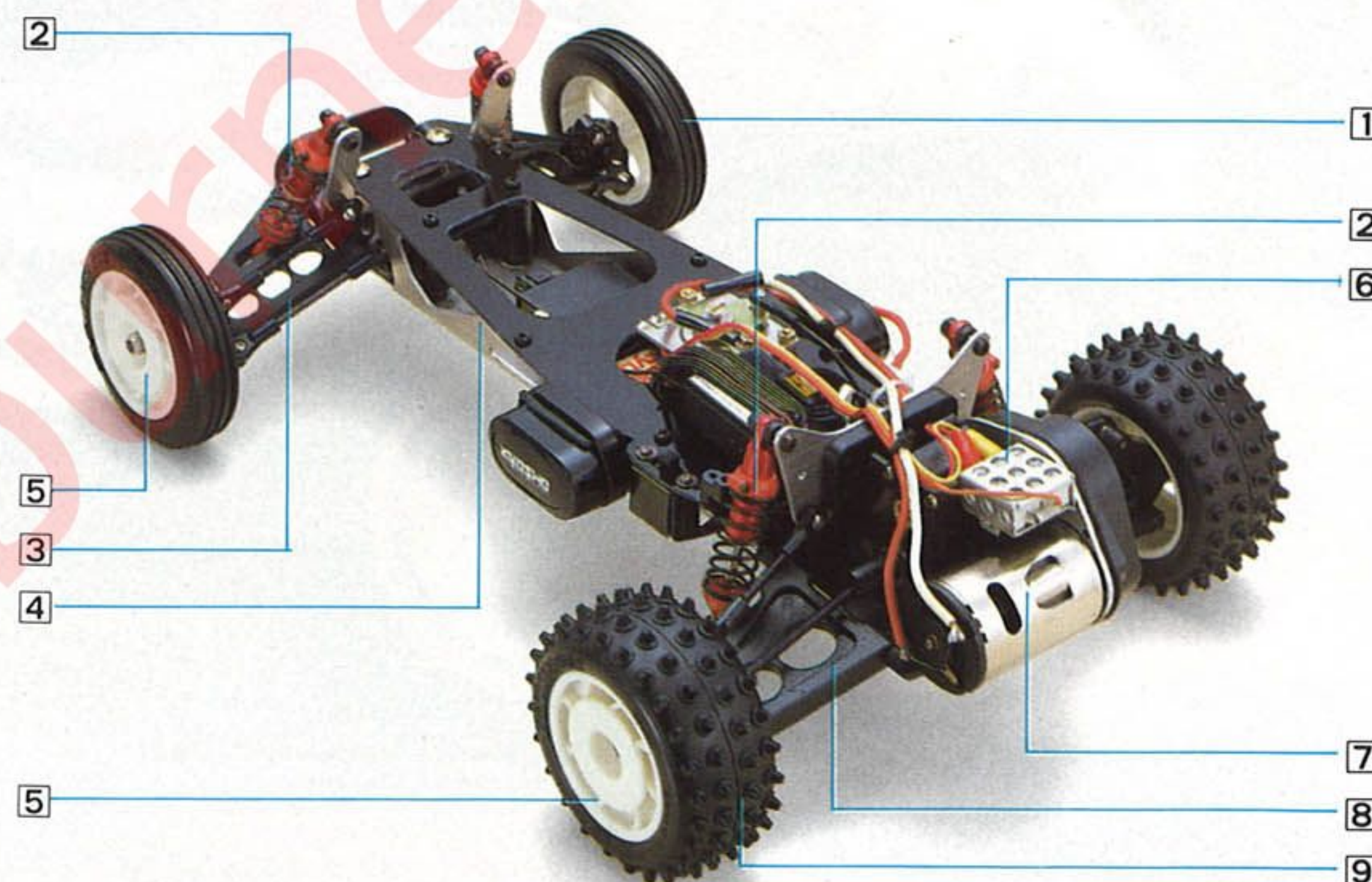

PARALLEL WISHBONE/ARM FRONT/REAR SUSPENSION. OIL-FILLED SHOCKS.

STRONG NYLON SUSPENSION PARTS. FOUR-WHEEL INDEPENDENT SUSPENSION.

CLOSE-MOUNTED GEARBOX FOR EFFICIENCY. GEAR-TYPE DIFFERENTIAL (FACTORY MADE). Kompakt växelhuss med enkelt utbytbar utväxling.

Smidiga men långa och starka bärarmar av glasfylld nylon är en av hemligheterna bakom framgångarna.

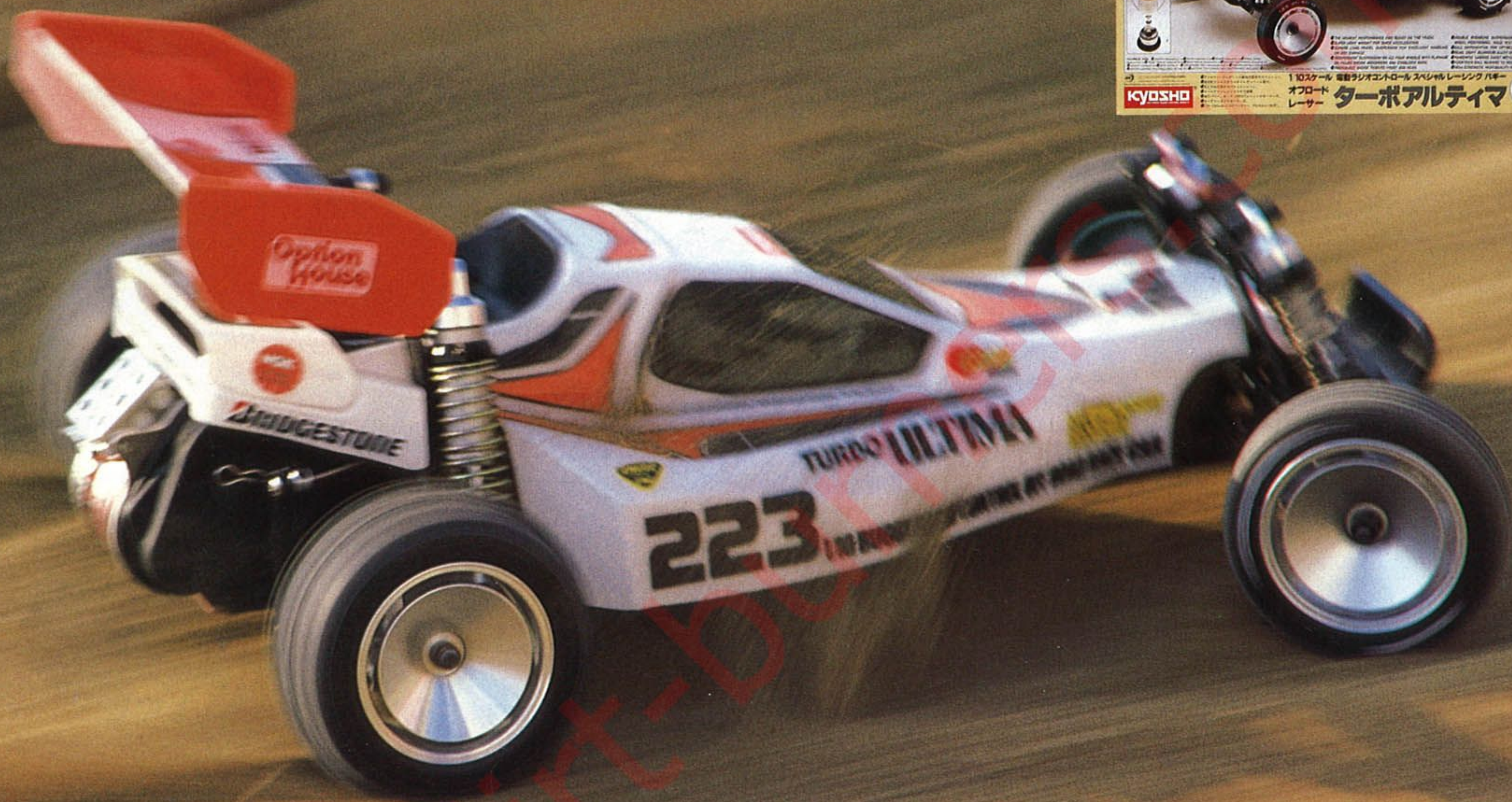

THE HOPPED-UP ULTIMA!

THE *TURBO ULTIMA* HAS ALL THE RACE-WINNING FEATURES OF THE ORIGINAL *ULTIMA*, LIKE THE SUPER-LONG TRAVEL ALL-INDEPENDENT SUSPENSION, AND HAS A LOAD OF EXTRA FEATURES. ANTI-SWAY BARS FRONT AND REAR. LIGHT, EFFICIENT, BALL-TYPE DIFFERENTIAL. *OPTION HOUSE* HIGH-QUALITY REAR TIRES AND UNIVERSAL-JOINTED SWING SHAFTS. SUPER EFFECTIVE *PLATINUM* SHOCK ABSORBERS. HEAVY DUTY *ROTARY* SPEED CONTROLLER (INCLUDED) WITH SILVER CONTACTS AND SHIELDED CASE (3 FWD/1 REV). POWERFUL *LeMANS 240ST* MOTOR (INCLUDED). STRONG, LIGHT ALLOY ALUMINUM CHASSIS AND FRP SHOCK TOWERS. KIT INCLUDES FULL SET OF 14 BALL BEARINGS.

REQUIRED FOR OPERATION / RECOMMENDED FOR BEST APPEARANCE (NOT INCLUDED)

●RADIO CONTROL SET (TWO-CHANNEL) ●BATTERY (7.2V-1200mAh OR 7.2V-1700mAh RECHARGEABLE NiCd BATTERY) ●BATTERY CHARGER FOR NiCd BATTERY ●POLYCA COLOR PAINT ●MICRON LINE STRIPING TAPE

Technical Data

①Length/360mm(14.2) ②Width/240mm(9.4) ③Height/130mm(5.1) ④Wheelbase/268mm(10.6) ⑤Ground Clearance/40mm(1.6) ⑥Front Trach/200mm(7.9) ⑦Rear Track/200mm(7.9) ⑧Tires/(F)φ70×20mm;(R)φ85×37mm
⑨Weight/1500g(3.3lb) ⑩Gear ratio/9:1 ⑪Motor/LeMans 240ST(included) ⑫Battery(not included)"/stick" type 7.2V-1200mAh ⑬Radio control/set(not included)/two-channel

TURBO - EN SUPERRUSTAD ULTIMA

TurboUltima - helt enkelt en fullt utrustad racer där inte mycket övrigt finns att önska. Bland de tvåhjulsdrevena är bara ProUltima, direkt avsedd för tävlingsbruk på toppnivå, mer välutrustad. Allt det här är standardutrustning: krängningshämmare både fram och bak, kromade fälgar, OptionHouse bakdäck, Platina tryckoljestötdämpare, kuldifferential, helt kullagrad, supervass LeMans 240ST motor, "rotary" fartreglage och mycket mer!

DET HÄR BEHÖVS FÖRUTOM BYGGSATSEN

En två kanals radio, ett 7.2V/1200 mAh ack-paket samt en laddare.

OFF-ROAD RACER *TURBO ULTIMA*

ELECTRIC POWERED SPECIAL RACING BUGGY

1:10 SCALE

No. 3181



- 1 LOW-PROFILE GROOVE-TREAD FRONT TIRES.
- 2 STRONG, LIGHT CHROME-FINISH NYLON WHEELS.
- 3 EXTRA-LONG DOUBLE WISHBONE SUSPENSION FRONT AND REAR.
- 4 PLATINUM OIL-FILLED SHOCKS FRONT AND REAR.
- 5 FIBERGLASS SHOCK TOWERS FRONT AND REAR.
- 6 STRONG ALUMINUM-ALLOY CHANNEL-TYPE CHASSIS.
- 7 FIBERGLASS RADIO PLATE.
- 8 NEW SHIELDED HEAVY DUTY ROTARY SPEED CONTROLLER.
- 9 ANTI-SWAY BARS FRONT AND REAR.
- 10 BALL DIFFERENTIAL.
- 11 POWERFUL LeMANS 240ST MOTOR (INCLUDED).
- 12 OPTION HOUSE HIGH TRACTION SPIKE TIRES.
- 13 UNIVERSAL SWING SHAFTS (INCLUDED).

- 1 Ribbade lågprofilsdäck.
- 2 Lätta lågprofilsfälgar av krompläterad nylon.
- 3 Extra långa bärarmar av glasfylld nylon.
- 4 Kraftiga Platina-stötdämpare med tryckmembran.
- 5 Stötdämparfästen av glasepxi.
- 6 Tunnelchassie av flygaluminium med ...
- 7 ... radioplatta av glasepxi.
- 8 Nya "rotary" fartreglaget.
- 9 Krängningshämmare fram och bak.
- 10 Momentbegränsande kulldifferential.
- 11 Stark och ursnabb LeMans 240ST motor.
- 12 Greppiga OptionHouse bakdäck.
- 13 Drivaxlar med kardankoppling.

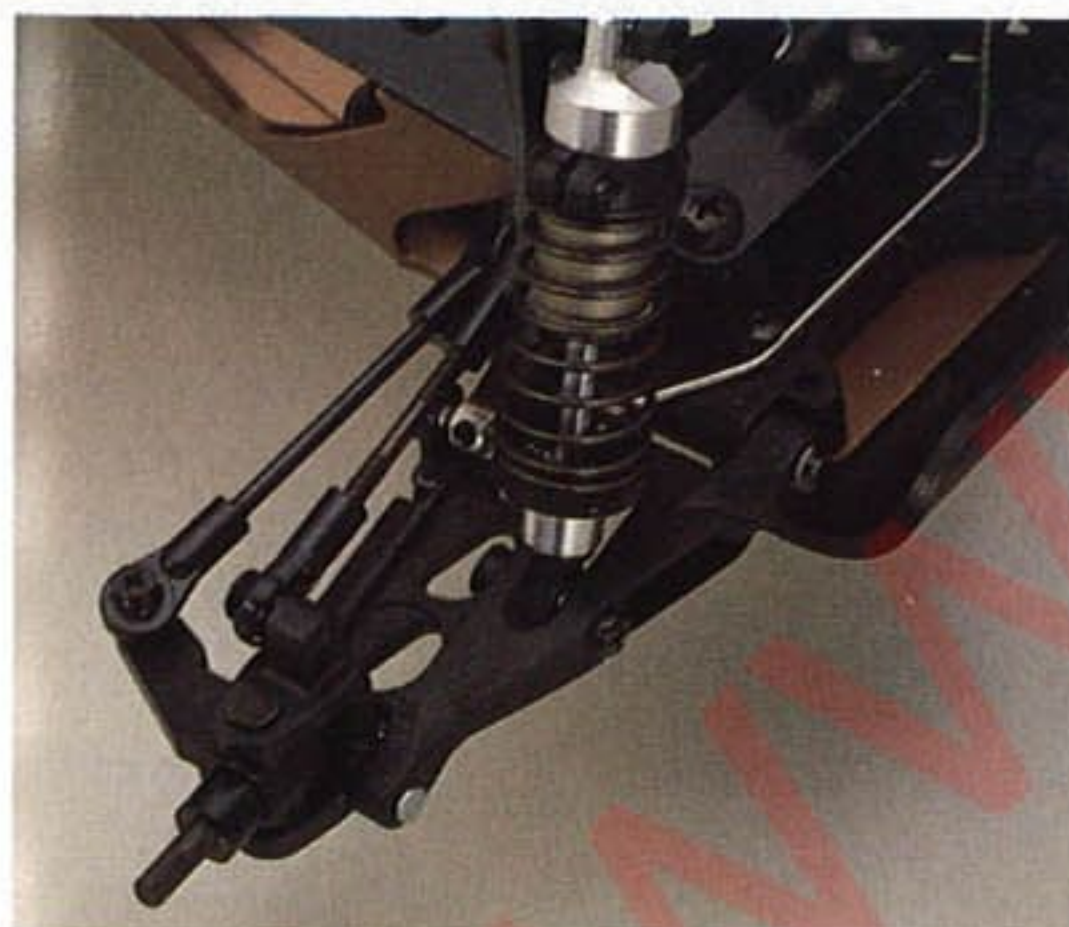

DOUBLE WISHBONE FRONT SUSPENSION WITH PLATINUM OIL-FILLED SHOCKS AND ANTI-SWAY BAR. STRONG NYLON PARTS.

Långa starka bärarmar ger den fina våghållningen och möjligheter till alla de justeringar som behövs.

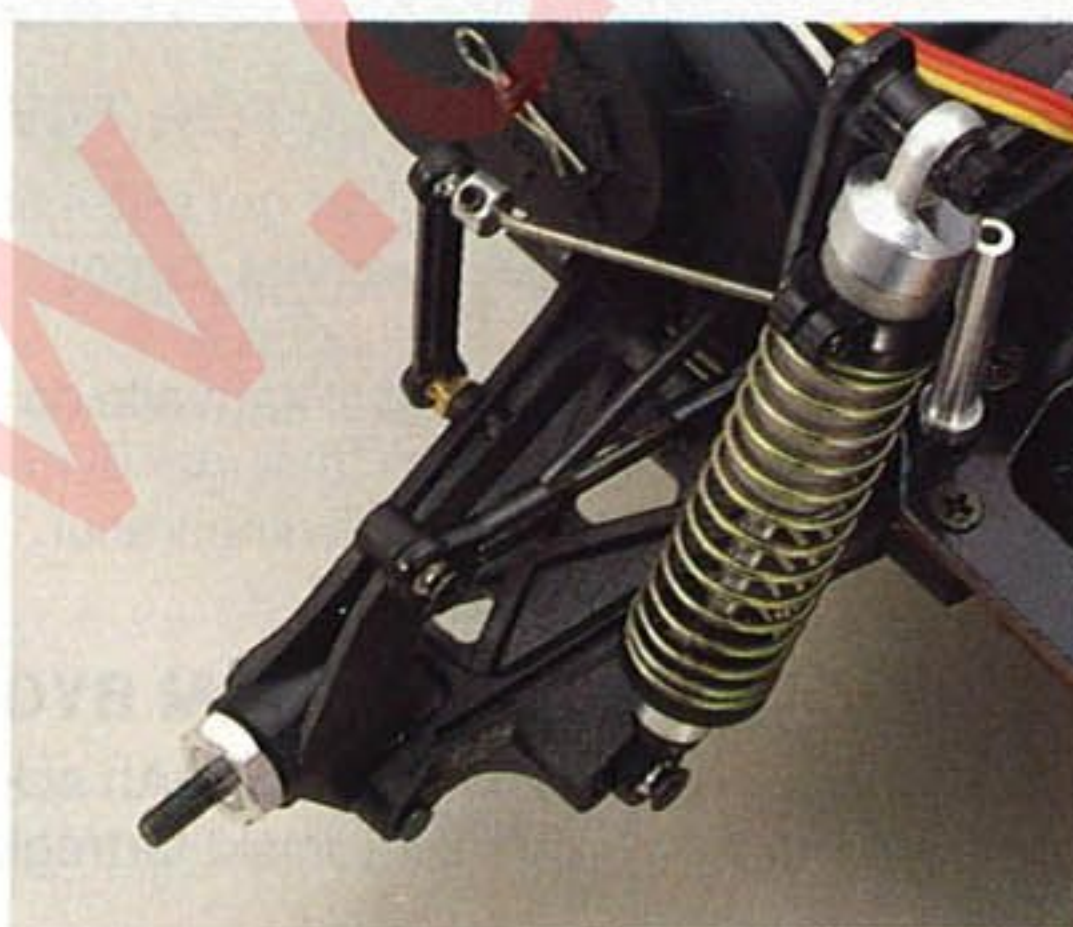

DOUBLE WISHBONE REAR SUSPENSION WITH PLATINUM OIL-FILLED SHOCKS AND ANTI-SWAY BAR LONG SUSPENSION TRAVEL.

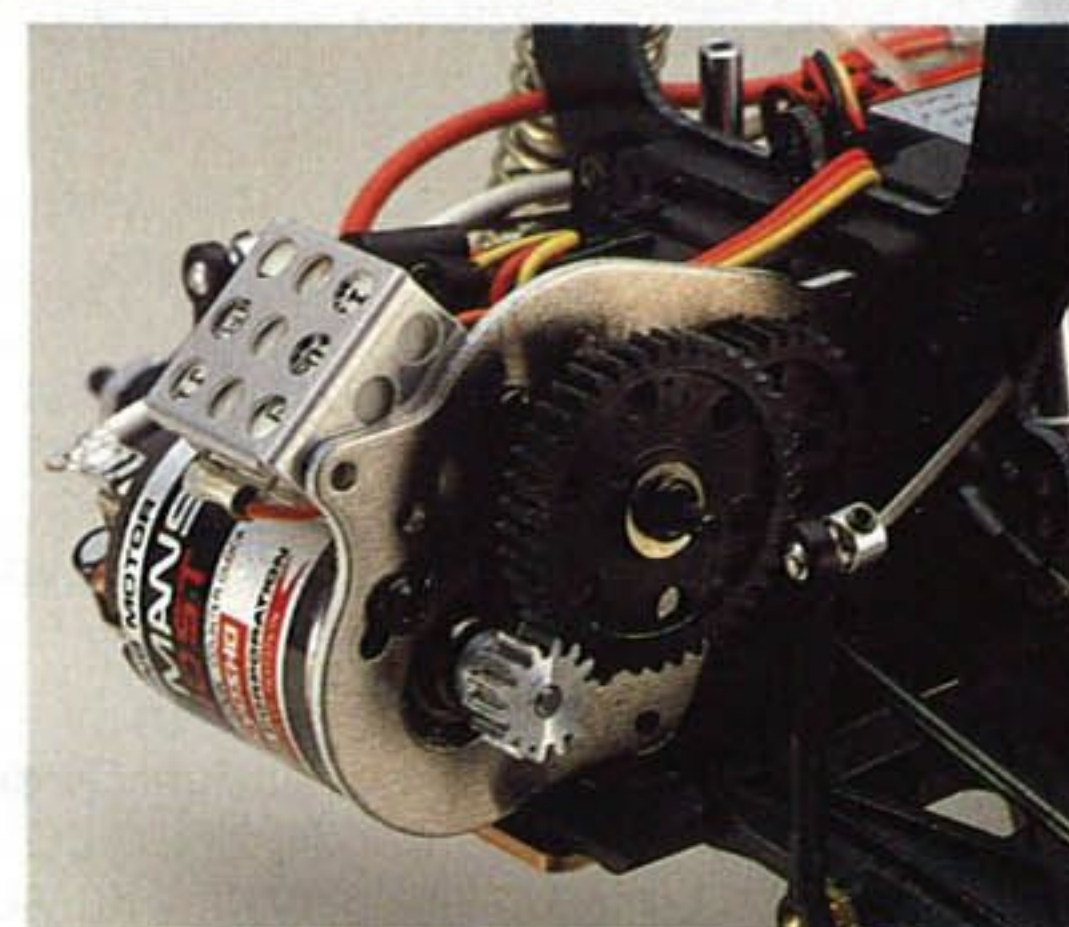

POWERFUL LeMANS 240ST MOTOR INCLUDED IN KIT GIVES OPTIMUM BALANCE OF TORQUE AND HIGH R.P.M. TIMING IS PRESET FOR BEST PERFORMANCE.

Den vassa LeMans 240ST motorn styrs av det nya robusta "rotary" fartreglaget som tål höga strömmar och sn abba omslag från fram till back.

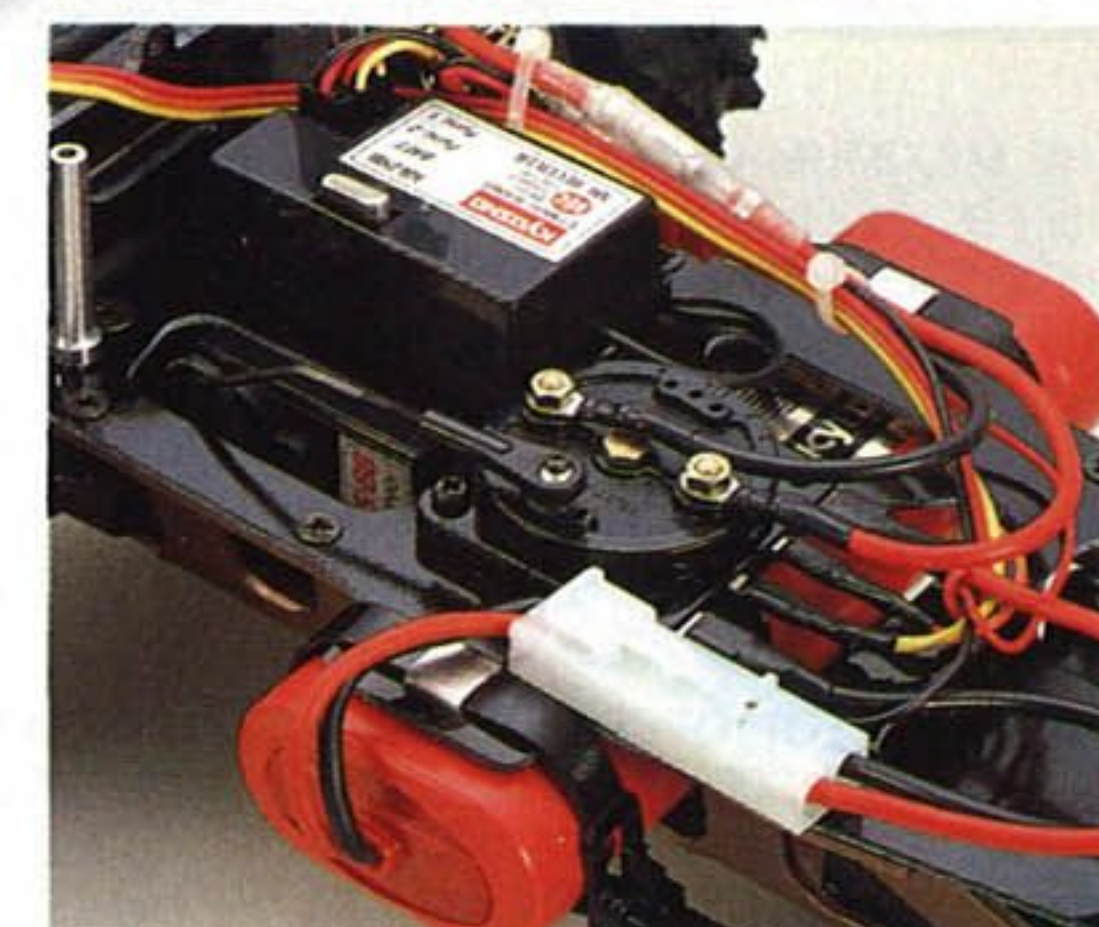

HEAVY DUTY ROTARY SPEED CONTROLLER SHIELDED TO KEEP OUT DUST. SILVER CONTACTS THREE FORWARD SPEEDS/ONE REVERSE.



THE MAXIMUM ULTIMA!

THE *PRO* INHERITS ALL THE FEATURES OF THE *ULTIMAS* THAT PLACED 1-2-3 IN THE 1987 IFMAR WORLD CHAMPIONSHIPS (2WD), AND HAS ALL NEEDED PERFORMANCE PARTS AS PART OF THE KIT. TOP-QUALITY *PRESSURE SHOCKS*. ANTI-SWAY BARS F/R. FULL BALL BEARING SET AND FULLY ADJUSTABLE FRONT AND REAR CAMBER (STATIC, PLUS CHANGE OF CAMBER WITH WHEEL TRAVEL). WHATEVER THE TRACK CONDITIONS, THE *PRO* CAN BE "DIALLED IN" TO STAY AHEAD OF THE PACK! LIGHT, STIFF ALLOY CHASSIS. MOUNTS FOR BOTH SADDLEPACK AND "STICK" BATTERIES. SPECIAL ALL-PURPOSE PIN-PATTERN TIRES ("MINI PIN" FRONT TREAD). SELECT YOUR FAVORITE MOTOR AND ELECTRONIC SPEED CONTROLLER AND DRIVE A WINNER! DRIVE A *PRO*!

REQUIRED FOR OPERATION/RECOMMENDED FOR BEST APPEARANCE (NOT INCLUDED)

●RADIO CONTROL SET (TWO-CHANNEL WITH STEERING SERVO AND ELECTRIC SPEED CONTROLLER) ●BATTERY (7.2V-1200mAh (STICK TYPE OR SADDLEPACK TYPE) OR 7.2V-1700mAh (STICK TYPE OR SADDLEPACK TYPE) RECHARGEABLE NiCd BATTERY) ●CHARGER FOR NiCd BATTERY ●MOTOR: LeMANS 240/360 TYPE

Technical Data

①Length/360mm (14.2") ②Width/240mm (9.4") ③Height/130mm (5.1") ④Wheelbase/268mm (10.6") ⑤Ground clearance/40mm (1.6") ⑥Front track/200mm (7.9") ⑦Rear track/200mm (7.9") ⑧Tires/(F) ϕ 75 \times 20mm; (R) ϕ 85 \times 37mm ⑨Weight/1550g (3 lb 7oz) ⑩Gear ratio/8.3: 1 ⑪Motor (not included)/LeMans 240/360 type ⑫Battery (not included)/7.2V-1700mAh NiCd ⑬Radio control set (not included)/Two-channel

TVÅHJULSRACER BARA FÖR TÄVLING

Det här är den Ultima Du väljer om siktet är direkt inställt på tävlingar. Det är marknadens mest välutrustade tvåhjuldrivna buggy. Allt som annars kan vara extrautrustning är standard.

I UltimaPro har Kyosho tagit tillvara alla de tävlingserfarenheter man samlat på sig genom tidigare Ultima framgångar i tävlingar över hela jorden. UltimaPro är inte någon buggy för "gemene man" utan en ren tävlingsracer. Därför kan tillgången vara begränsad!

DET HÄR BEHÖVS FÖRUTOM BYGGSATSEN

En två kanals radio, ett 7.2V/1200mAh ack-paket samt en laddare. Dessutom behövs en LeMans motor och ett elektroniskt fartreglage.

OFF-ROAD RACER *ULTIMA PRO*

ELECTRIC POWERED RACING BUGGY

1:10 SCALE

No. 3117



- 1 LONG-TRAVEL WISHBONE/PARALLEL ARM FRONT SUSPENSION. EASY CAMBER/TOE-IN ADJUSTMENT.
- 2 EXTRA-EFFECTIVE OIL-FILLED PRESSURE SHOCK ABSORBERS TO SOAK UP BUMPS.
- 3 STRONG, LIGHT FRP SHOCK MOUNT.
- 4 MOTOR. (NOT INCLUDED)
- 5 LONG-TRAVEL WISHBONE/PARALLEL ARM REAR SUSPENSION. EASY CAMBER ADJUSTMENT.
- 6 OVERSIZE AERODYNAMIC WING.
- 7 STRONG, LIGHT 17S ALLOY CHASSIS, PERFORATED FOR SADDLEPACK-TYPE BATTERIES.
- 8 LIGHTWEIGHT FRP UPPER CHASSIS PLATE.
- 9 LIGHT, EFFICIENT BALL-TYPE DIFFERENTIAL.
- 10 ANTI-SWAY BARS STANDARD FRONT AND REAR.
- 11 FINE-PITCH GEARS FOR SMOOTH POWER FLOW.
- 12 ALL-PURPOSE PIN-PATTERN TIRES. SPECIAL "MINI PIN" FRONT TREAD PATTERN.
- 13 EASY ADJUSTER FOR FRONT AND REAR STATIC CAMBER.

- 1 Extremt långa bärramar med snabbjusteringsmöjlighet.
- 2 Kyosho original Gold-stötdämpare (de bästa!).
- 3 Stötdämparfäste av glasepxi.
- 4 Alla LeMans motorer utom 360 passar.
- 5 Extra långa bärramar med snabbjustering för camber.
- 6 Stor formad ving för bästa balans.
- 7 Chassieplatta av flygaluminium avsett även för ack-paket av saddle-pack typ.
- 8 Radioplatta av styv glasepxi.
- 9 Differential av kul-typ.
- 10 Krängningshämmare runt om.
- 11 Extra fintandade drev för minimal friktion.
- 12 Nabbade däck av specialtyp fram & bak.
- 13 Enkelt justerbar statisk camber.

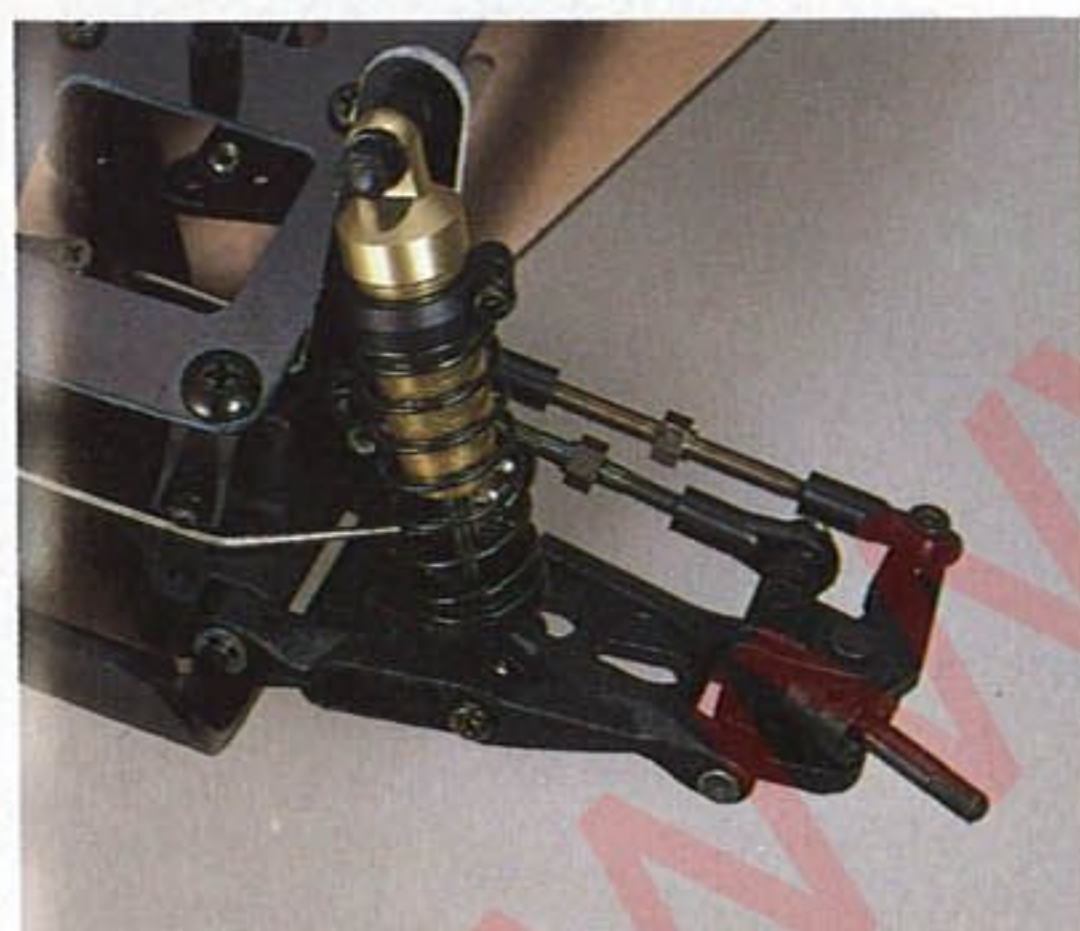
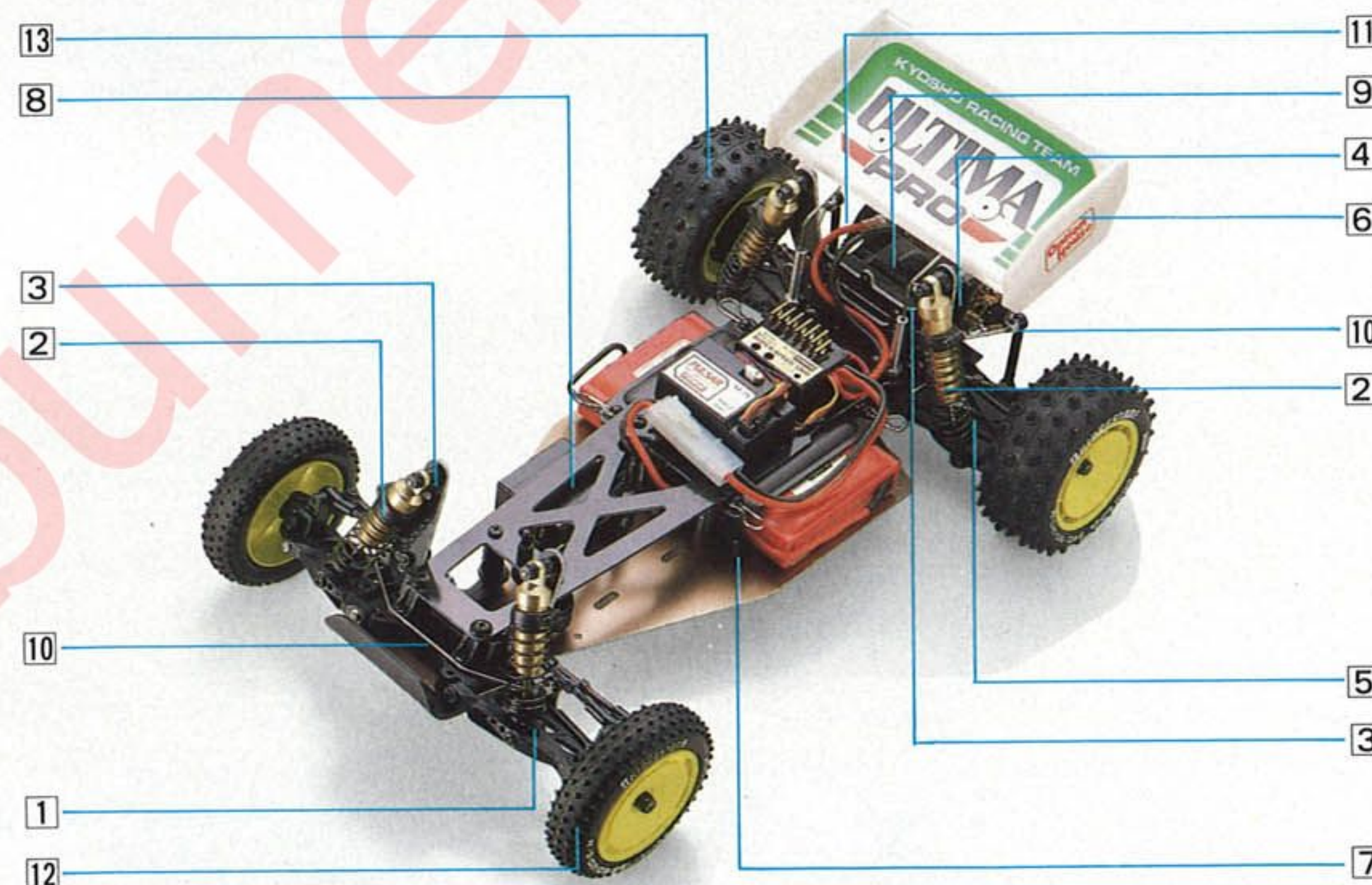

WISHBONE/ARM LONG-TRAVEL FRONT SUSPENSION. FULL CAMBER ADJUSTMENT. PRESSURE SHOCKS. ANTI-SWAY BAR STANDARD.

Fram och bakhjulsupphängningar som är så nära det perfekta det går att komma. Allt snabbjusterbart dessutom!

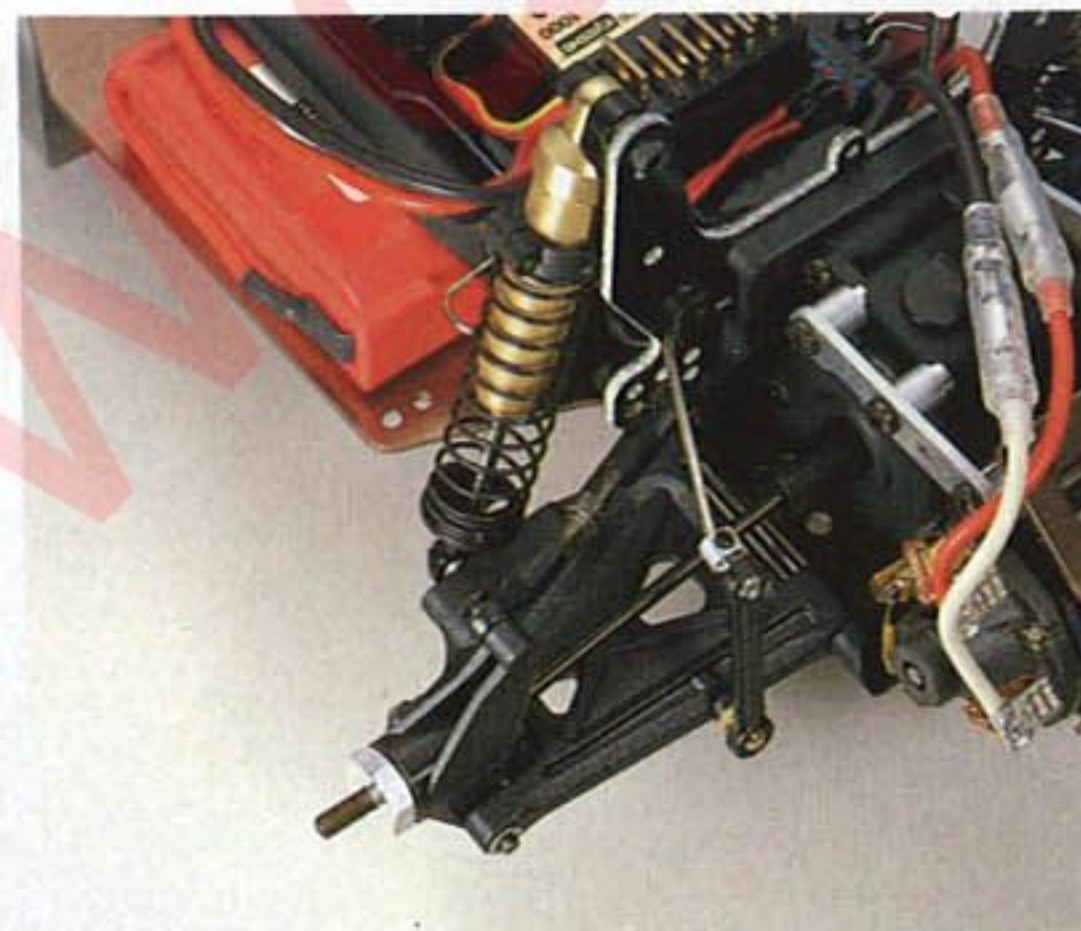

SAME FEATURES AS FRONT. EVEN MORE ADJUSTMENTS. (CHANGE OF CAMBER WITH TRAVEL CAN BE ADJUSTED F&R.)

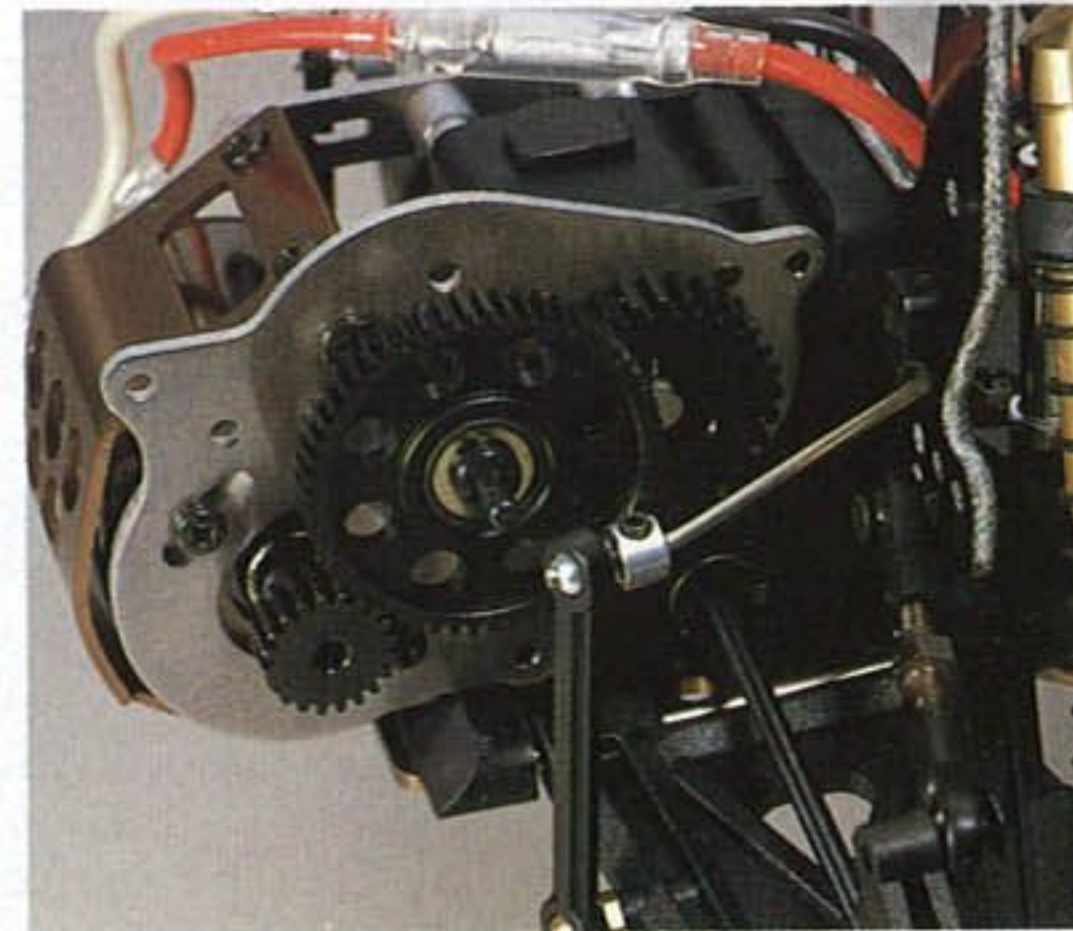

FINE-PITCH DRIVE GEARS FOR SMOOTH POWER FLOW. STRONG ENOUGH FOR THE MOST POWERFUL MOTORS.

Fintandade drev för minimal friktion.

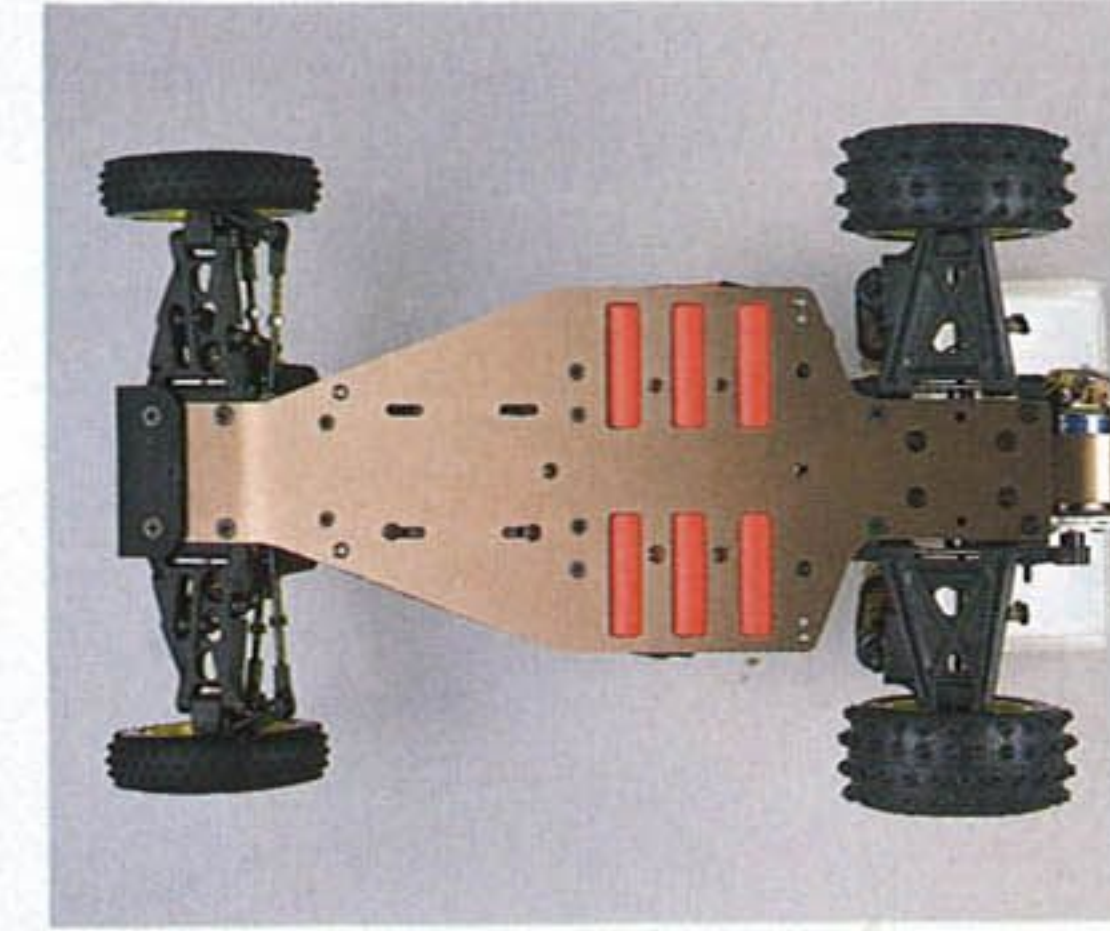

STRONG, LIGHT 17S ALLOY PLATE CHASSIS. CUTOUTS FOR SADDLE-PACK BATTERIES.

Superkraftigt chassie av flygaluminium

4WD OFF ROAD RACERS

■ AERO STREAK 4WD ■ SHADOW 4WD ■ OPTIMA MID
■ TURBO OPTIMA MID ■ TURBO OPTIMA MID SE
■ OPTIMA MID CUSTOM ■ OPTIMA MID CUSTOM SPECIAL
■ TURBO ROCKY



ELECTRIC POWERED RACING BUGGIES

	Name	Length	Height	Weight	Suspension	Shock Absorbers	Motor	Battery	Drive System	Potential For Hop-up*
4 W D	AEROSTREAK 4WD	400mm	160mm	1650g	(F) WS; (R) WS	4 Oil-filled	LeMans Stock 05	7.2V-1200mAh	Shaft	○
	SHADOW 4WD	350mm	160mm	1650g	(F) WS; (R) WS	4 Oil-filled	LeMans Stock 05	7.2V-1200mAh	Shaft	○
	OPTIMA MID	350mm	130mm	1600g	(F) WS; (R) WS	4 Oil-filled	LeMans 240ST	7.2V-1200mAh	Belt	◎
	TURBO OPTIMA MID	370mm	130mm	1600g	(F) WS; (R) WS	4 Oil-filled	240, 360 TYPE (Not included)	7.2V-1200mAh	Belt	◎
	TURBO OPTIMA MID SE	370mm	130mm	1600g	(F) WS; (R) WS	4 Oil-filled	LeMans 240ST	7.2V-1200mAh	Belt	◎
	OPTIMA MID CUSTOM	370mm	130mm	1600g	(F) WS; (R) WS	4 Oil-filled	LeMans 240ST	7.2V-1200mAh	Belt	◎
	OPTIMA MID CUSTOM SPECIAL	300mm	130mm	1600g	(F) WS; (R) WS	4 Oil-filled	240, 360 TYPE (Not included)	7.2V-1200mAh	Belt	◎
	TURBO ROCKY	380mm	120mm	1600g	(F) WS; (R) WS	4 Oil-filled	240, 360 TYPE (Not included)	8.4V-1200mAh	Chain	◎

(F)=FRONT, (R)=REAR, WS=DOUBLE WISHBONE or WISHBONE/PARALLEL ARM, TS=TRAILING ARM, SS=SLIDING PILLAR *◎High, ○Moderate, △Low



HIGH PERFORMANCE FOR THE ENTRY-LEVEL DRIVER!

THE *AERO STREAK 4WD* HAS ALL THE HIGH-PERFORMANCE FEATURES WITHOUT THE HIGH-PERFORMANCE PRICE! ROAD-HOLDING ON ROUGH OR SMOOTH IS VERY GOOD, DUE TO INDEPENDENT SUSPENSION WITH EFFECTIVE OIL-FILLED *PRESSURE SHOCKS* ON ALL FOUR WHEELS. ALL FOUR WHEELS PULL THE *STREAK* THROUGH CORNERS, AND ARE POWERED VIA *SHAFT DRIVE* AND *TWIN DIFFERENTIALS*. THE POWERPLANT IS A *LeMANS STOCK 05 MOTOR* (INCLUDED IN THE KIT), WITH TORQUE CHARACTERISTICS IDEALLY SUITED TO THE MODEL. THE MOTOR IS MOUNTED *MIDSHIPS* FOR THE BEST BALANCE. SPEED IS CONTROLLED BY A HIGH-QUALITY *ROTARY CONTROLLER*, WHICH HAS SOLID SILVER CONTACTS AND IS SEALED AGAINST DUST (INCLUDED). PERHAPS THE BEST FEATURE OF ALL, HOWEVER, IS THAT THE MODEL IS ALMOST COMPLETELY ASSEMBLED AT THE FACTORY, SO IT CAN BE ROAD-READY IN ONLY A SHORT TIME. THE MOST DIFFICULT TASK IS DECIDING WHAT COLOR SCHEME TO USE ON THE RACY BODY!

REQUIRED FOR OPERATION (NOT INCLUDED)

● 7.2V-1200mAh NiCd BATTERY ● CHARGER FOR BATTERY ● RADIO CONTROL SET (TWO-CHANNEL TWO-SERVO TYPE)

Technical Data

① Length/400mm (15.7") ② Width/244mm (9.6") ③ Height/160mm (6.3") ④ Wheelbase/265mm (10.4") ⑤ Ground clearance/32mm (1.3") ⑥ Front track/206mm (8.1") ⑦ Rear track/206mm (8.1") ⑧ Tires (F/R)/ $\phi 85 \times 38$ mm ⑨ Weight (track-ready)/1650g (3lb 10oz) ⑩ Gear ratio/7.7:1 ⑪ Motor (included)/LeMans Stock 05 ⑫ Battery (not included)/7.2V-1200mAh NiCd ⑬ Radio control set (not included)/Two-channel

NYBÖRJARENS DRÖMBIL - FYRHJULSDRIVEN

AeroStreak är på sätt och vis ett minst lika stort mästerverk som den tävlingsmässigt extremt framgångsrika Optima familjen. Här Kyosho lyckats kombinera erfarenheter från tävlingsidan med nybörjarens behov av enkelhet. För att ytterligare underlätta nybörjarens byggnation så är den delvis förmonterad. Den är också byggd för att tåla det mesta av vad en nybörjare kan hitta på. Och som pricken över i kommer den superhäftiga strömlinjeformade karossen. Rätt val som första buggy!

DET HÄR BEHÖVS FÖRUTOM BYGGSATSEN

En tvåkanals radio, ett 7.2V/1200mAh ack-paket samt laddare.

OFF-ROAD RACER AERO STREAK 4WD

ELECTRIC POWERED RACING BUGGY

1:10 SCALE
No. 3182



- 1 LOW-PROFILE, HIGH-TRACTION TIRE.
- 2 ABS DOUBLE-WISHBONE FRONT SUSPENSION.
- 3 FRONT DIFFERENTIAL.
- 4 EFFICIENT SHAFT DRIVE.
- 5 ROTARY SPEED CONTROLLER FOR SMOOTH CONTROL, RELIABLE ACTION.
- 6 LeMANS STOCK 05 MOTOR (INCLUDED).
- 7 ABS DOUBLE-WISHBONE REAR SUSPENSION.
- 8 RESILIENT POLYPROPYLENE FRONT BUMPER.
- 9 LARGE-CAPACITY OIL-FILLED SHOCK ABSORBERS.
- 10 PROTECTIVE TUB TYPE CHASSIS.
- 11 PROTECTIVE EASY-LOADING BATTERY HOLDER.
- 12 STRONG, LIGHT POLYPROPYLENE WHEEL.

- 1 Lågprofildäck med kraftiga slitstarka dubbar.
- 2 Kraftiga dubbla bärarmar av ABS.
- 3 Växelhus med inbyggd differential (även bak).
- 4 Lättskött kardandrift.
- 5 Nya "rotary" fartreglaget.
- 6 LeMans Stock05 motor ger bra styrka.
- 7 Kraftiga dubbla bärarmar av ABS.
- 8 Extremt slagtålig bumper av polypropylen.
- 9 Överdimensionerade oljestötdämpare.
- 10 Lådchassie som ger bra skydd för radioinstallationen.
- 11 Skyddande fack för ack-paketet med snabbclips.
- 12 Starka, snygga fälgar av polypropylen runt om.

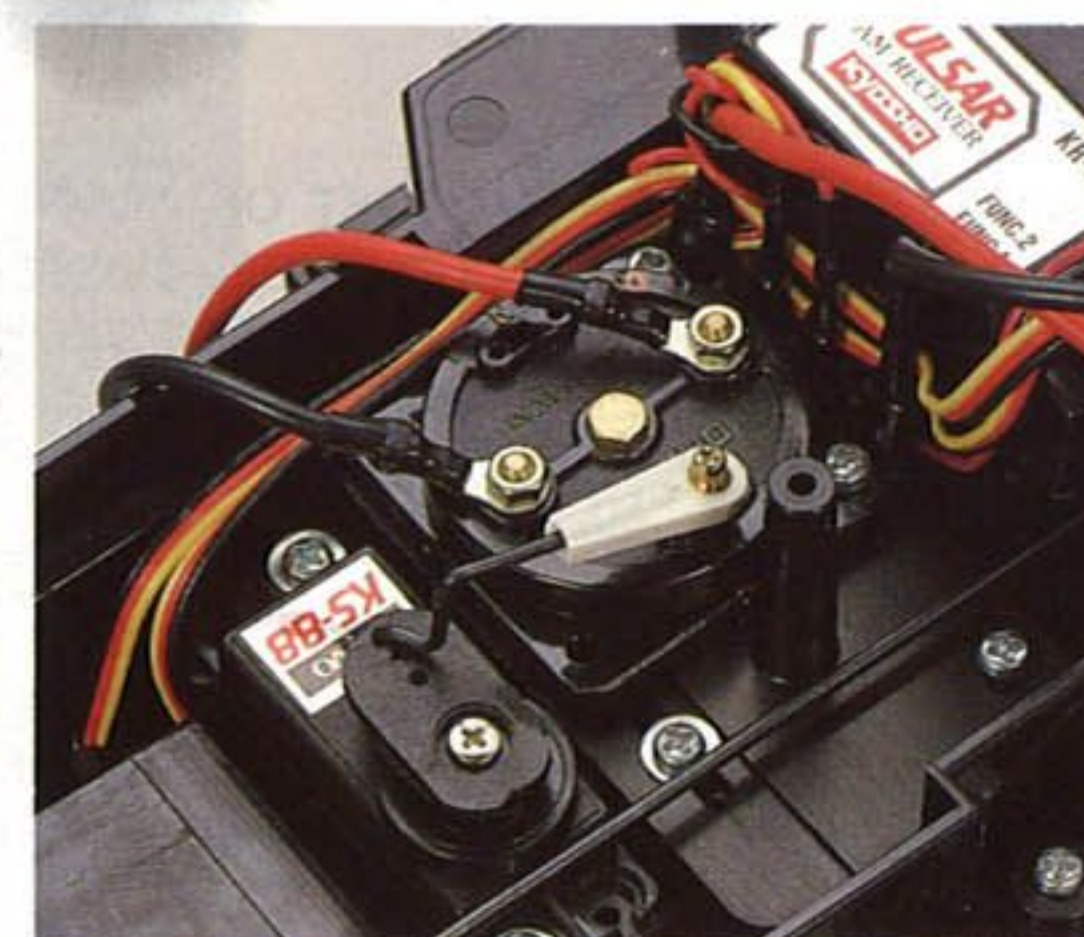
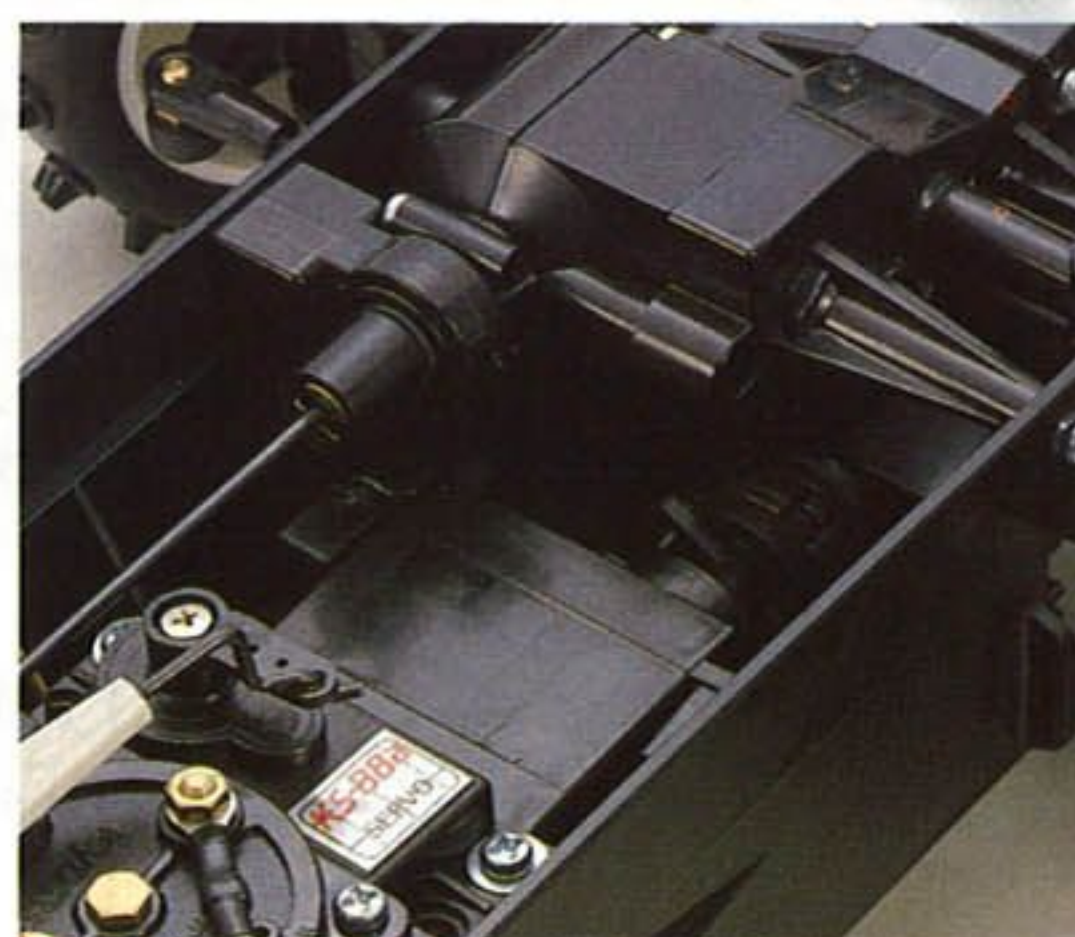
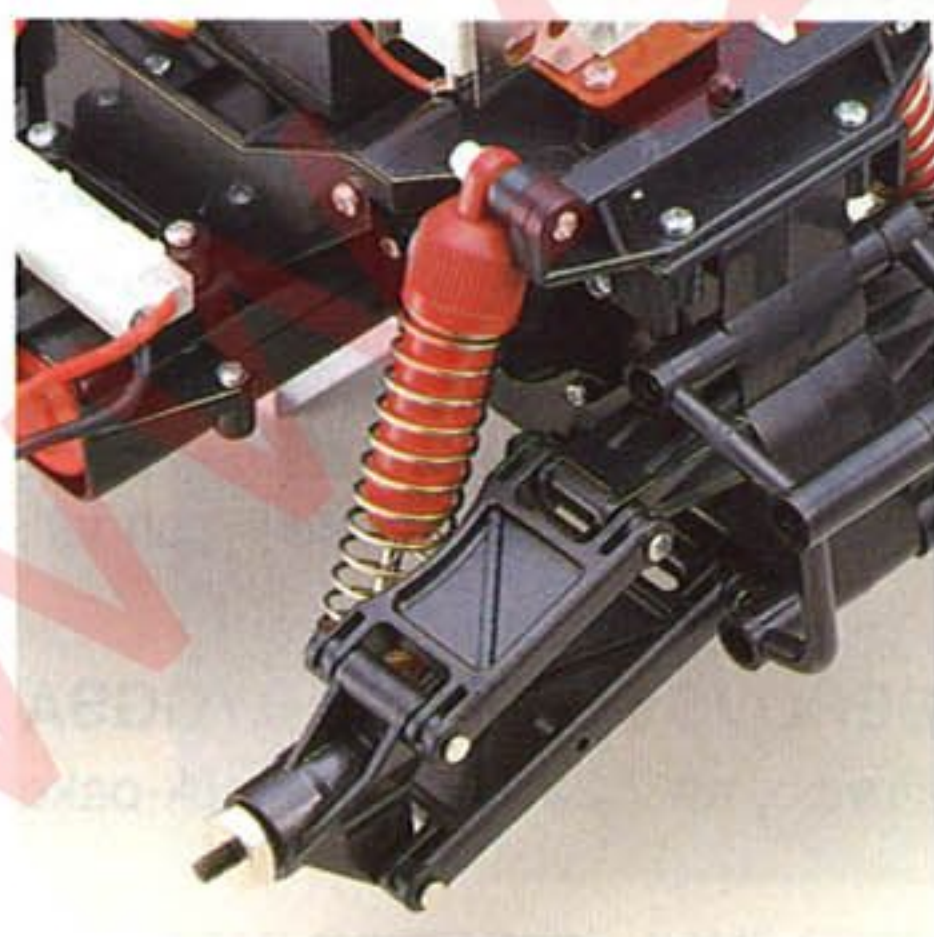
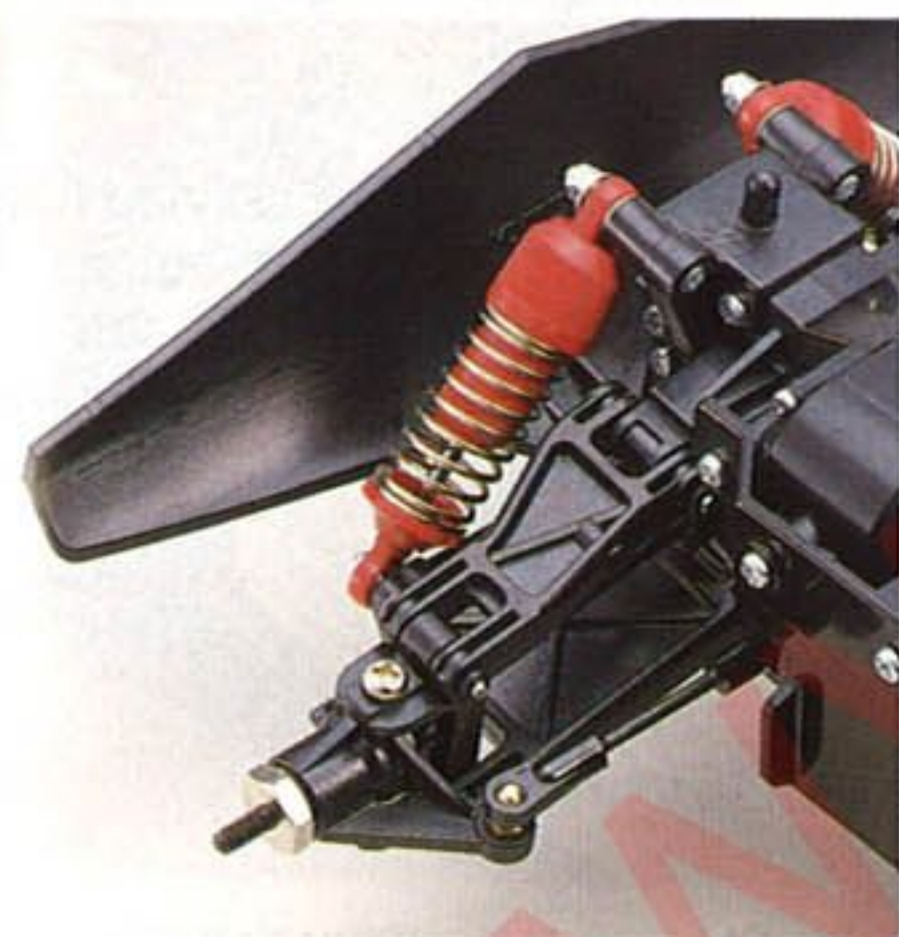
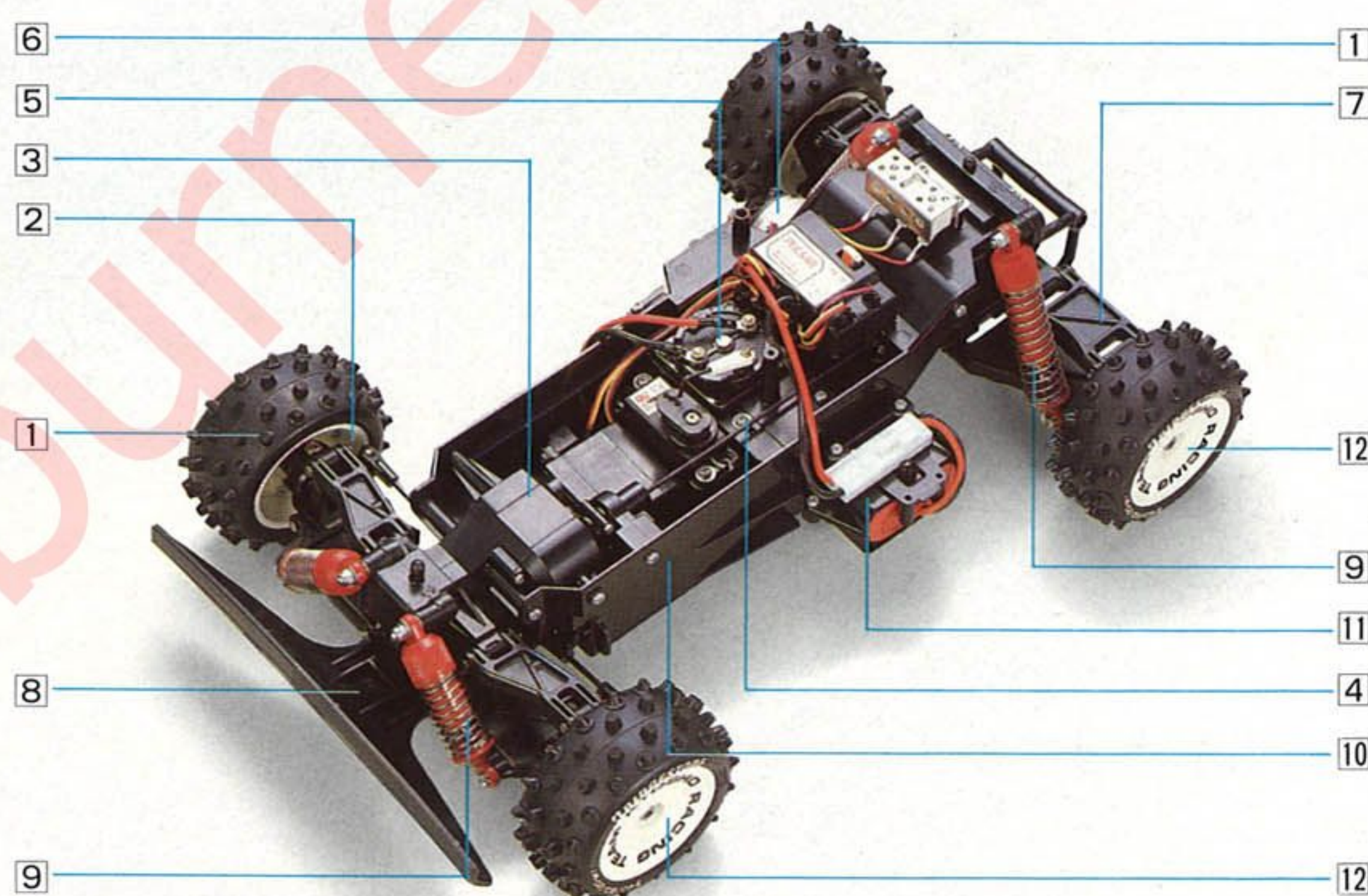

LONG-TRAVEL FRONT SUSPENSION TO SOAK UP REAR SUSPENSION. (SAME FEATURES AS FRONT.) BUMPS. STRONG, MOLDED ABS WISHBONES. FRICTION-TYPE SHOCK ABSORBERS. LIGHT WEIGHT.

STRONG, LIGHT ABS "TUB" TYPE CHASSIS PROTECTS RADIO EQUIPMENT FROM DUST AND SPLASHING.

HIGH-QUALITY, RELIABLE ROTARY SPEED CONTROLLER. SOLID SILVER CONTACTS. 3 FORWARD/1 REVERSE.

De separata hjulupphängningarna är konstruerade för att ge bästa tänkbara styrka och funktion.

Den lättsköta kardanaxeln kopplad till det helkapslade växelhuset gör underhållet enkelt. Superkraftigt nytt fartreglage.



THE ENTRY-LEVEL LEADER!

HIGH PERFORMANCE WITHOUT HIGH COST OR COMPLEXITY. EASY TO ASSEMBLE AND ADJUST. FOUR-WHEEL DRIVE AND FOUR-WHEEL INDEPENDENT SUSPENSION WITH QUALITY KYOSHO OIL-FILLED SHOCK ABSORBERS. MIDSHIPS MOTOR FOR OPTIMUM WEIGHT DISTRIBUTION. POWERFUL LeMANS STOCK 05 MOTOR AND SPEED CONTROLLER INCLUDED IN KIT. STRONG ABS FRONT AND REAR WISHBONES WITH STEEL PIVOT PINS. PROTECTIVE ABS "TUB" TYPE CHASSIS. QUICK-CHANGE BATTERY HOLDER.

REQUIRED FOR OPERATION/RECOMMENDED FOR BEST APPEARANCE (NOT INCLUDED)

●RADIO CONTROL SET (TWO-CHANNEL) ●BATTERY (7.2V-1200mAh OR 7.2V-1700mAh RECHARGEABLE NiCd BATTERY) ●BATTERY CHARGER FOR NiCd BATTERY ●POLYCA COLOR PAINT ●MICRON LINE STRIPING TAPE

Technical Data

①Length/400mm(15.7in) ②Width/244mm(9.6in) ③Height/160mm(6.2in) ④Wheelbase/265mm(10.4in) ⑤Ground Clearance/32mm(1.2in) ⑥Front Track/206mm(8.1in) ⑦Rear Track/206mm(8.1in) ⑧Tires (F)φ85×38mm;(R)φ85×38mm ⑨Total Weight/1650g(3.6lb) ⑩Gear Ratio/7.7:1 ⑪Motor/Le Mans stock 05(Included) ⑫Battery/7.2V-1200mAh(Not included) ⑬Radio/Two-channel(Not included)

KYOSHO 4WD BUGGY TILL LÄGSTA PRIS

Shadow är i grunden samma modell som AeroStreak men den levereras till skillnad från den i byggsats där Du monterar det mesta själv. Faktiskt ett mycket bra sätt att, samtidigt som Du spar en del pengar, lära Dig hur buggyn fungerar i grunden. Det enda som är insparat är att Shadow ej levereras med det nya superfartreglaget. Karossen på Shadow är försedd med en fast monterad rejäl vinge som ger den det rätta tuffa utseendet. Gör som många tusentals andra nöjda nybörjare och välj en Shadow!

DET HÄR BEHÖVS FÖRUTOM BYGGSATSEN

En tvåkanals radio, ett 7.2V/1200mAh ack-paket samt en laddare.

OFF-ROAD RACER *SHADOW 4WD*

ELECTRIC POWERED SPECIAL RACING BUGGY

1:10 SCALE
No. 3181



- 1 LOW-PROFILE, HIGH-TRACTION TIRE.
- 2 ABS DOUBLE-WISHBONE FRONT SUSPENSION.
- 3 FRONT DIFFERENTIAL.
- 4 EFFICIENT SHAFT DRIVE.
- 5 SPEED CONTROLLER (3 FWD/2 REV).
- 6 LeMANS STOCK 05 MOTOR (INCLUDED).
- 7 ABS DOUBLE-WISHBONE REAR SUSPENSION.
- 8 RESILIENT POLYPROPYLENE FRONT BUMPER.
- 9 LARGE-CAPACITY OIL-FILLED SHOCK ABSORBERS.
- 10 PROTECTIVE TUB TYPE CHASSIS.
- 11 PROTECTIVE EASY-LOADING BATTERY HOLDER.
- 12 STRONG, LIGHT POLYPROPYLENE WHEEL.

- 1 Lågprofildäck med kraftiga slitstarka dubbar av gummi.
- 2 Kraftiga dubbla bärmarmar av ABS.
- 3 Växelhus med inbyggt differential (även bak).
- 4 Lättskött kardandrift.
- 5 Fartreglage av kretskortstyp för bästa strömöverföring.
- 6 En råstark LeMans Stock05 motor.
- 7 Kraftiga dubbla bärmarmar av ABS.
- 8 Extremt seg och slagtålig stötfångare.
- 9 Kraftiga oljestötdämpare ger bra väghållning.
- 10 Chassie av lådtype som väl skyddar radio etc.
- 11 Snabbfäste för ack-paketet.
- 12 Fälgar av stark och polypropylen.

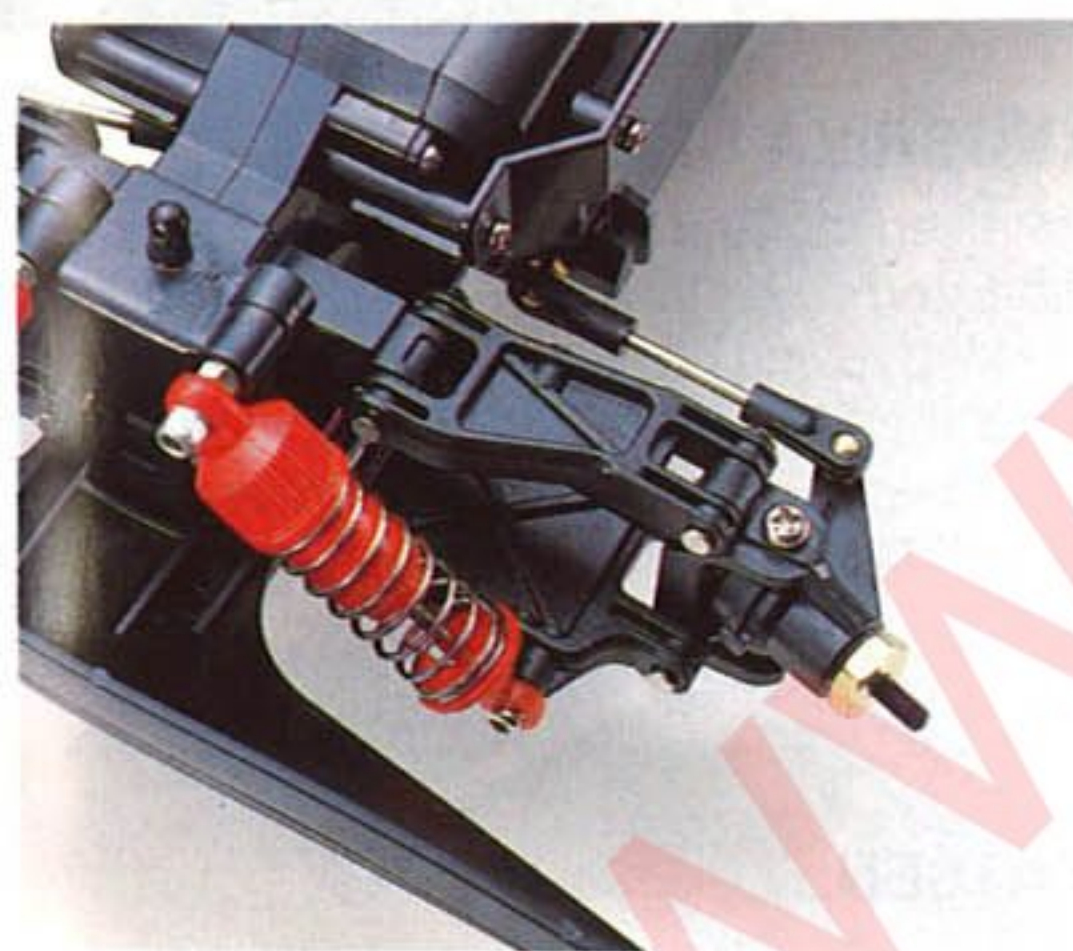
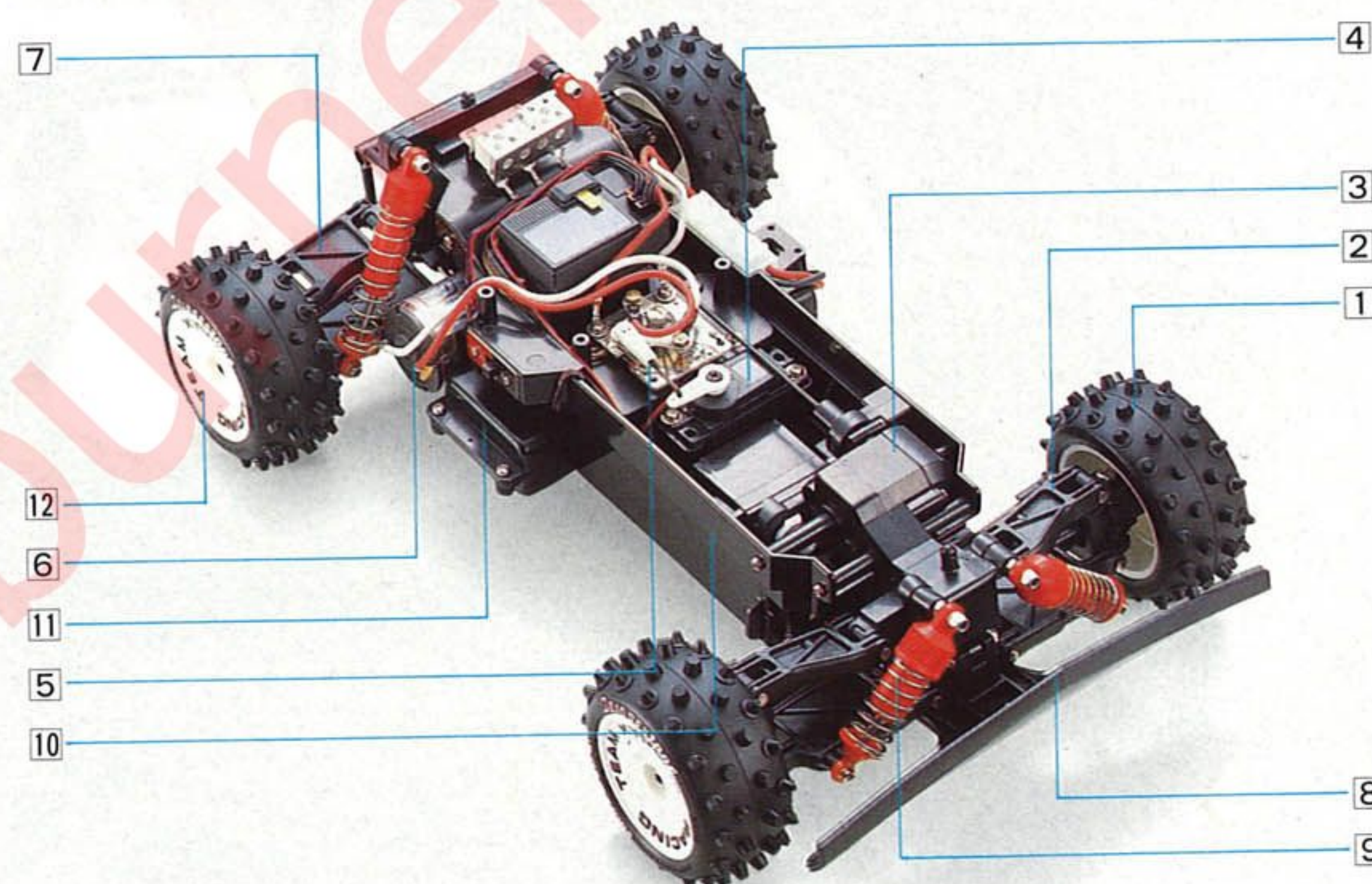

FRONT SUSPENSION. STRONG MOLDED ABS WISHBONES. LIGHT WEIGHT. LONG TRAVEL.

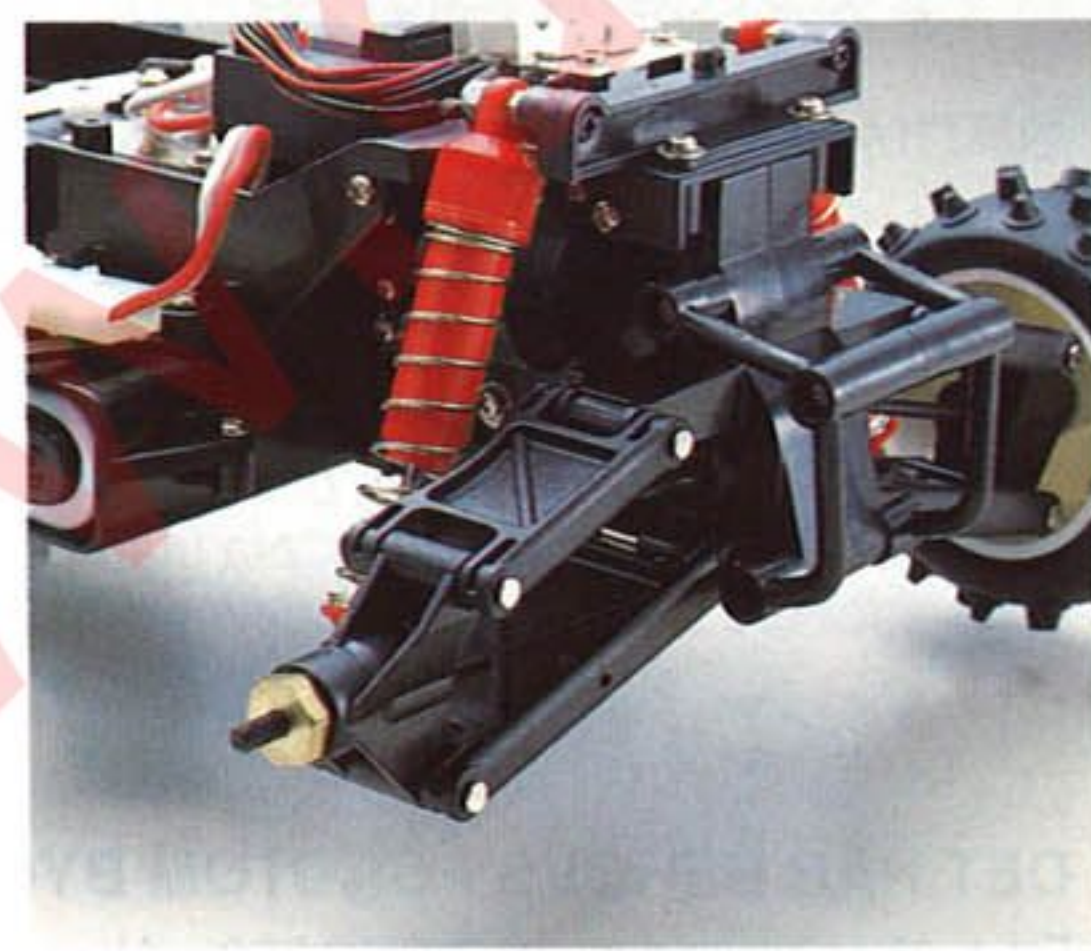

REAR SUSPENSION. SAME GOOD FEATURES AS FRONT. LARGE CAPACITY SHOCK ABSORBERS FRONT / REAR.

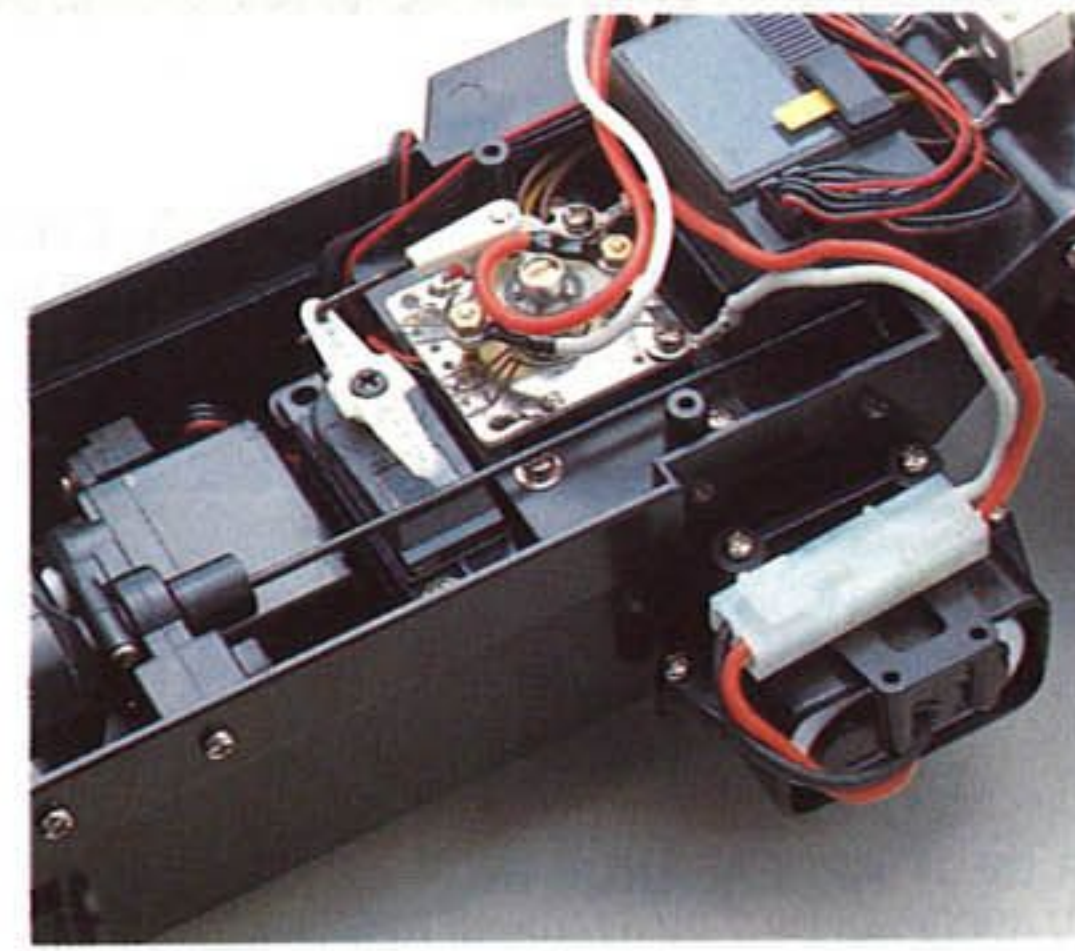

HIGH-CAPACITY SPEED CONTROLLER. THREE FORWARD SPEEDS, TWO REVERSE. SHIELDED RESISTOR.

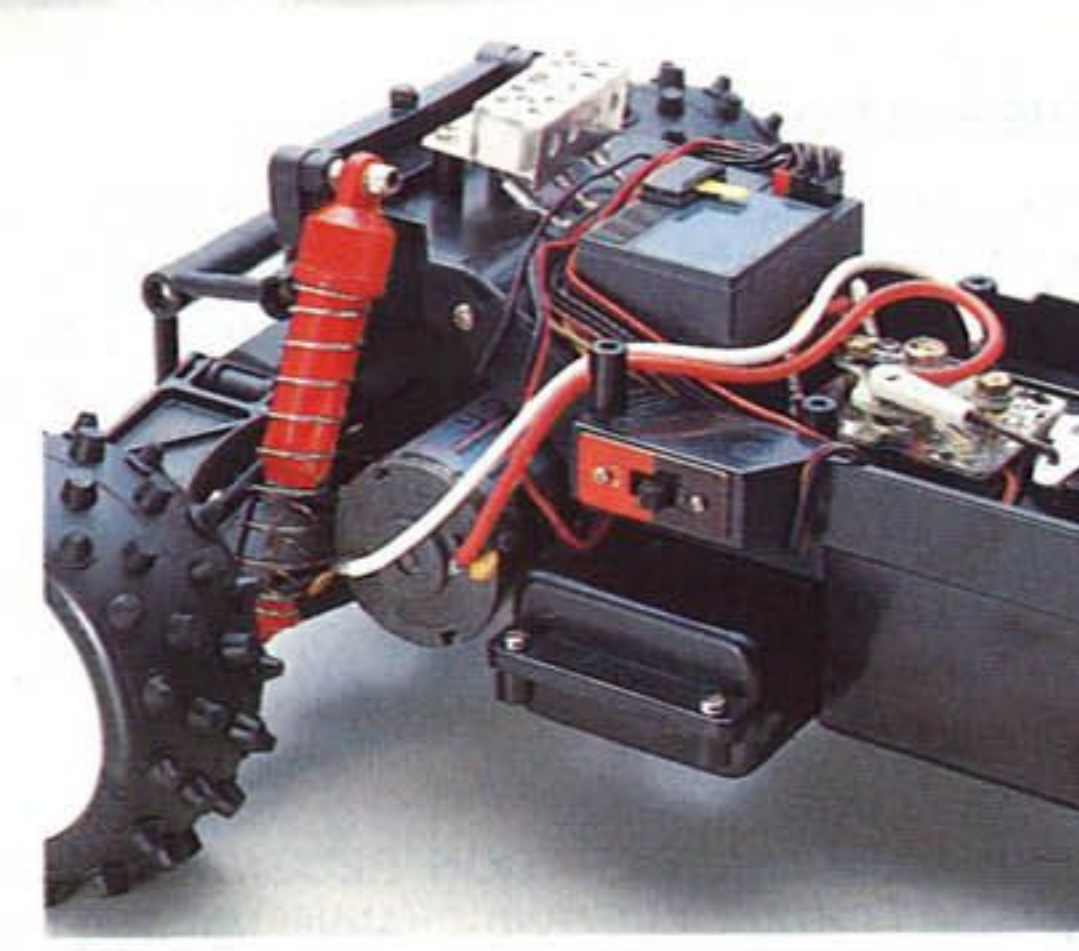

MIDSHIPS-POSITIONED MOTOR AND BATTERY FOR BEST WEIGHT DISTRIBUTION AND HANDLING.

Långa men kraftiga bärmarmar kombinerar styrka med bästa väghållning. Riktiga fungerande oljestötdämpare!

Skyddad installation av motor och fartreglage precis som en nybörjare vill ha det.



THE BEST OPTIMA YET!

THE ORIGINAL OPTIMA WAS THE TOP BUGGY FROM THE START. THE MID IS EVEN BETTER, WITH THE MOTOR AHEAD OF THE REAR WHEELS FOR OPTIMUM BALANCE, AND FOUR-WHEEL DRIVE BY A RELIABLE, LIGHTWEIGHT TOOTHED BELT. THE KIT INCLUDES A POWERFUL LeMANS 240ST MOTOR, A RELIABLE ROTARY SPEED CONTROLLER WITH SILVER CONTACTS, AND 18 BALL BEARINGS. THE MID HAS A STRONG ALLOY ALUMINUM CHASSIS, GLASS-REINFORCED SUSPENSION PARTS, EFFECTIVE OIL-FILLED SHOCK ABSORBERS, AND AN EXTRA-LONG TRAVEL (35MM) SUSPENSION DESIGN TO SOAK UP BUMPS AND STAY ON COURSE.

REQUIRED FOR OPERATION/RECOMMENDED FOR BEST APPEARANCE (NOT INCLUDED)

●RADIO CONTROL SET (TWO-CHANNEL) ●BATTERY (7.2V-1200mAh OR 7.2V-1700mAh RECHARGEABLE NiCd BATTERY) ●CHARGER FOR NiCd BATTERY ●POL YCA COLOR PAINT ●MICRON LINE STRIPING TAPE

Technical Data

①Length/350mm(13.8in) ②Width/240mm(13.4in) ③Height/130mm(5.1in) ④Wheelbase/255mm(10.0in) ⑤Ground Clearance/35mm(1.4in) ⑥Front Track/200mm(7.9in) ⑦Rear Track/202mm(7.9in) ⑧Tires (F)φ85×37mm;(R)φ85×37mm; ⑨Total Weight/1600g(3.5lb) ⑩Gear Ratio/9.78:1 ⑪Motor/Le Mans 240ST(Included) ⑫Battery/7.2V-1200mAh(Not included) ⑬Radio/Two-channel(Not included)

OPTIMA - VÄRLDENS MEST FRAMGÅNGSRIKA BUGGY

Ja, ända sedan den första modellen i Optima familjen mötte dagens ljus för fyra år sedan har den lämnat det mesta bakom sig i resultatlistorna. Naturligtvis har den hela tiden fortsatt att utvecklas. Den nuvarande modellen - MidOptima - är regerande Europamästare. Men också regerande Svensk mästare! MidOptima finns i ett flertal olika modeller för att täcka alla behov - allt från den extrema tävlingsbilen till den perfekta grusracern för Dig som bara nöjer Dig med det bästa utan att för den skull sikta just på tävlingsidan! Det här uppslaget presenterar basmodellen MidOptima.

DET HÄR BEHÖVS FÖRUTOM BYGGSATSEN

En tvåkanals radio, ett 7.2V/1200mAh ack-paket samt en laddare.

4WD OFF-ROAD RACER OPTIMA MID

ELECTRIC POWERED SPECIAL RACING BUGGY

1:10 SCALE

No. 3135



- 1 PRESSURE-TYPE OIL-FILLED SHOCK ABSORBER (x4).
- 2 FRONT DIFFERENTIAL. METAL GEARS.
- 3 FRP UPPER CHASSIS PLATE WITH BELT SHIELD (TOTAL ENCLOSURE).
- 4 REINFORCED MATERIAL TOOTHED DRIVE BELT.
- 5 AERODYNAMIC ADJUSTABLE WING.
- 6 LOW-PROFILE TIRES WITH HIGH-GRIP SPIKE TREAD.
- 7 RACING-TYPE FRONT BUMPER.
- 8 WISHBONE PARALLEL ARM FRONT SUSPENSION. GLASS FILLED EX66 NYLON.
- 9 ALLOY ALUMINUM CHASSIS PLATE.
- 10 SPEED CONTROLLER (3 SPEEDS: INCLUDED IN KIT)
- 11 BATTERY. (7.2V-1200mAh NiCd; NOT INCLUDED.)
- 12 LONG-TRAVEL WISHBONE PARALLEL ARM REAR SUSPENSION.
- 13 LIGHTWEIGHT NYLON WHEEL.

- 1 Tryckoljestötdämpare (Guld) runt om.
- 2 Helkapslat främre diffhus med tandremsskiva.
- 3 Radioplatta av glasepoxi, kanal för tandremmen.
- 4 Armerad extremt tålig tandrem.
- 5 Justerbar aerodynamisk ving.
- 6 Lågprofildäck med mjuka gummidubbar för maximal grepp.
- 7 Liten lätt racingstötfångare.
- 8 Extremt långa bärramar av en perfekt blandning av nylon och glas.
- 9 Chassieplatta av aluminium i flygkvalitet.
- 10 Trestegs fartreglage med silverkontakter.
- 11 Ack-paketet är monterat i snabbfäste.
- 12 Extremt långa bärramar precis som fram.
- 13 Lätta och mycket starka fälgar av nylon.

Byggsatsen innehåller totalt hela 18 st kullager!

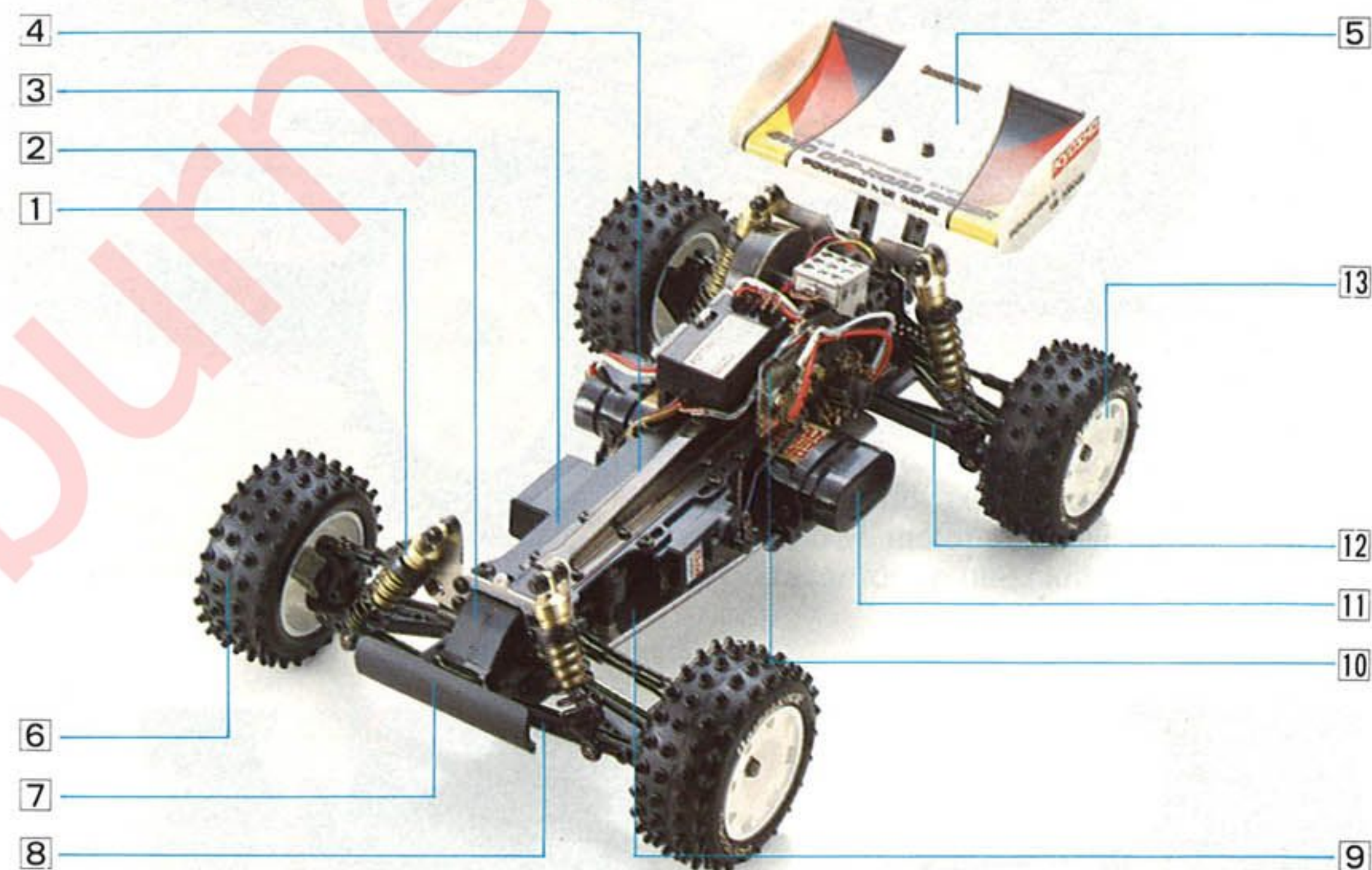

EXTRA-LENGTH WISHBONE ARM FRONT SUSPENSION FOR LONG TRAVEL. REAR SUSPENSION (SAME FEATURES AS FRONT). BOTH F R HAVE PRESSURE SHOCK AND ADJUSTABLE GEOMETRY.

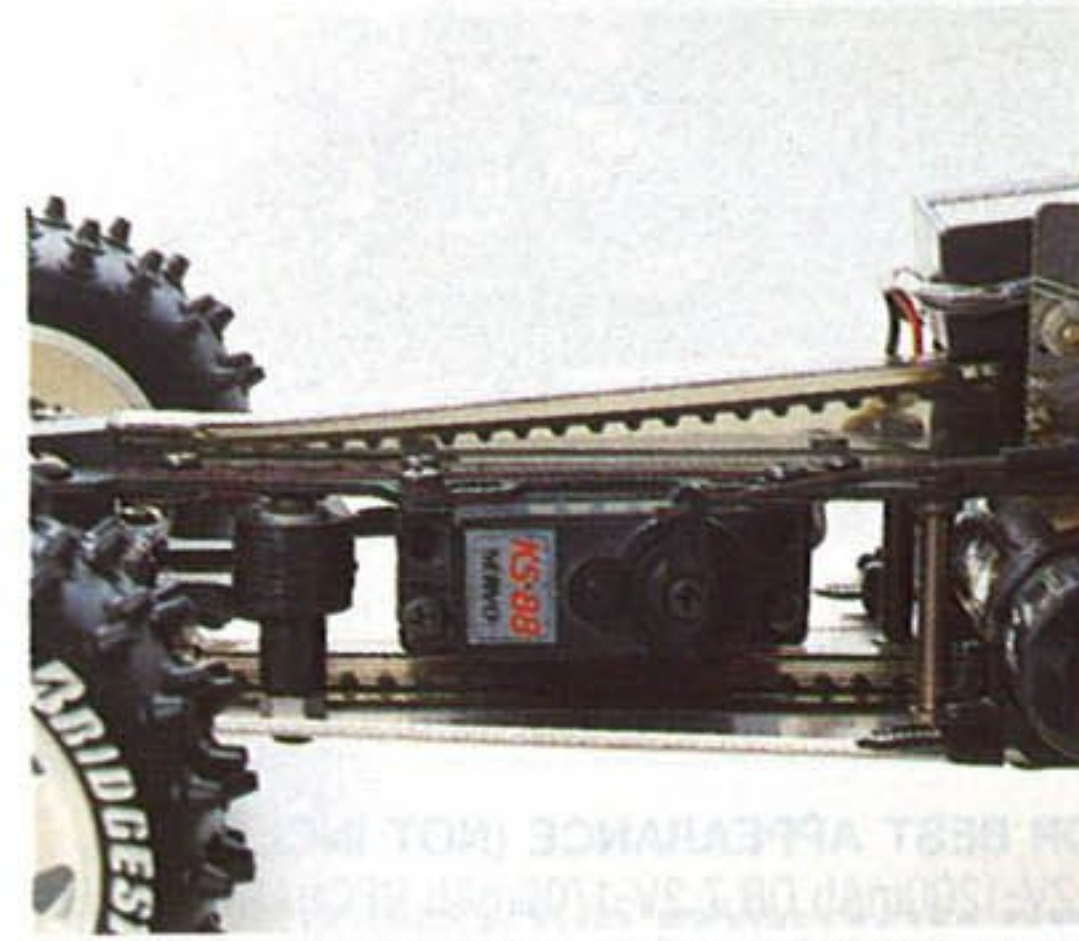
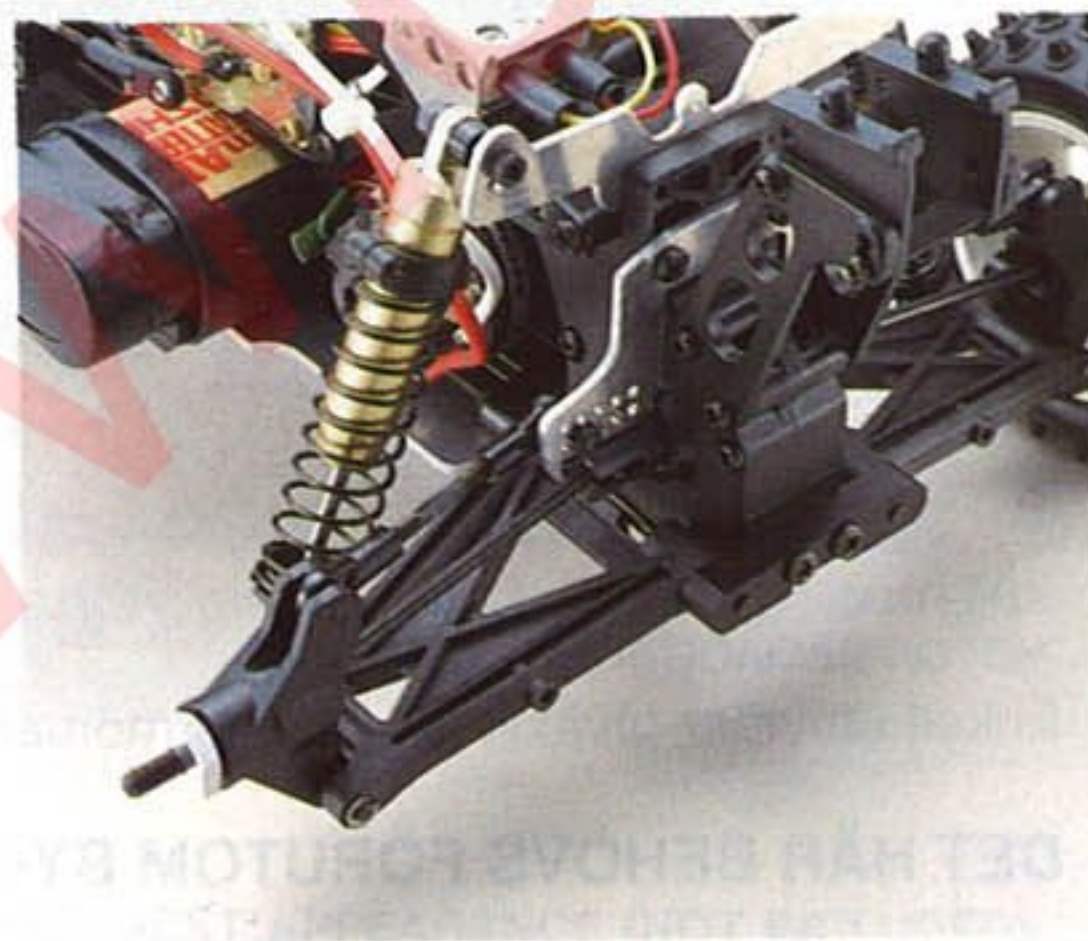

TOOTHED DRIVE BELT. LIGHT, STRONG, RELIABLE. REINFORCED MATERIAL TO PREVENT STRETCHING.

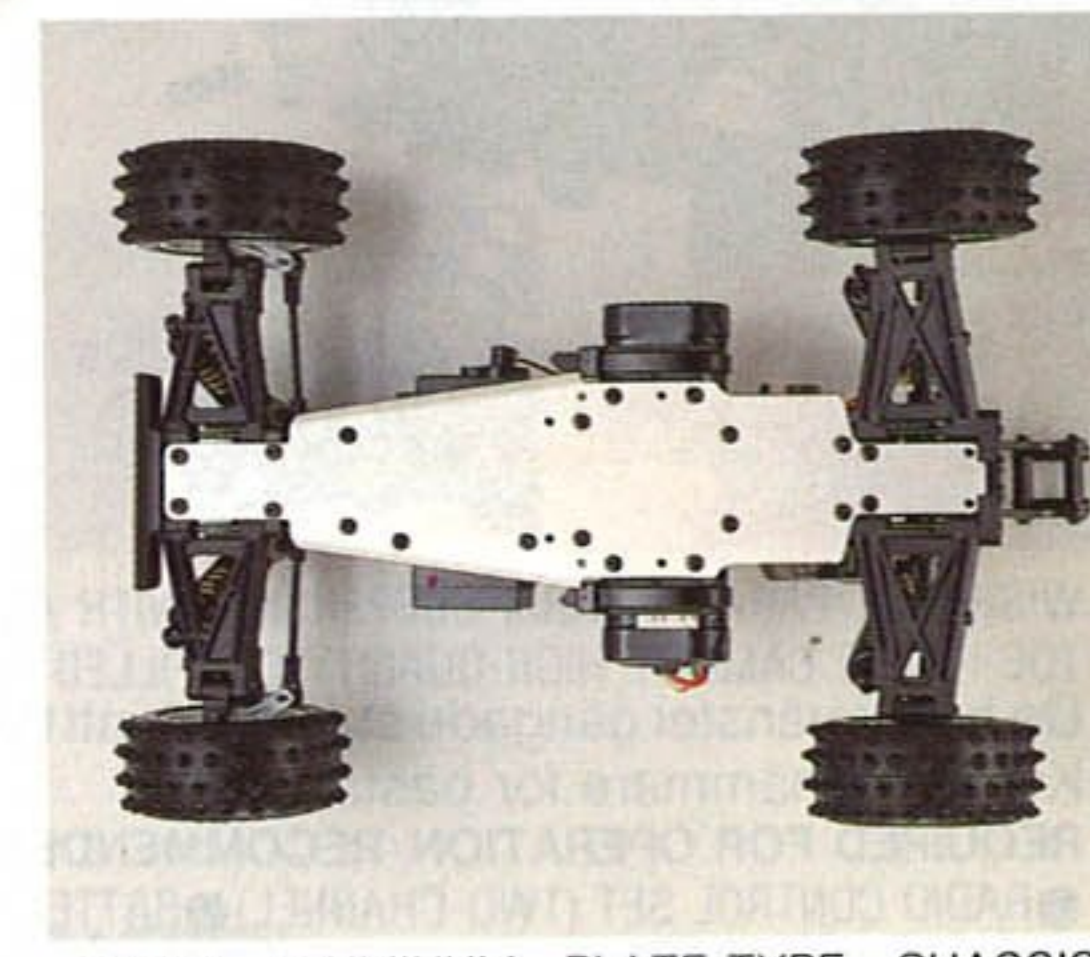

ALLOY ALUMINUM PLATE-TYPE CHASSIS. STRONG. LIGHT.

Långa bärramar, rätt grundgeometri och perfekta justeringsmöjligheter är den största "hemligheten" bakom framgångarna.

Kapslad utväxling, nya tryckoljestötdämpare och ett chassie i pläterad flygaluminium som är förberett för de nya "saddle-pack" ack-paketerna.

4WD OFF-ROAD RACER *TURBO OPTIMA MID*

ELECTRIC POWERED RACING BUGGY

1:10 SCALE

No. 3136



THE CUSTOM BUILDER'S OPTIMA!

THE *TURBO OPTIMA MID* HAS ALL THE GREAT FEATURES OF THE *MID*, BUT ALLOWS YOU TO SELECT THE ELECTRONIC SPEED CONTROLLER AND MOTOR OF YOUR CHOICE. (OPTIMUM MOTORS ARE *LeMANS 240* AND *360* SERIES.) THE *TURBO* ALSO HAS ANTI-SWAY BARS FRONT AND REAR, SIMPLIFIED ADJUSTMENT OF TOE-IN AND CAMBER, STRONG, LIGHT GLASS/POLYESTER SHOCK TOWERS, AND FLUSH UNDER-CHASSIS SCREWS, PLUS TWO *OPTION* HOUSE PREMIUM-QUALITY COMPONENTS, UNIVERSAL-JOINTED SWING SHAFTS. AND A TORQUE LIMITER THAT PREVENTS MOTOR DAMAGE IF THE WHEELS JAM. IT CONTINUES ALL THE USUAL *MID* FEATURES, SUCH AS LONG-TRAVEL SUSPENSION WITH EFFECTIVE OIL-FILLED SHOCK ABSORBERS ON ALL FOUR WHEELS, FOUR-WHEEL DRIVE BY EFFICIENT, LIGHT-WEIGHT TOOTHED BELT, TWO DIFFS, AND 18 BALL BEARINGS.

TURBO OPTIMA MID

Det här är en racigare version av MidOptima. Den levereras precis som MidOptima helt kullagrad men utan motor och fartreglage. Motor väljer Du själv liksom lämpligt elektroniskt fartreglage. All den här "extratrustningen" är standard på en Turbo: extra kraftigt chassie av "17S" aluminium, alla stag snabbjusterbara, krängningshämmare, stötdämparfästen i glasepoxi och extra förstärkningar!

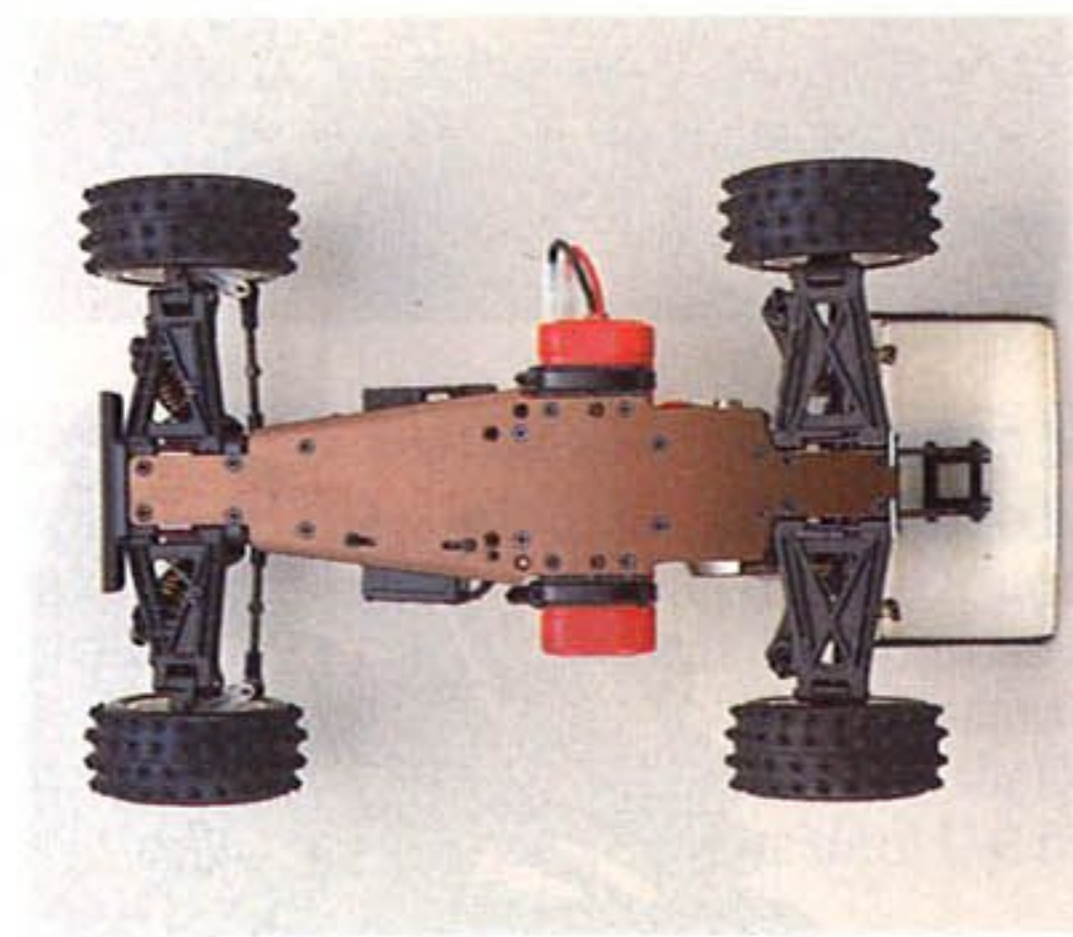
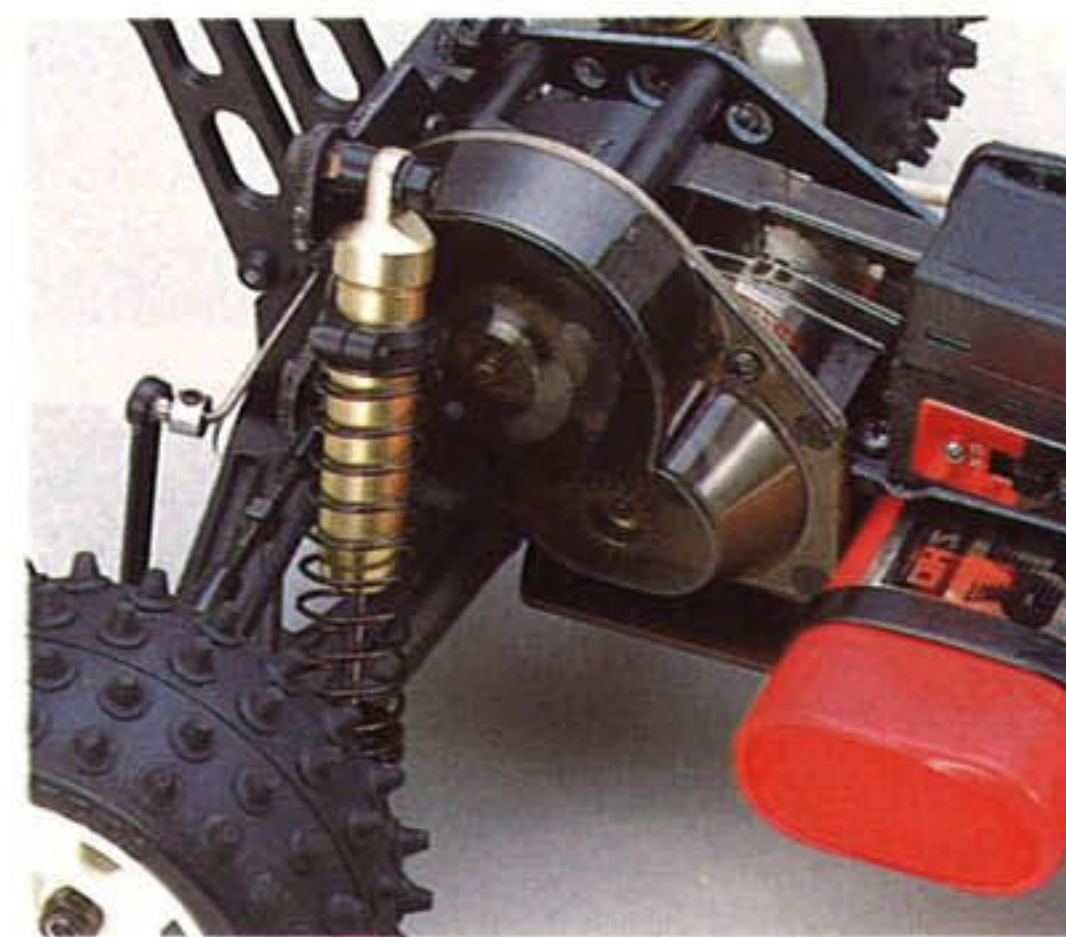
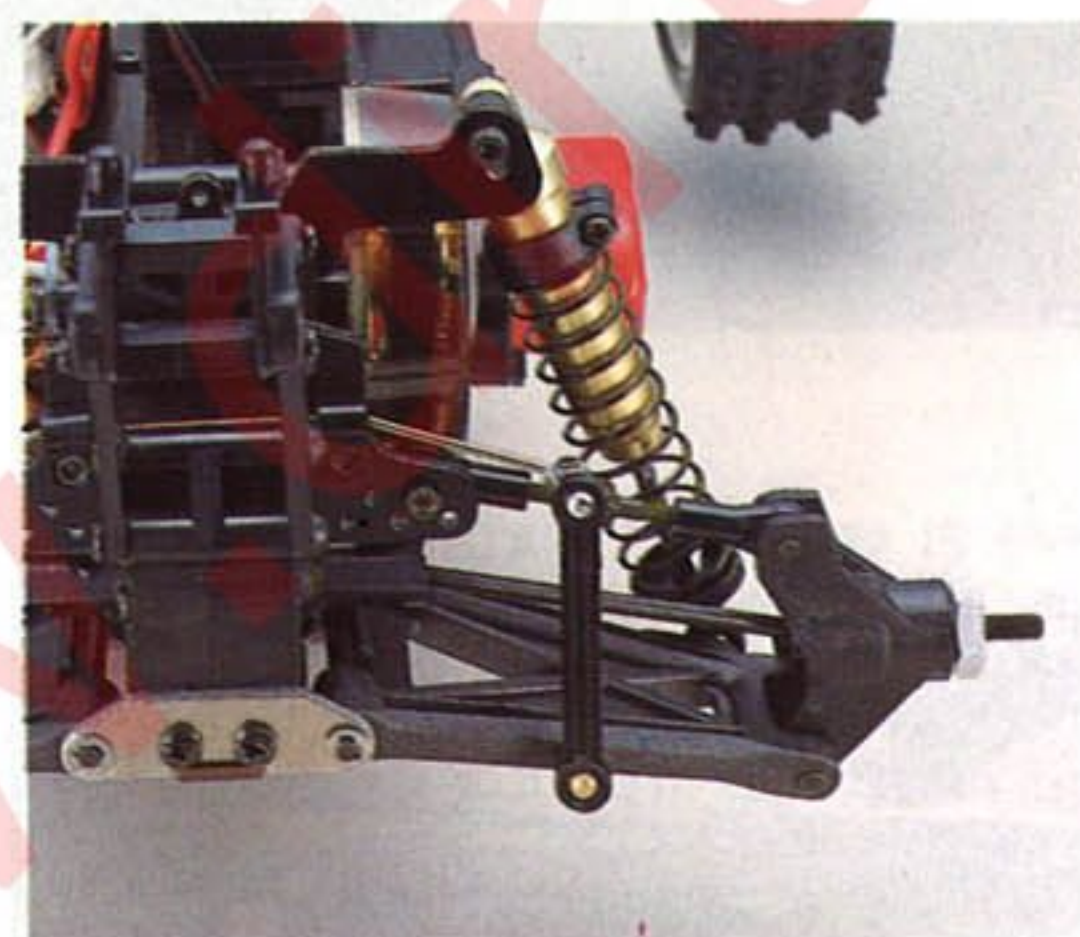
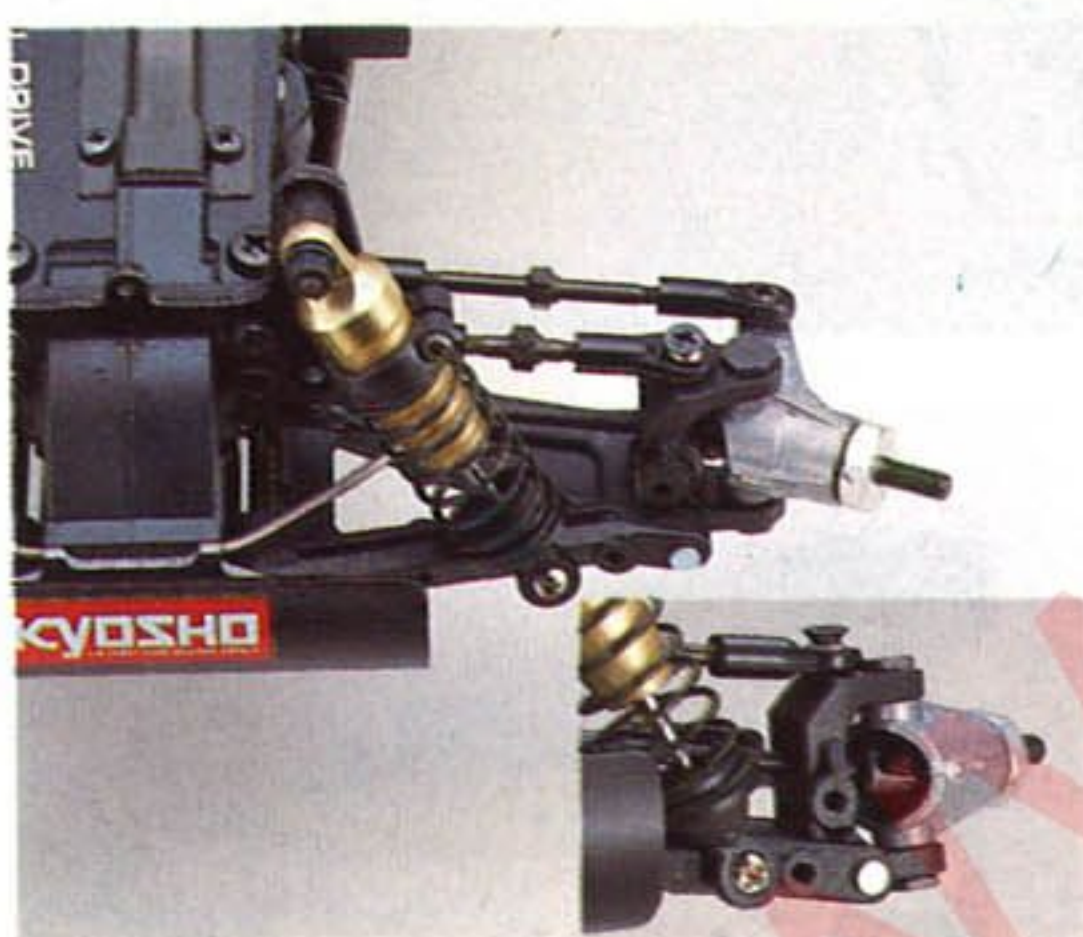

WISHBONE/PARALLEL-ARM SUSPENSION WITH ANTI-SWAY BARS FRONT/REAR. EASY ADJUSTMENT OF TOE-IN AND CAMBER. HIGH-QUALITY OIL-FILLED SHOCKS. UNIVERSAL-JOINT HALFSHAFTS (FRONT). De höger/vänster gängade stagen gör att toe-in och camber justeras på några få sekunder. Krängninghämmare för bästa balans!

REQUIRED FOR OPERATION/RECOMMENDED FOR BEST APPEARANCE (NOT INCLUDED)

●RADIO CONTROL SET (TWO-CHANNEL) ●BATTERY (7.2V-1200mAh OR 7.2V-1700mAh RECHARGEABLE NiCd BATTERY) ●CHARGER FOR NiCd BATTERY ●POLYCA COLOR PAINT ●MICRON LINE STRIPING TAPE

Technical Data

①Length/350mm(13.8in) ②Width/240mm(13.4in) ③Height/130mm(5.1in) ④Wheelbase/255mm(10.0in) ⑤Ground Clearance/35mm(1.4in) ⑥Front Track/200mm(7.9in) ⑦Rear Track/202mm(7.9in) ⑧Tires (F)φ85×37mm;(R)φ85×37mm ⑨Total Weight/1600g(3.5lb) ⑩Gear Ratio/9.78:1 ⑪Motor/Le Mans 240/360type(Not included) ⑫Battery/7.2V-1200mAh(Not included) ⑬Radio/Two channel(Not included)

INTERNAL TORQUE LIMITER PREVENTS MOTOR DAMAGE IF WHEELS JAM.

Enkelt utbytbar utväxling, inbyggd momentbegränsare och 2.3 mm aluminiumchassie.

2.3MM ALLOY ALUMINUM PLATE-TYPE CHASSIS. STRONG. LIGHT.

DET HÄR BEHÖVS FÖRUTOM BYGGSATSEN

En tvåkanals radio med elektroniskt fartreglage, en LeMans motor, ett 7.2V/1200mAh ack-paket samt laddare.

4WD OFF-ROAD RACER *TURBO OPTIMA MID SE*

ELECTRIC POWERED RACING BUGGY

1:10 SCALE
No. 3136H



- ① OIL-FILLED SHOCK ABSORBERS (× 4).
- ② FRONT DIFFERENTIAL (METAL GEARS).
- ③ FRP REAR SHOCK-ABSORBER MOUNT.
- ④ REINFORCED TOOTHED DRIVE BELT.
- ⑤ AERODYNAMIC ADJUSTABLE WING.
- ⑥ LOW-PROFILE TIRES WITH HIGH-GRIP SPIKE TREAD.
- ⑦ KYOSHO ROTARY SPEED CONTROLLER.
- ⑧ WISHBONE/PARALLEL ARM FRONT SUSPENSION. GLASS-FILLED EX66 NYLON.
- ⑨ ALLOY ALUMINUM CHASSIS PLATE.
- ⑩ ANTI-SWAY BARS FRONT/REAR.
- ⑪ BATTERY. (7.2V-1200mAh NiCd; NOT INCLUDED)
- ⑫ LONG-TRAVEL WISHBONE/PARALLEL ARM REAR SUSPENSION.
- ⑬ METALIZED NYLON WHEEL.

PERFEKT GRUSRACER

Det här är en topputrustad "lyxversion" i MidOptima serien och den heter TurboOptimaMidSE. Det handlar om den perfekta grusracern för Dig som kanske inte i första hand siktar på tävling - bara på perfektion! Superutrustad med Platina stötdämpare, nya "rotary" fartreglaget, krängningshämmare, kromade fälgar, kuldifferentialer, främre drivaxlar med kardanknut, LeMans 240ST motor och mycket mer. En buggy racer för de mest kräsna!

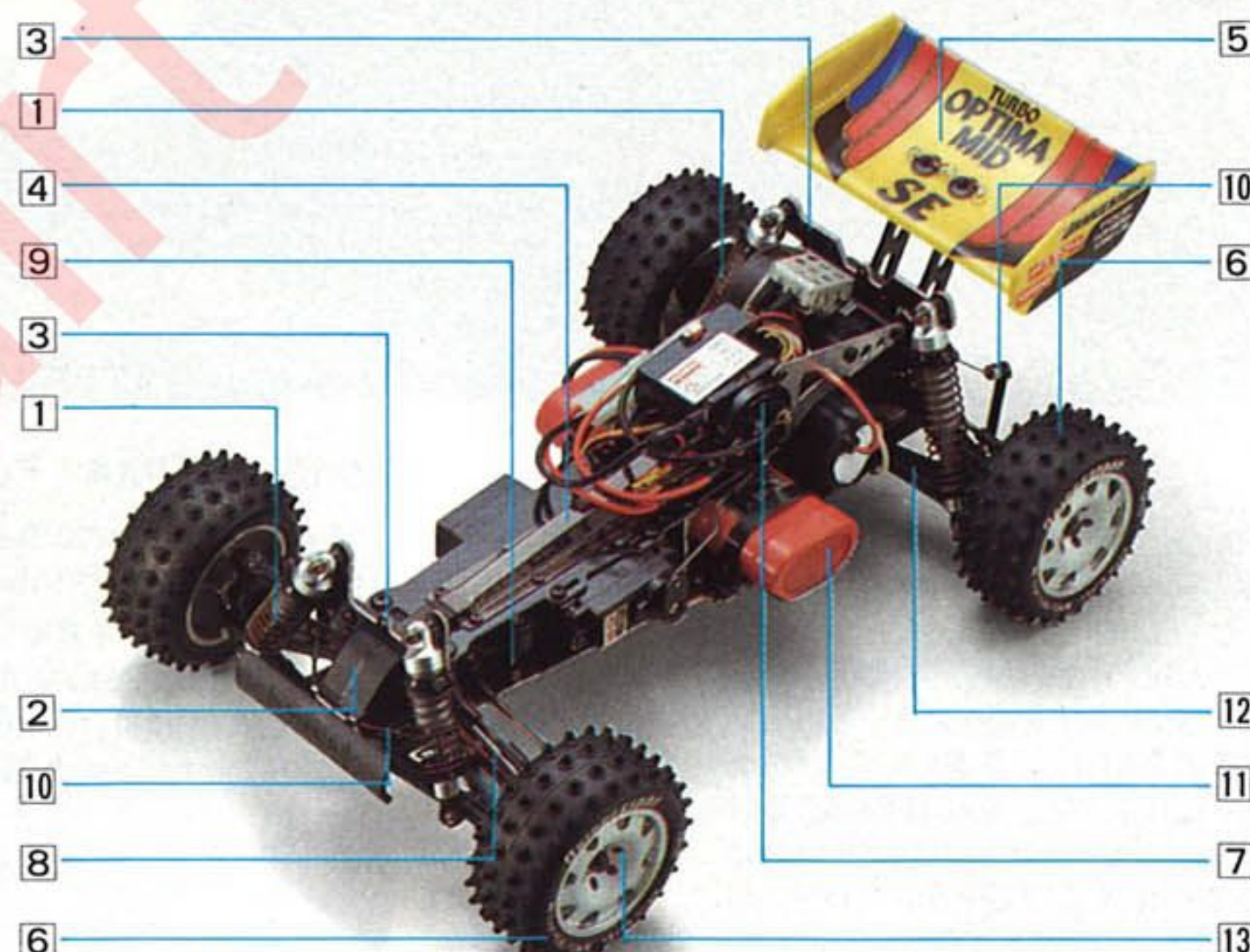
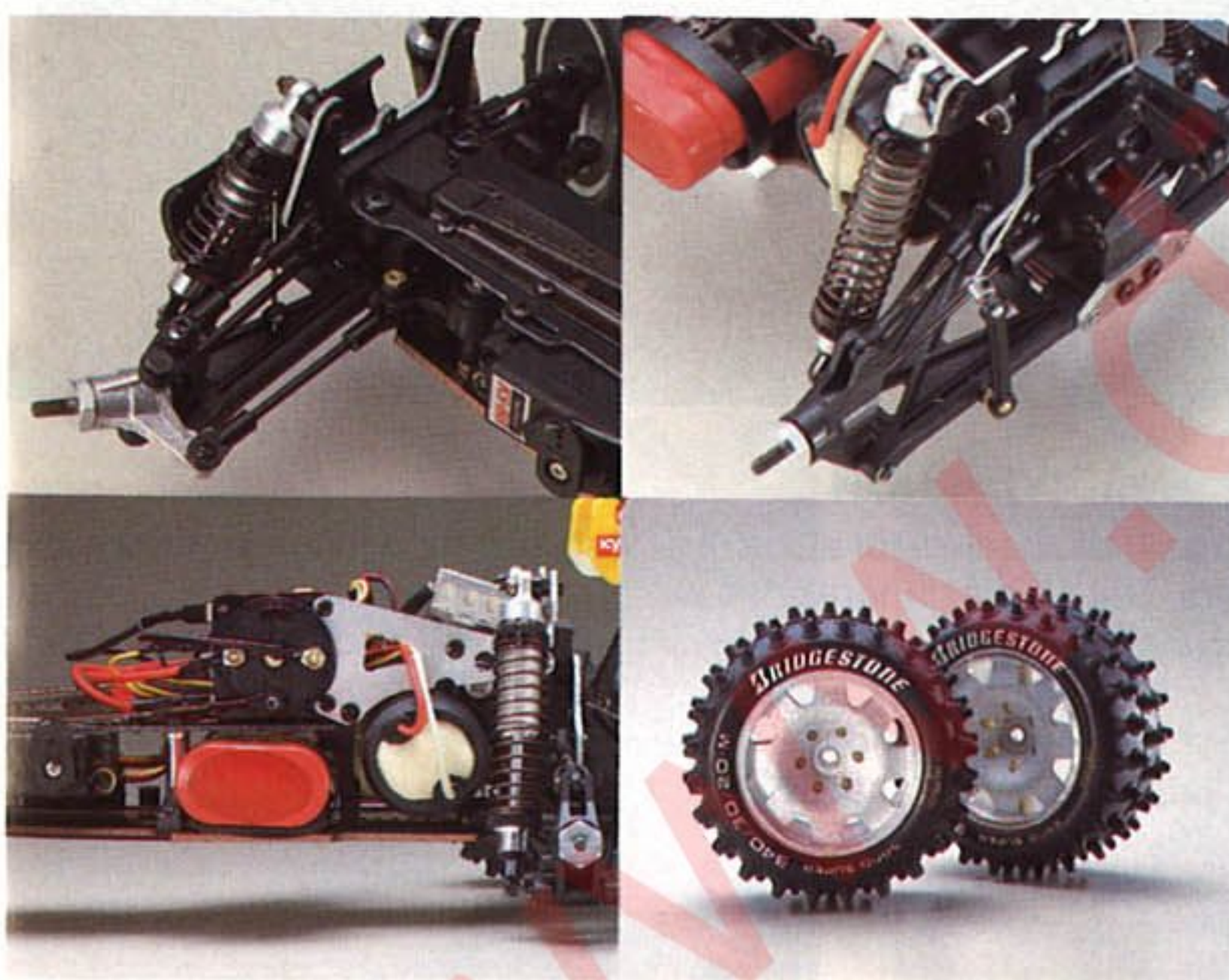

REQUIRED FOR OPERATION/RECOMMENDED FOR BEST APPEARANCE (NOT INCLUDED)

● RADIO CONTROL SET (TWO-CHANNEL) ● BATTERY (7.2V-1200mAh OR 7.2V-1700mAh RECHARGEABLE NiCd BATTERY) ● CHARGER FOR NiCd BATTERY ● POLYCA COLOR PAINT ● MICRON LINE STRIPING TAPE

Technical Data

① Length/370mm (14.6") ② Width/240mm (9.4") ③ Height/130mm (5.2") ④ Wheelbase/255mm (10.0") ⑤ Ground clearance/35mm (1.4") ⑥ Front track/200mm (7.9") ⑦ Rear track/202mm (7.9") ⑧ Tires (F/R)/φ85×30mm ⑨ Weight (track-ready)/1600g (3lb 8oz) ⑩ Motor (included)/LeMans 240ST ⑪ Battery (not included)/7.2V-1200mAh NiCd ("stick" type) ⑫ Radio control set (not included)/Two-channel

DET HÄR BEHÖVS FÖRUTOM BYGGSATSEN

En tvåkanals radio, ett 7.2V/1200mAh ack-paket samt en laddare.



THE LONG-WHEELBASE PERFORMER!

FOR THE FASTEST LAPS ON COURSES WITH MANY STRAIGHTS. HAS ALL THE IMPORTANT FEATURES OF THE LIMITED-PRODUCTION *TURBO OPTIMA MID SPECIAL*. FEATURES THE MAXIMUM OF PERFORMANCE WITH A MINIMUM INVESTMENT. ALL-INDEPENDENT LONG-TRAVEL WISHBONE/ARM SUSPENSION WITH GLASS-REINFORCED COMPONENTS. HIGH-PERFORMANCE *PRESSURE* OIL-FILLED SHOCK ABSORBERS. RIGID 17S ALLOY ALUMINUM CHASSIS. STRONG, LIGHT FRP SHOCK TOWERS AND RADIO PLATE. POWERFUL *LeMANS 240ST* MOTOR (INCLUDED) DRIVES THROUGH A TORQUE-PROTECTED MAIN GEAR AND LIGHT, EFFICIENT TOOTHED BELT TO THE FRONT AND REAR GEAR-TYPE DIFFERENTIALS (FACTORY ASSEMBLED, WITH OUTPUT SHAFT BALL BEARINGS). *ROTARY* SPEED CONTROLLER (3 FWD/1 REV) HAS SILVER CONTACTS FOR LONG LIFE (INCLUDED). HAS MOUNTS FOR "SADDLE PACK" AND "STICK" TYPE BATTERIES (NOT INCLUDED). FULL PROTECTIVE BELLY PAN AND STYLISH, RACY BODY. MANY OPTIONAL COMPETITION PARTS.

REQUIRED FOR OPERATION/RECOMMENDED FOR BEST APPEARANCE (NOT INCLUDED)

●RADIO CONTROL SET (TWO-CHANNEL) ●BATTERY (7.2V-1200mAh OR 7.2V-1700mAh RECHARGEABLE NiCd BATTERY) ●CHARGER FOR NiCd BATTERY ●POLYCA COLOR PAINT ●MICRON LINE STRIPING TAPE

Technical data

①Length/370mm (14.6") ②Width/240mm (9.4") ③Height/130mm (5.2") ④Wheelbase/273mm (10.7") ⑤Ground clearance/35mm (1.4") ⑥Front track/207mm (8.1") ⑦Rear track/202mm (7.9") ⑧Tires (F/R)/φ85×37mm ⑨Weight (track-ready)/1600g (3 lb 56.5oz) ⑩Motor (included)/LeMans 240ST ⑪Battery (not included)/7.2V-1200/1700mAh NiCd ("stick" type) ⑫Radio control set (not included)/Two-channel

MID OPTIMA I FÖRLÄNGD VERSION

MidOptimaCustom är utvecklad speciellt för att på tävlingsbanor med långa snabba kurvor ge en lugn och stabil gång. Det 18 mm längre chassiet och en rad andra detaljer gör detta till en av årets mest intressanta racing nyheter som t ex kaross med "underbalja" som skyddar chassie och radioinstallation från grus och lersprut, släta turbinfälgar, nya "rotary" fartreglaget, fyra kullager och mycket annat. Den levereras komplett med en LeMans 240ST motor och till ett pris som är förvånansvärt lågt för "det nyaste inom 4WD racing"!

DET HÄR BEHÖVS FÖRUTOM BYGGSATSEN

En tvåkanals radio, ett 7.2V/1200mAh ack-paket samt en laddare.

4WD OFF-ROAD RACER OPTIMA MID CUSTOM

ELECTRIC POWERED RACING BUGGY

1:10 SCALE
No. 3139

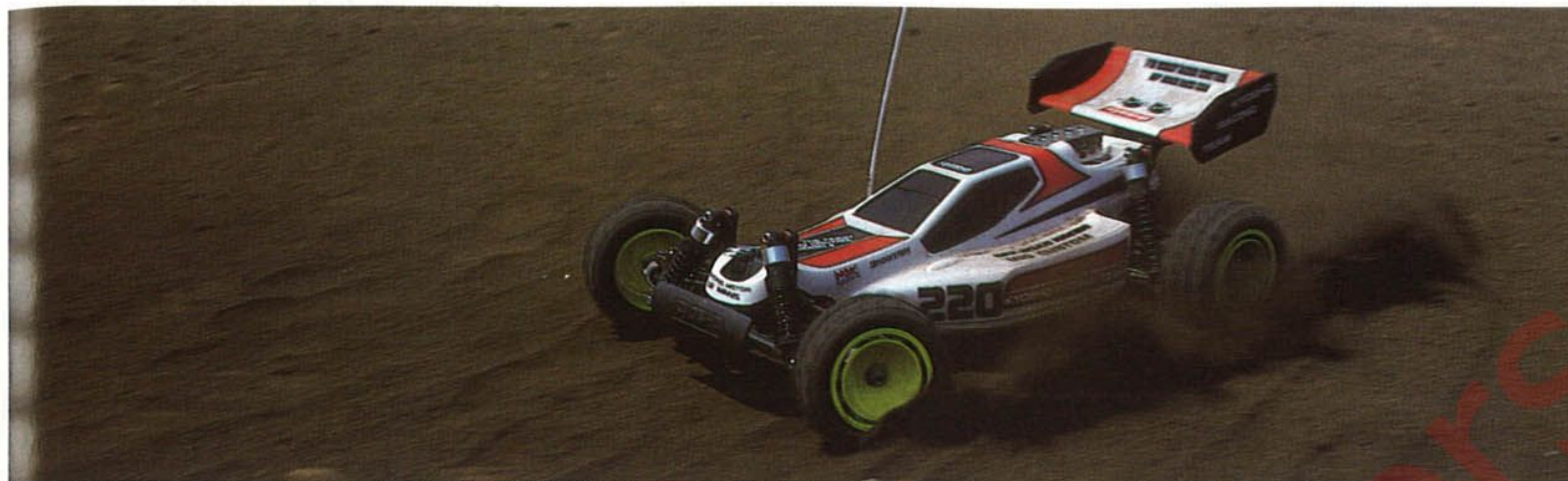

- 1 PRESSURE-TYPE OIL-FILLED SHOCK ABSORBER (x4).
- 2 FRONT DIFFERENTIAL. METAL GEARS.
- 3 FRP UPPER CHASSIS PLATE WITH BELT SHIELD (TOTALLY ENCLOSED).
- 4 TOOTHED DRIVE BELT (REINFORCED).
- 5 AERODYNAMIC ADJUSTABLE WING.
- 6 LOW-PROFILE TIRES WITH HIGH-GRIP SPIKE TREAD.
- 7 RACING-TYPE FRONT BUMPER.
- 8 WISHBONE/PARALLEL ARM FRONT SUSPENSION. GLASS FILLED EX66 NYLON.
- 9 ALLOY ALUMINUM CHASSIS PLATE.
- 10 HIGH-QUALITY ROTARY SPEED CONTROLLER (3 FWD/1 REV)
- 11 BATTERY. (7.2V-1200mAh NiCd; NOT INCLUDED.)
- 12 LONG-TRAVEL WISHBONE/PARALLEL ARM REAR SUSPENSION.
- 13 LIGHTWEIGHT NYLON WHEEL.

- 1 Differential i kapslat växelhuss.
- 2 Bärarmar av glasfylld nylon av högsta klass.
- 3 Smala nabbade framdäck för bästa grepp men minimal friktion.
- 4 Breda nabbade mjuka bakdäck för maximal grepp.
- 5 Skyddande "underbalja" av lexan.
- 6 Nya tryckoljestötdämpare.
- 7 Starka och lätta turbin fälgar av nylon.
- 8 Nya "rotary" fartreglaget.
- 9 Fäste för valfritt standard eller "saddle-pack" ack-paket.
- 10 Vass och stark LeMans 240ST motor ingår.
- 11 Pläterat chassie av aluminium i flygkvalitet.
- 12 Differential i kapslat växelhuss.
- 13 Tandrem för bästa kraftöverföring (kapslad).
- 14 Kraftigt fartregleringsmotstånd.



EXTRA-LENGTH WISHBONE ARM FRONT SUSPENSION FOR LONG TRAVEL. REAR SUSPENSION (SAME FEATURES AS FRONT). BOTH F/R HAVE PRESSURE SHOCK AND ADJUSTABLE GEOMETRY.

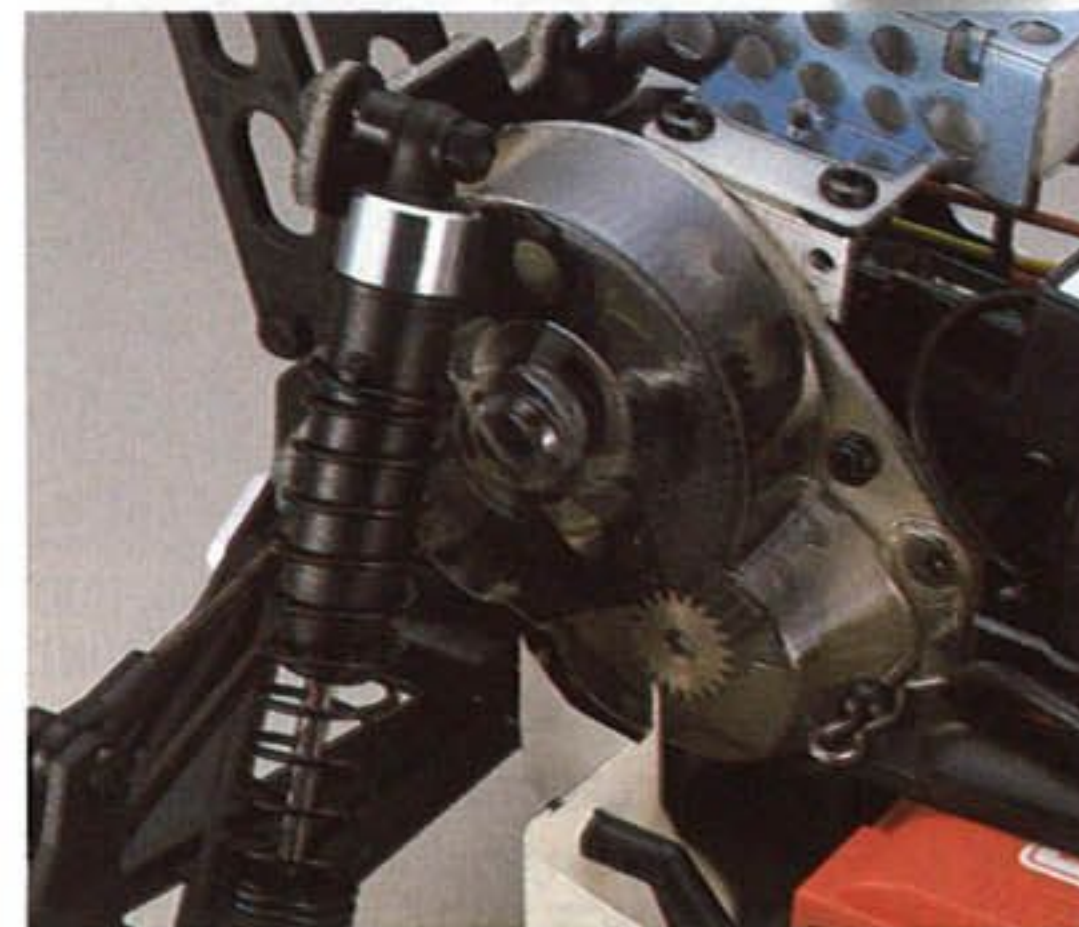
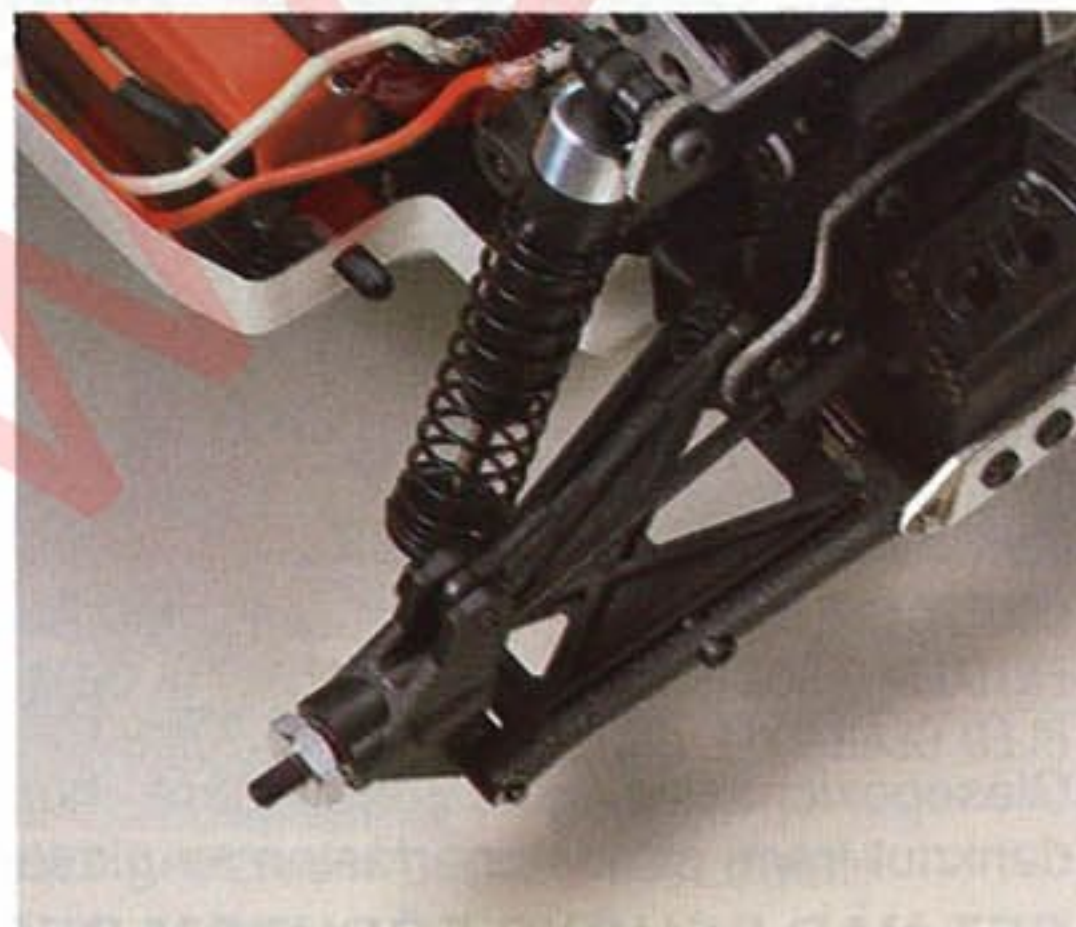

TOOTHED DRIVE BELT. LIGHT, STRONG, RELIABLE. REINFORCED TO PREVENT STRETCHING.

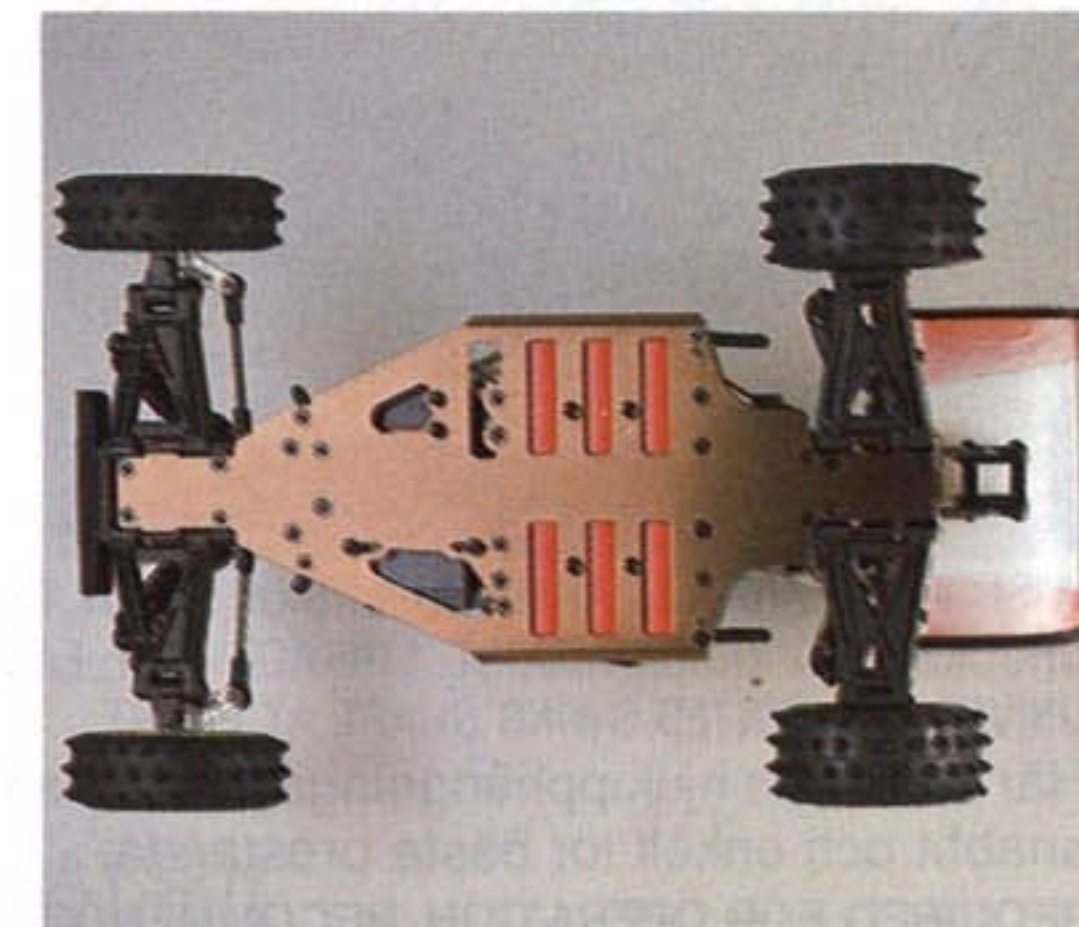

ALLOY ALUMINUM PLATE-TYPE CHASSIS. STRONG. LIGHT.

Kyosho ändrar inte på ett vinnande koncept så delarna i fram & bakvagn känner Du igen från andra MidOptimor. Perfektion som varar!

Kapslad utväxling, nya tryckoljestötdämpare och ett chassie i pläterad flygaluminium som är förberett för de nya "saddle-pack" ack-paketen.

4WD OFF-ROAD RACER OPTIMA MID CUSTOM SPECIAL

ELECTRIC POWERED RACING BUGGY

1:10 SCALE
No. 3140



HAS ALL THE FEATURES OF THE LIMITED-PRODUCTION **TURBO OPTIMA MID SPECIAL** THAT WON THE 1988 EUROPEAN 1/10-SCALE CHAMPIONSHIP. DESIGNED FOR THE SERIOUS COMPETITOR WHO WANTS PREMIUM-QUALITY COMPONENTS AS ORIGINAL EQUIPMENT. KIT INCLUDES **OPTION HOUSE** HIGH-PERFORMANCE METAL-BODY **PRESSURE OIL-FILLED SHOCK ABSORBERS**, UNIVERSAL-JOINTED SWING SHAFTS (FRONT WHEELS), SPECIAL PIN-PATTERN FRONT TIRES AND WHEELS, QUICK-ADJUST LINKAGES FOR EASY CAMBER AND TOE-IN CHANGES, AND A FULL SET OF 16 BALL BEARINGS. ALSO FEATURES A RIGID 17S ALLOY ALUMINUM CHASSIS, GLASS-REINFORCED NYLON SUSPENSION PARTS, GEAR-TYPE DIFFERENTIALS (FACTORY ASSEMBLED), AND FOUR-WHEEL DRIVE VIA A LIGHT, EFFICIENT TOOTHED BELT. KIT DOES NOT INCLUDE MOTOR OR SPEED CONTROLLER BECAUSE EVERY COMPETITOR HAS HIS/HER OWN FAVORITE. ANY ELECTRONIC SPEED CONTROLLER WILL FIT. (KYOSHO **SUPER SPEED 1000** (No. 2593) RECOMMENDED.)

BARA FÖR RACING

En förlängd MidOptima där ingen möda sparats för att göra den till den perfekta racern. Förmodligen marknadens mest "race-färdiga" buggy. Ändå inte på något sätt svår att montera eller att köra. Den levereras utan motor och fartreglage så här väljer Du själv fritt. Får vi föreslå t ex en LeMans Speed 240T? Du kan dessutom välja bland alla olika typer av ack-paket, både standard och "sadle-pack". För Dig som vill ha det absolut bästa för tävlingsbruk rekommenderar vi en OptimaMidCustomSpecial!

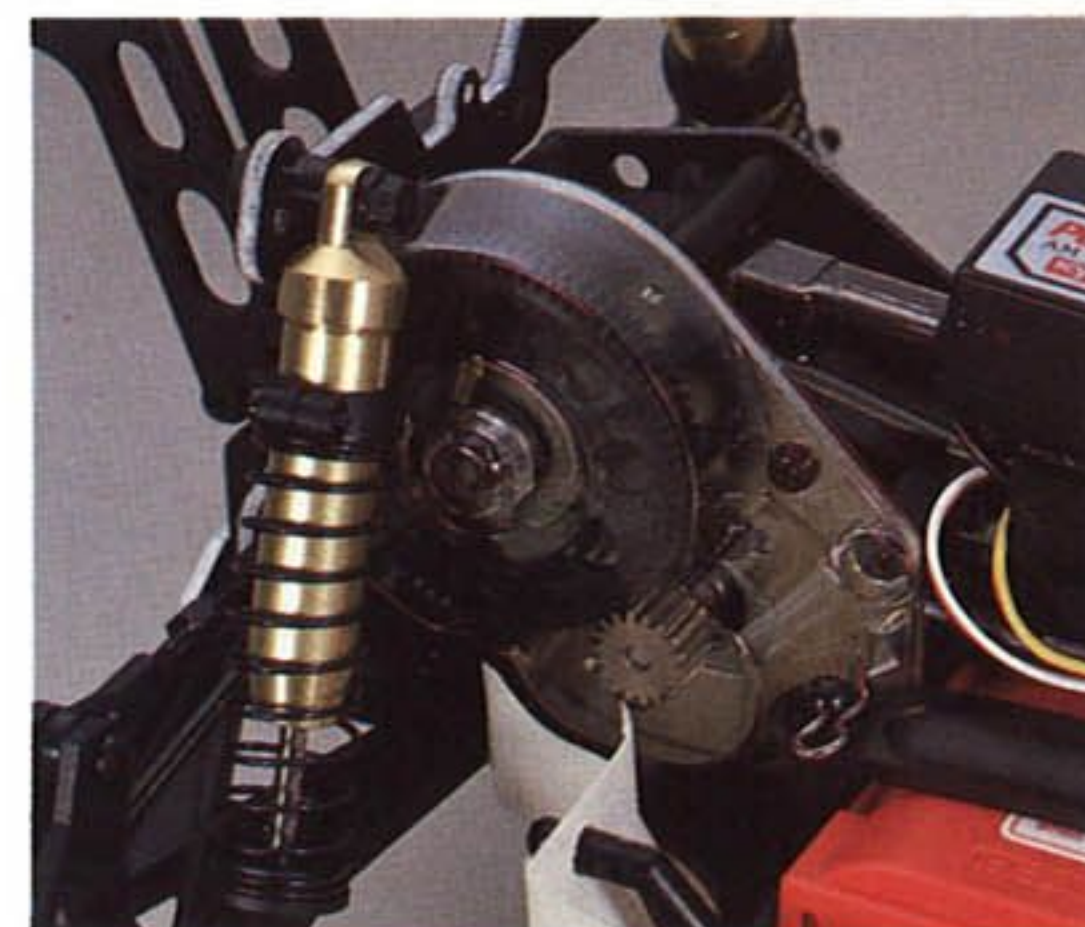

WISHBONE/PARALLEL ARM SUSPENSION FRONT/REAR WITH TOP-QUALITY **OPTION HOUSE** METAL-BODY SHOCKS AND QUICK-ADJUST LINKAGE FOR EASY ADJUSTMENT OF CAMBER AND TOE-IN (FRONT). UNIVERSAL-JOINTED SWING SHAFT AT FRONT.

Här ser Du de hjulupphängningar som skall hjälpa Dig till de stora segrarna. Allt justerbart, snabbt och enkelt för bästa prestanda.

REQUIRED FOR OPERATION/RECOMMENDED FOR BEST APPEARANCE (NOT INCLUDED)

●RADIO CONTROL SET (TWO-CHANNEL WITH STEERING SERVO AND ELECTRIC SPEED CONTROLLER) ●BATTERY (7.2V-1200mAh (STICK TYPE OR SADDLEPACK TYPE) OR 7.2V-1700mAh (STICK TYPE OR SADDLEPACK TYPE) RECHARGEABLE NiCd BATTERY) ●CHARGER FOR NiCd BATTERY ●MOTOR: LeMANS 240/360 TYPE

Technical data ①Length/370mm (14.6") ②Width/240mm (9.4") ③Height/130mm (5.2") ④Wheelbase/273mm (10.7") ⑤Ground clearance/35mm (1.4") ⑥Front track/273mm (8.1") ⑦Rear track/202mm (7.9") ⑧Tires (Front)/ ϕ 85 \times 30mm, (Rear)/ ϕ 85 \times 37mm ⑨Weight (track-ready)/1600g (3 lb 8 oz) ⑩Motor (not included)/LeMans 240 type ⑪Battery (not included)/7.2V-1200/1700mAh NiCd ("stick" type) ⑫Radio control set (not included)/Two-channel

PROTECTIVE COVER OF DRIVE GEARS. DIFFERENTIALS (FRONT/REAR) ARE FACTORY ASSEMBLED GEAR-TYPE UNITS.

Glasepoxichassie, guldstötdämpare, höger/vänster gängade stag, drivaxlar med kardanknut fram, stötdämparfästen av glasepoxi, ny race-buggy kaross med mera.

DET HÄR BEHÖVS FÖRUTOM BYGGSATSEN

En tvåkanals radio, ett elektroniskt fartreglage, en LeMans motor, ett 7.2V/1200mAh ack-paket samt en laddare.

4WD OFF-ROAD RACER *TURBO ROCKY*

ELECTRIC POWERED SPECIAL RACING BUGGY

1:10 SCALE
No. 3103



FOUR-WHEEL DRIVE EXCITEMENT FOR THE EXPERT AND THE NEWCOMER!

- ① NEW LOW-PROFILE BLOCK PATTERN TIRES FOR GOOD TRACTION.
- ② OVERSIZE, ADJUSTABLE, OIL-FILLED SHOCK ABSORBERS.
- ③ GEAR-TYPE DIFFERENTIAL FRONT/REAR.
- ④ FOUR WHEEL DRIVE BY LIGHT, EFFICIENT CHAIN.
- ⑤ 17S RADIO PLATE.
- ⑥ EXTRA-LONG WISHBONE/PARALLEL ARM SUSPENSION FRONT/REAR FOR STABILITY AT SPEED.
- ⑦ BUMPER GUIDES ROCKY OVER MOST OBSTACLES.
- ⑧ ANTI-ROLL BAR FRONT/REAR.
- ⑨ STRONG, LIGHT 17S ALUMINUM ALLOY CHASSIS.
- ⑩ HEAVY-DUTY WIRING FOR 8.4V.
- ⑪ SPEED CONTROLLER: 3 FORWARD, 1 REVERSE.
- ⑫ COMBINED UNIVERSAL JOINT/HALF-SHAFT.

TUFF NYBÖRJAR RACER

TurboRocky är buggyn som kombinerar nybörjarens krav på enkel skötsel med många raciga detaljer och en superhäftig LeMans 240ST motor. Du får en superhäftig racer och maximal körglädje men minimal insats av underhåll. Allt det här är standardutrustning: kedjedrift, differentia-ler, justerbara Platina-oljestötdämpare, fartreglage med silverkontakter, chassie och radioplatå av flygaluminium, hjul/dri-vaxlar med kardankopplingar, krängnings-hämmare och sist men inte minst en super-tuff kaross med inbyggd vinge.

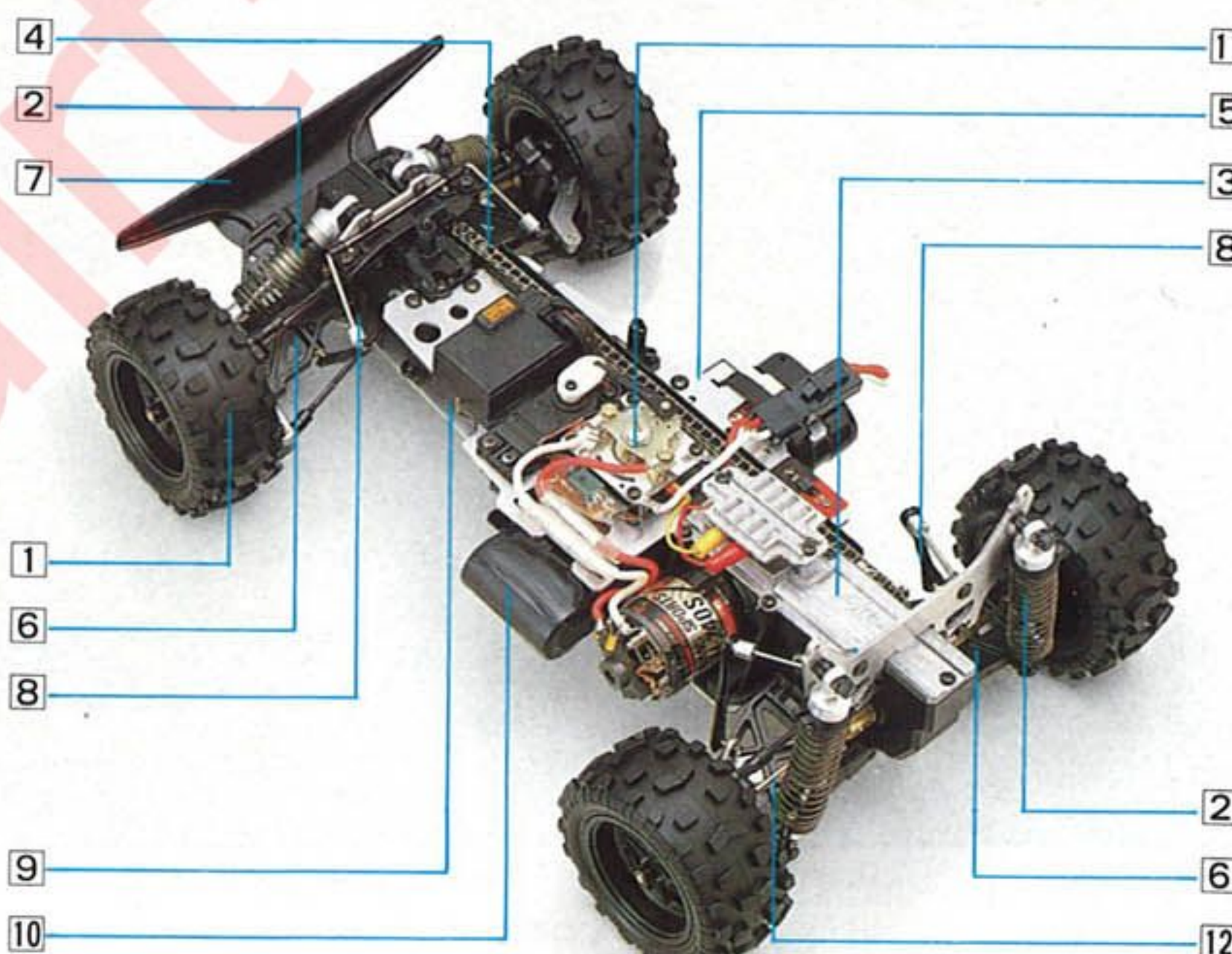

REQUIRED FOR RUNNING / RECOMMENDED FOR BEST APPEARANCE (NOT INCLUDED)

- RADIO CONTROL SET (TWO-CHANNEL) ● MOTOR ● BATTERY (8.4V-1200mAh NiCd)
- BATTERY CHARGER ● POLYCA COLOR PAINT ● MICRON LINE STRIPING TAPE

Technical Data

- ① Length/380mm(14.9in) ② Width/240mm(9.4in) ③ Height/120mm(4.7in) ④ Wheelbase/265mm(10.4in) ⑤ Ground Clearance/30mm(1.2in) ⑥ Front Track/200mm(7.9in) ⑦ Rear Track/190mm(7.5in) ⑧ Tires/(F)85φ×35mm;(R)85φ×35mm
⑨ Total Weight/1600g(3 lb 8 oz) ⑩ Gear Ratio/8.93:1,12.59:1 ⑪ Motor/Le Mans 240/360Type (Not included) ⑫ Battery/8.4V-1200mAh (Not included) ⑬ Radio/2-Channel (Not included)

DET HÄR BEHÖVS FÖRUTOM BYGGSATSEN

En tvåkanals radio, ett 7.2V/1200mAh ack-paket samt en laddare.

SPECIAL RACING CARS

■ HONDA CR-X ■ PEUGEOT 205 ■ PLAZMA MKIII / KS-2
 ■ PLAZMA MKIII / LIMITED ■ AXIS EX

	Name	Length	Height	Weight	Suspension	Shock Absorbers	Ball Bearings	Motor	Battery	Potential For Hop-up*
2	HONDA CR-X	315mm	110mm	1100g	(F) WS; (R) WS	4 Oil-filled	(Not included)	LeMans Stock 05	7.2V-1200mAh	△
	PEUGEOT 205	320mm	110mm	1100g	(F) WS; (R) WS	4 Oil-filled	(Not included)	LeMans Stock 05	7.2V-1200mAh	△
W	PLAZMA MKIII KS-2	350mm	80mm	880g	(F) SS; (R) TS	Oil-filled	2 pcs.	LeMans 600E	7.2V-1200mAh	◎
D	PLAZMA MKIII LIMITED	350mm	80mm	880g	(F) SS; (R) TS	Oil-filled	8 pcs.	LeMans 480 Type (not included)	7.2V-1200mAh	◎
	AXIS EX	350mm	80mm	900g	(F) KT; (R) TS	Oil-filled, 2 friction	9 pcs.	LeMans 480 Type (not included)	7.2V-1700mAh	△

(F)=FRONT, (R)=REAR, WS=DOUBLE WISHBONE or WISHBONE/PARALLEL ARM, TS=TRAILING ARM, SS=SLIDING PILLAR *◎High, ○Moderate, △Low

ELECTRIC POWERED SPECIAL RACING CARS

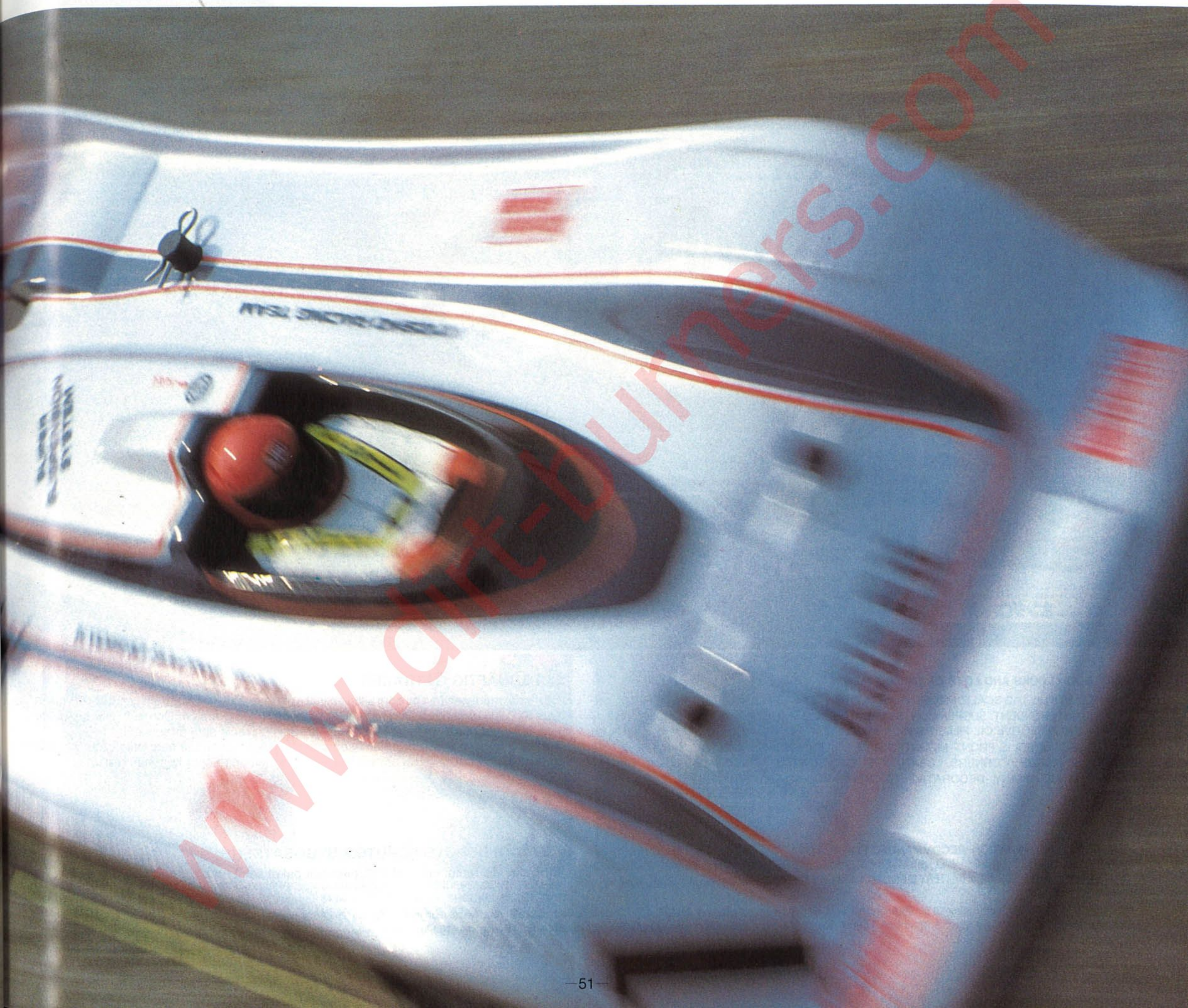



RACY GOOD LOOKS AND LOTS OF DRIVING FUN!

THIS BEAUTIFUL 1/12-SCALE MODEL RUNS AT REALISTIC SPEED AND HAS A FULLY FUNCTIONING INDEPENDENT SUSPENSION SYSTEM FRONT AND REAR, WITH DOUBLE WISH-BONES AND EFFECTIVE OIL-FILLED SHOCK ABSORBERS. THE POWERFUL *Le MANS STOCK 05* MOTOR (INCLUDED) IS FRONT MOUNTED AND DRIVES THE FRONT WHEELS TO PULL THE MODEL THROUGH CORNERS. GEAR-TYPE DIFFERENTIAL. EASY ASSEMBLY. SIMPLE MAINTENANCE. MANY DECORATIVE STICKERS. TREAD-PATTERN TIRES. IDEAL FIRST CAR.

REQUIRED FOR OPERATION/RECOMMENDED FOR BEST APPEARANCE (NOT INCLUDED)

●RADIO CONTROL SET (TWO-CHANNEL) ●BATTERY (7.2V-1200mAh OR 7.2V-1700mAh RECHARGEABLE NiCd BATTERY) ●CHARGER FOR NiCd BATTERY ●POL YCA COLOR PAINT ●MICRON LINE STRIPING TAPE

Technical Data

①Length/315mm(12.4in) ②Width/165mm(6.5in) ③Height/110mm(4.4in) ④Wheelbase/190mm(7.5in) ⑤Ground Clearance/5mm(0.2in) ⑥Front Track/136mm(5.3in) ⑦Rear Track/136mm(5.3in) ⑧Tires/(F/R)φ58×27mm
⑨ Weight/1100g(38.7oz) ⑩Gear Ratio/3.8:1 ⑪Motor/Le Mans stock 05(Included) ⑫Battery/7.2V-1200mAh(Not included) ⑬Radio/Two-channel(Not Included)

SUPERHÄFTIG GATRACER

Det här är modellen för Dig som alltid önskat en supervass gatracer men tyckt att 100-tusen varit för mycket pengar. Den här kostar bara drygt hundradelen! Och den axar snabbare upp till sin toppfart - utan tvekan. Framhjuldriven precis som förebilden. Tuff som få med den breda karossen och de riktigt mönstrade lågprofildäcken på tuffa turbinfälgar. En racer som gör sig lika bra på asfaltbanan som hemma i hyllan!

DET HÄR BEHÖVS FÖRUTOM BYGGSATSEN

En tvåkanals radio, ett 7.2V/1200mAh ack-paket samt en laddare.

FF RACER HONDA CR-X
ELECTRIC POWERED FF RACING CAR
No. 3171

FF RACER PEUGEOT 205
ELECTRIC POWERED FF RACING CAR
No. 3172

1:12 SCALE



- 1 STRONG NYLON BUMPER FOR CRASH PROTECTION.
- 2 DOUBLE-WISHBONE INDEPENDENT SUSPENSION FRONT REAR WITH OIL-FILLED SHOCK ABSORBERS.
- 3 ALUMINUM SAFETY CAGE AROUND RESISTORS.
- 4 STRONG, LIGHT 17S ALUMINUM CHASSIS.
- 5 ABS RADIO PLATE.
- 6 SEMI-PNEUMATIC TIRES WITH ROAD TREAD PATTERN.
- 7 STYLISH, STRONG, LIGHT ONE PIECE NYLON WHEELS.
- 8 POWERFULL *LeMANS STOCK 05* MOTOR (INCLUDED).
- 9 DIRECT-MOUNTED SERVO SAVER FOR STEERING SERVO.
- 10 SPEED CONTROLLER. (3 FORWARD, 2 REVERSE)
- 11 SPEED CONTROLLER. SERVO. (NOT INCLUDED)

- 1 Kraftig stötfångare av nylon.
- 2 Individuell hjulupphängning och fungerande oljestötdämpare runt om.
- 3 Resistor med kylplåt.
- 4 Chassie av aluminium i 17S legering.
- 5 Radioplatå av seg tålig ABS plast.
- 6 Lågprofilsdäck med riktigt mönster.
- 7 Fälgar av turbintyp av stark nylon.
- 8 Stark LeMans Stock05 motor.
- 9 Servoräddare direkt på styrservot.
- 10 Fartreglage med silverkontakter.

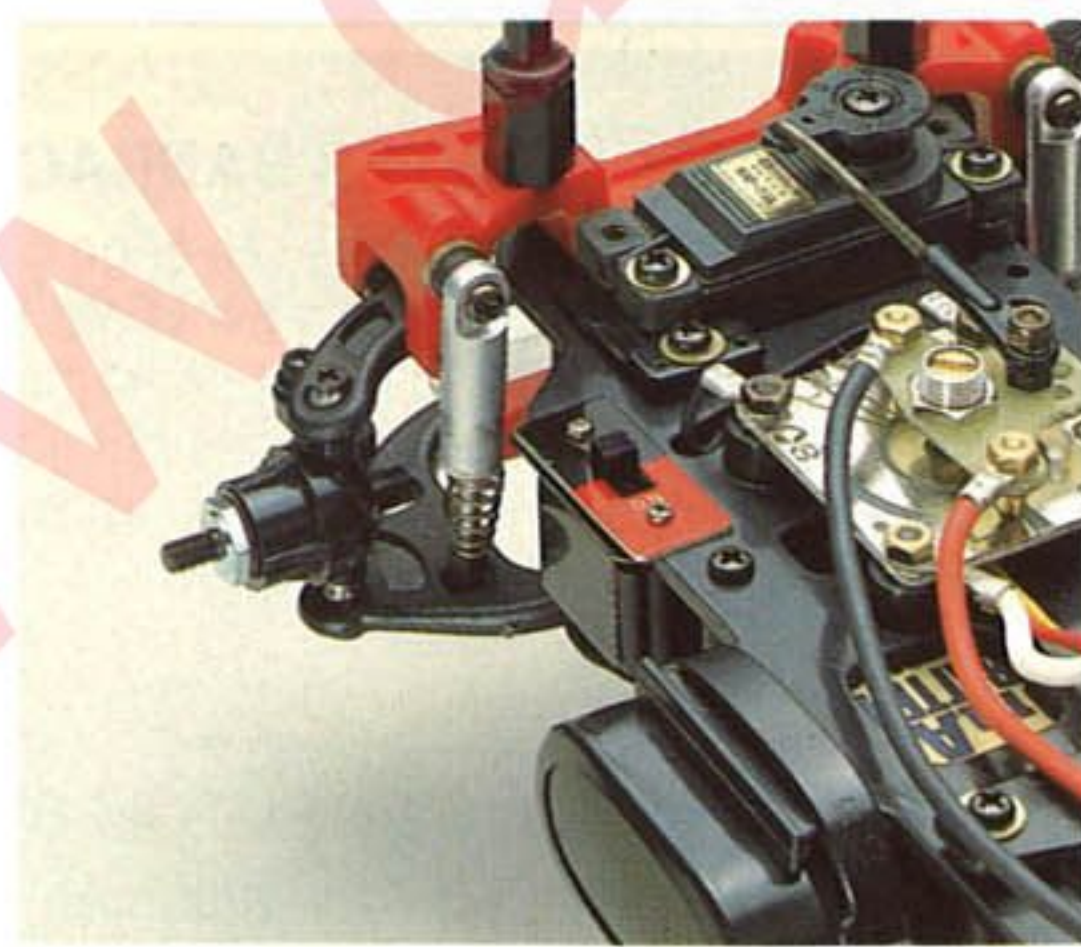
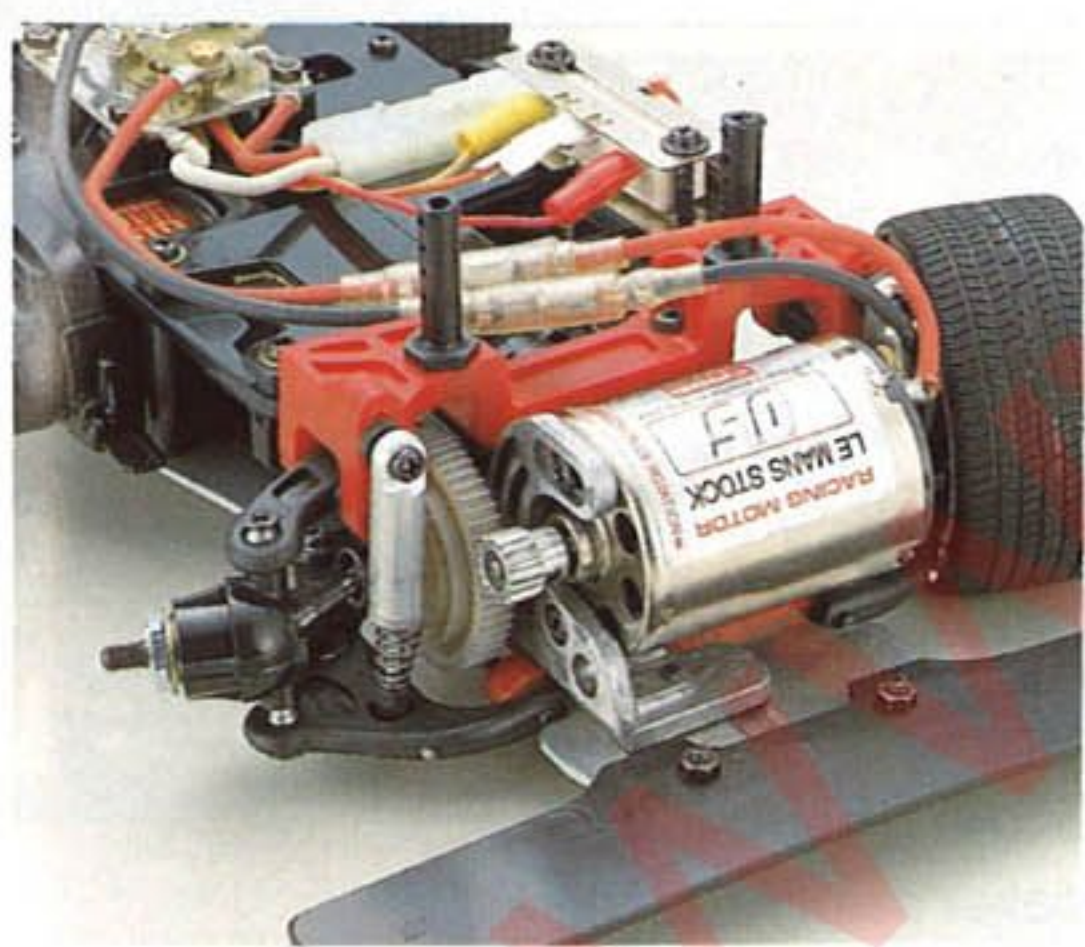

■ FF RACER "PEUGEOT 205,,



FRONT-WHEEL DRIVE FOR REALISTIC DRIVING PERFORMANCE. POWERFUL *LeMANS STOCK 05* MOTOR.

DOUBLE-WISHBONE INDEPENDENT SUSPENSION WITH FRICTION SHOCKS FRONT AND REAR. GOOD ROADHOLDING.

OPERATING HEADLIGHTS.

Avancerad chassiekonstruktion med oljestötdämpare runt om. Framhjulsdrift med frontmonterad motor.

Fungerande huvudstrålkastare.



THE GREAT LITTLE PLAZMA CONTINUES, EVEN BETTER THAN EVER!

A GOOD COMPETITOR AGAINST CARS COSTING SIX TIMES AS MUCH, PLAZMA OFFERS "GO" WITH A CAPITAL "G"! SLIDING PILLAR FRONT SUSPENSION ALLOWS INDEPENDENT WHEEL MOVEMENT WHILE KEEPING THE WHEELS PERPENDICULAR TO THE TRACK. LIVE REAR AXLE IS LOCATED AND SPRUNG BY THE FRP CHASSIS PLATE AND A FRICTION MONO-SHOCK. TWIN BALL BEARINGS ON REAR AXLE. OPTIONAL 4WD. QUALITY ALUMINUM PARTS.

REQUIRED FOR OPERATION / RECOMMENDED FOR BEST APPEARANCE (NOT INCLUDED)

●RADIO CONTROL SET (TWO-CHANNEL) ●MOTOR ●BATTERY (7.2V-1200mAh OR 7.2V-1700mAh RECHARGEABLE NiCd BATTERY) ●CHARGER FOR NiCd BATTERY ●POLYCA COLOR PAINT ●MICRON LINE STRIPING TAPE

Technical Data/ < >: PLAZMA MKIII LIMITED

①Length/350mm(13.8in) ②Width/170mm(6.7in) ③Height/80mm(3.1in) ④Wheelbase/200mm(7.9in) ⑤Ground Clearance/5mm(0.2in) ⑥Front Track/137mm(5.4in) ⑦Rear Track/133mm(5.2in) ⑧Tires (F)φ47×23mm;(R)φ52×35mm ⑨Total Weight/870g(31oz) ⑩Gear Ratio/3.7:1 ⑪Motor/Le Mans 600E(Included) Le Mans 240/480type;Not included ⑫Battery/7.2V-1200mAh(Not included) ⑬Radio/Two-channel(Not included)

PLAZMA MK III HETER BANRACERN

Tävlingar med banbilar körs i Sverige oftast inomhus på heltäckningsmatta av nålfiltstyp. Där passar Plazma med sin minimala frigång perfekt. Chassiekonstruktionen bygger på en minimal fjädringsväg direkt på främre styrspindlarna och en mjukt upphängd bakvagn stöttad av en högt placerad oljestötdämpare. Materialet i de olika delarna är högklassiga typer av nylon, aluminium och glasepxi. Bakaxeln är kullagrad och den levereras med en LeMans 600E bantävlingsmotor.

DET HÄR BEHÖVS FÖRUTOM BYGGSETSEN

En tvåkanals radio, ett 7.2V/1200mAh ack-paket samt en laddare.

PLAZMA MK III KS-2

ELECTRIC POWERED SUPER-LIGHT RACING CAR

No. 3151

PLAZMA MK III LIMITED α -II

ELECTRIC POWERED SUPER-LIGHT RACING CAR

No. 3152

1:12 SCALE



1 PILLAR-TYPE INDEPENDENT FRONT SUSPENSION.

2 DIRECT-MOUNTED SERVO SAVER.

3 MOLDED SPONGE HIGH-GRIP TIRES.

4 STIFF, LIGHT, FRP PLATE CHASSIS.

5 OIL-FILLED SHOCK ABSORBER.

6 POWERFUL LeMANS 600E MOTOR (INCLUDED).

7 ALUMINUM REAR AXLE CARRIER.

8 REAR AXLE BALL BEARING (X2)

1 Hjulupphängning med avfjädrade styrspindlar.

2 Servoräddare monterad direkt på servot.

3 Fartreglage med lättviktresistor.

4 Chassie av styv glasepxi.

5 Oljestötdämpare för rätt dämpning av bakvagnen.

6 LeMans 600E motor med ställbar tändning.

7 Bakaxelbox av aluminium ger vridstyvhet.

8 Bakaxel av flygaluminium lagrad i kullager.

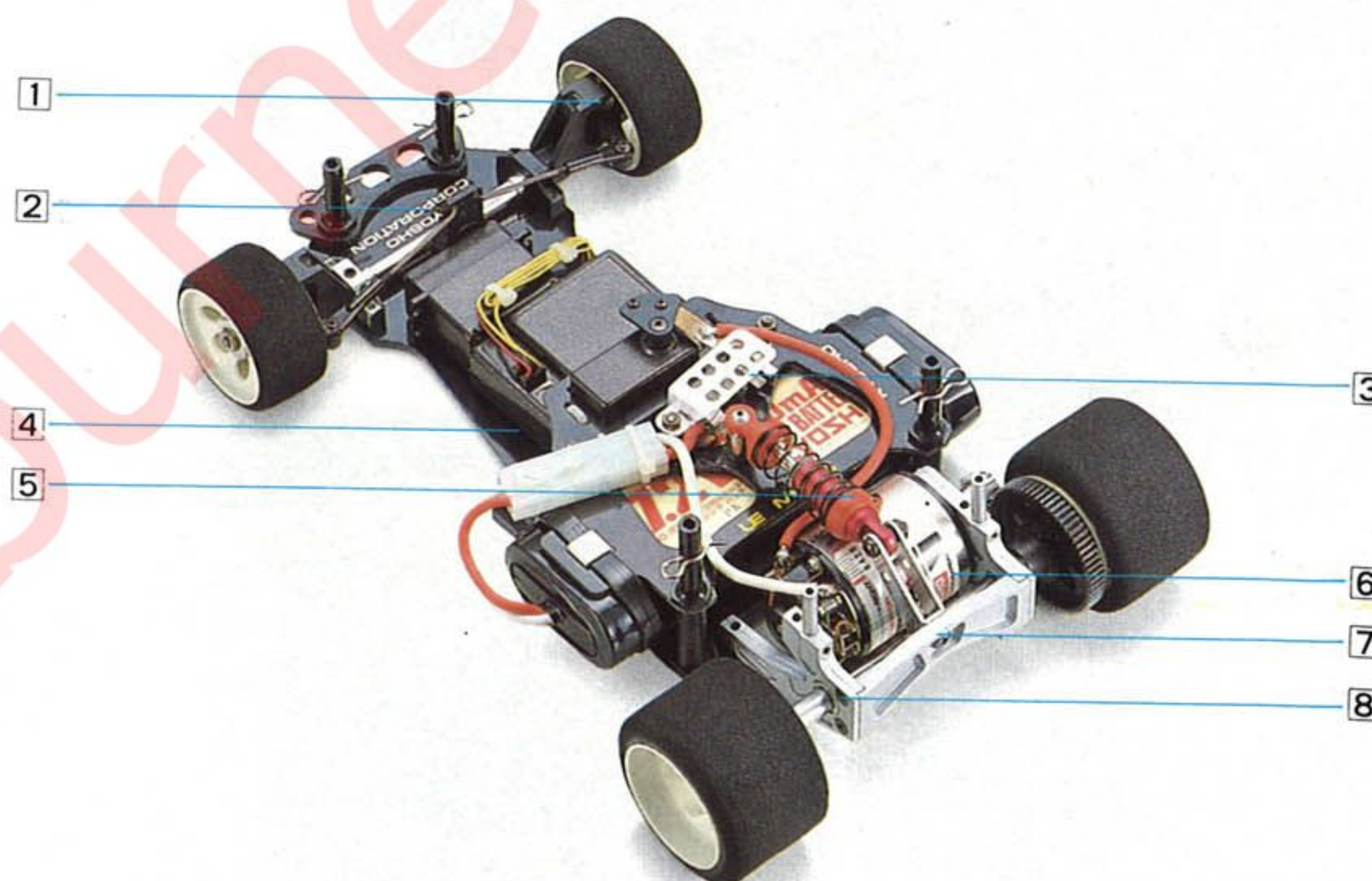

PLAZMA MK III LIMITED α -II

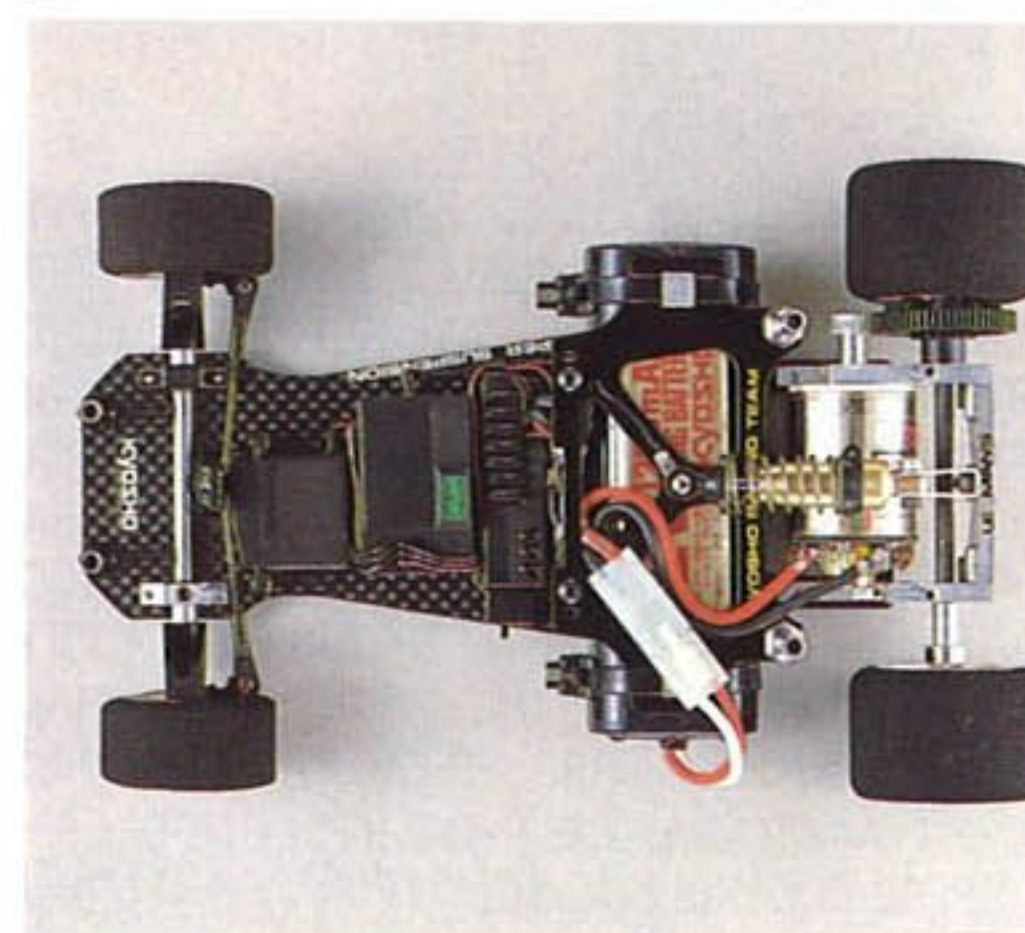

● SUPER-STRONG CARBON-FIBER/EPOXY CHASSIS PLATE.

● HIGH-STRENGTH 17S ALLOY REAR AXLE CARRIERS.

● HIGH-PERFORMANCE PRESSURE-TYPE REAR SHOCK ABSORBER.

● EIGHT BALL BEARINGS FOR MINIMUM FRICTION.

PLAZMA MK III LIMITED är en racingvariant som levereras fullt kullagrad men utan motor och fartreglage (avsedd för elektroniskt fartreglage). Chassie och bakaxel tillverkade av "rymdmaterialet" kolfiber. Bakvagnsbox i precisionsfräst superaluminium 17S.

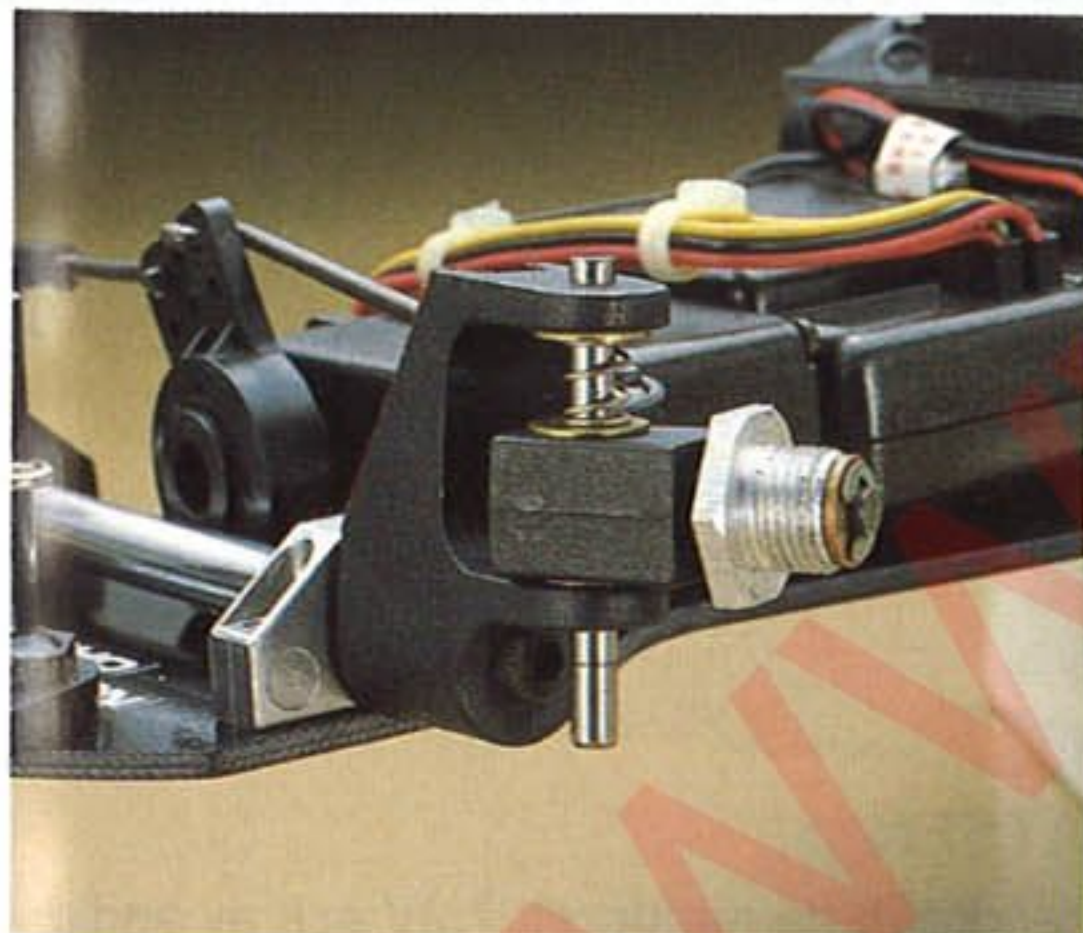

PILLAR-TYPE INDEPENDENT FRONT SUSPENSION.

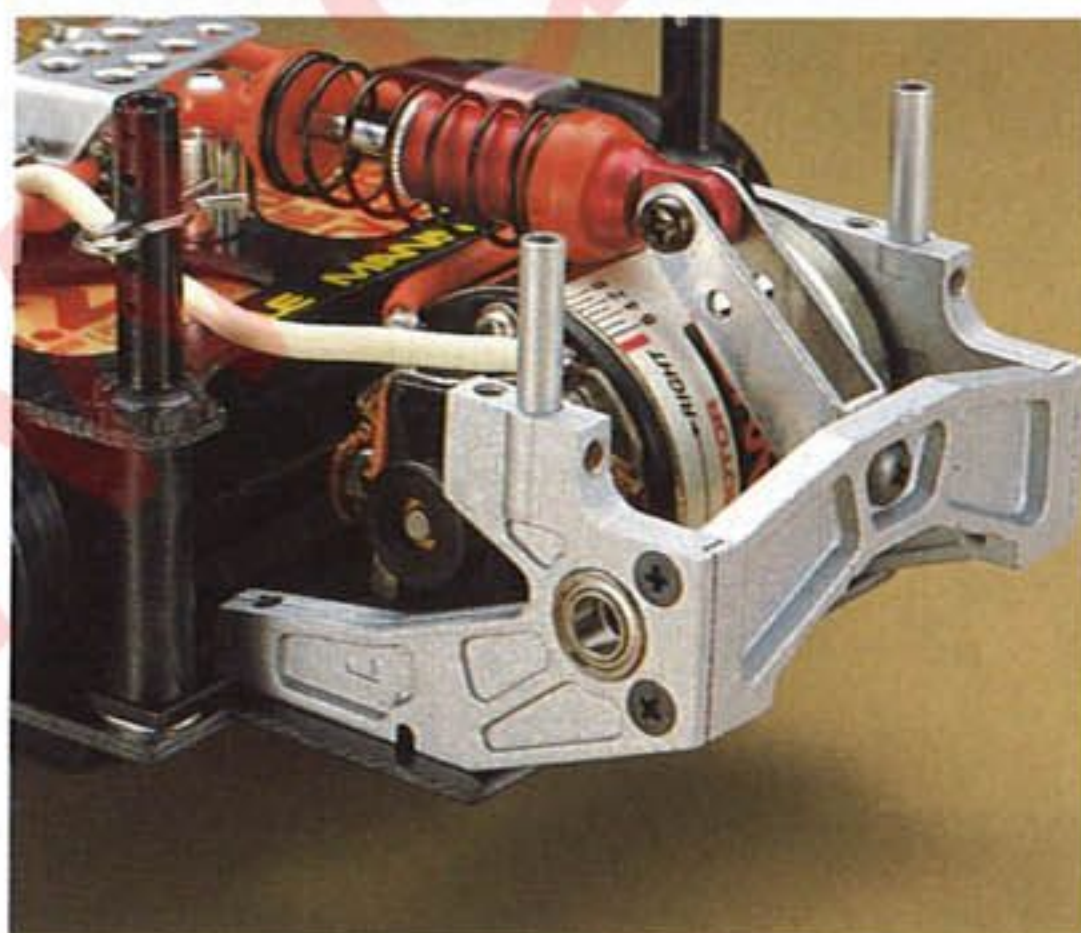

REAR AXLE BALL BEARINGS (2) FOR MINIMUM FRICTION, HIGHEST SPEED.

Detaljprecision i fram och bakvagn ger utslag på tävlingsbanan. Plazma MK III är den rätta banracern att börja karriären med.

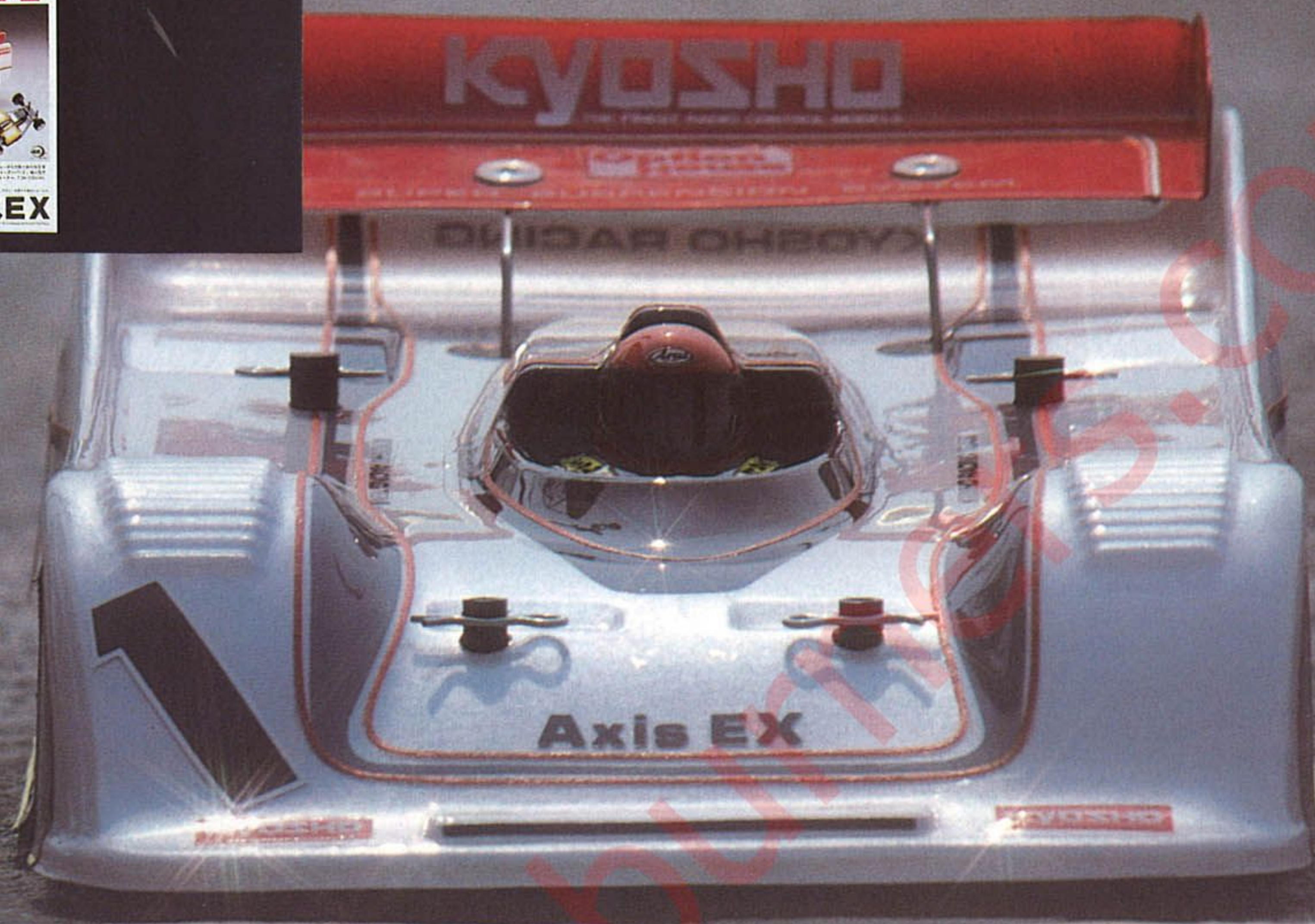

FOR SUPER-FAST ON-ROAD RACING!

COMPETITION-READY RIGHT OUT OF THE BOX! ALL PERFORMANCE PARTS INCLUDED. SUPER-LIGHT, SUPER-STRONG 1.9mm CARBON-EPOXY CHASSIS PLATE. SUSPENSION PARTS INDIVIDUALLY MACHINED FROM ALLOY ALUMINUM. EFFICIENT AND LIGHT BALL-TYPE DIFFERENTIAL WITH FINE CERAMIC DISCS (A WORLD FIRST). FINE-PITCH GEARS FOR SMOOTHEST POWER DELIVERY. WEAR-RESISTANT STAINLESS STEEL PINION. CARBON-EPOXY REAR AXLE FOR MAXIMUM STIFFNESS WITH MINIMUM WEIGHT. PROVEN SLIDING-PILLAR FRONT SUSPENSION THAT KEEPS WHEELS PERPENDICULAR TO TRACK FOR MAXIMUM TRACTION. REAR SUSPENSION OPTIMIZED FOR SINGLE/DOUBLE WHEEL BOUNCE WITH ONE OIL-FILLED PRESSURE SHOCK ABSORBER AND TWO FRICTION TYPE SHOCKS. CHASSIS PLATE CUTOUTS FOR LOWEST POSSIBLE SADDLE-PACK BATTERY POSITION: LOWEST CG AND FASTEST SPEED THROUGH CORNERS. HIGH-GRIP SPONGE TIRES AND LIGHTWEIGHT WHEELS STANDARD. EXCELLENT ON CARPET OR ASPHALT. FULL SET OF BALL BEARINGS.

REQUIRED FOR OPERATION / RECOMMENDED FOR BEST APPEARANCE (NOT INCLUDED)

●RADIO CONTROL SET (TWO-CHANNEL WITH ELECTRONIC SPEED CONTROLLER) ●BATTERY (7.2V-1700mAh SCE NiCd SADDLE-PACK TYPE) ●CHARGER FOR NiCd BATTERY ●POLYCA COLOR PAINT ●MICRON LINE STRIPING TAPE

Technical Data

①Length/350mm (13.8") ②Width 170mm (6.7") ③Height/80mm (3.1") ④Wheelbase/202mm (8.0") ⑤Ground clearance 5mm (0.2") ⑥Front track/143mm (5.6") ⑦Rear track/135mm (5.3") ⑧Tires (F)φ48×23mm; (R)φ53×35mm ⑨Weight 900g (32oz) ⑩Gear ratio/4.41:1 or 4.32:1 ⑪Motor (not included) LeMans 240 or 480 type; SPA 240 or 480 type ⑫Battery (not included) 7.2V-1700mAh "saddle pack" type ⑬Radio control set (not included) two-channel with electronic speed controller

AXIS - DEN FULLÄNDADE BANRACERN

Det här är den bil den regerande mästaren i 1/8 banbil, Anders Ljungqvist, valde att köra säsongen 88-89 i elbilsklassen. Redan detta säger en hel del om den nya Axis. Banelbil i skala 1:12 är förmodligen den tuffaste och mest "täta" tävlingsklassen för radiostyrda modeller. Den klass som kräver mest av både förare och bil. Det är därför här mer än i någon annan klass viktigt att välja rätt. Välj AXIS EX! Och sikta på seger!

DET HÄR BEHÖVS FÖRUTOM BYGGSATSEN

En tvåkanals radio, ett elektroniskt fartreglage, en LeMans motor, ett 7.2V ack av sadlepack-typ samt en laddare.

AXIS EX

ELECTRIC POWERED SPECIAL RACING CAR

1:12 SCALE

No. 3153



- 1 SLIDING-PILLAR SUSPENSION. FLAT CORNERING AND GOOD STEERING RESPONSE.
- 2 DIRECT-ACTION SERVO SAVER FOR PRECISE CONTROL WITH SERVO PROTECTION.
- 3 CARBON-FIBER REINFORCED MAIN CHASSIS (1.9MM) AND SUB-CHASSIS (1.6MM).
- 4 HIGH-CAPACITY PRESSURE SHOCK ABSORBER FOR GOOD REAR-WHEEL BOUNCE CONTROL.
- 5 TWO FRICTION-TYPE SHOCK ABSORBERS FOR CONTROL OF SINGLE-WHEEL BOUNCE.
- 6 MOTOR (NOT INCLUDED).
- 7 STRONG, DURABLE 17S ALLOY ALUMINUM MOTOR MOUNT.
- 8 BALL-TYPE DIFFERENTIAL WITH CERAMIC PRESSURE PLATE.

- 1 Avfjädrade främre styrspindlar för kvick respons.
- 2 Servoräddare med minimalt glapp monterad direkt på servot.
- 3 Kolfiberförstärkta chassieplattor för rätt styvhet.
- 4 Kraftig bakvagnsdämpare av guld-typ.
- 5 Friktionsdämpare på varje sida för total bakvagnskontroll.
- 6 Bakaxel av kolfiber för rätt styrka.
- 7 Motorfäste/bakvagn av superaluminium (17S).
- 8 Differential av kultyp med keramiska (!) tryckplattor.

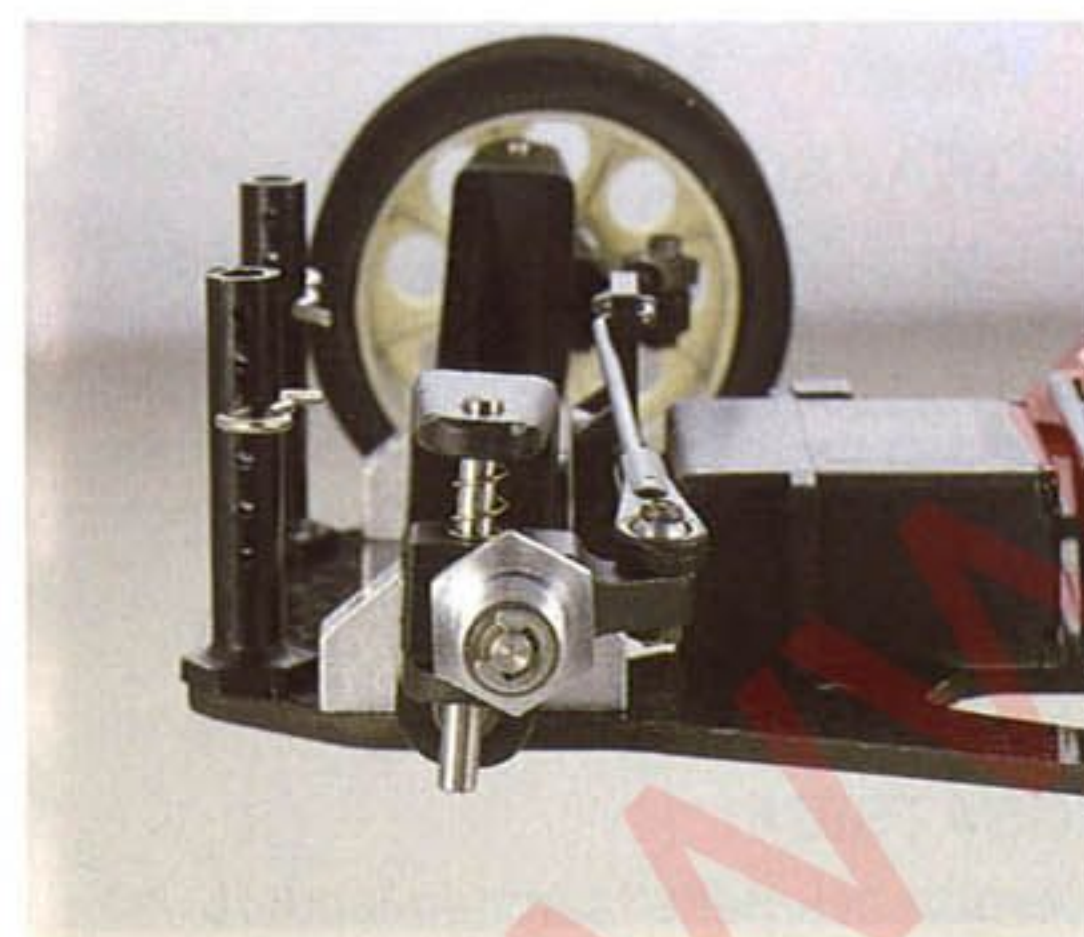
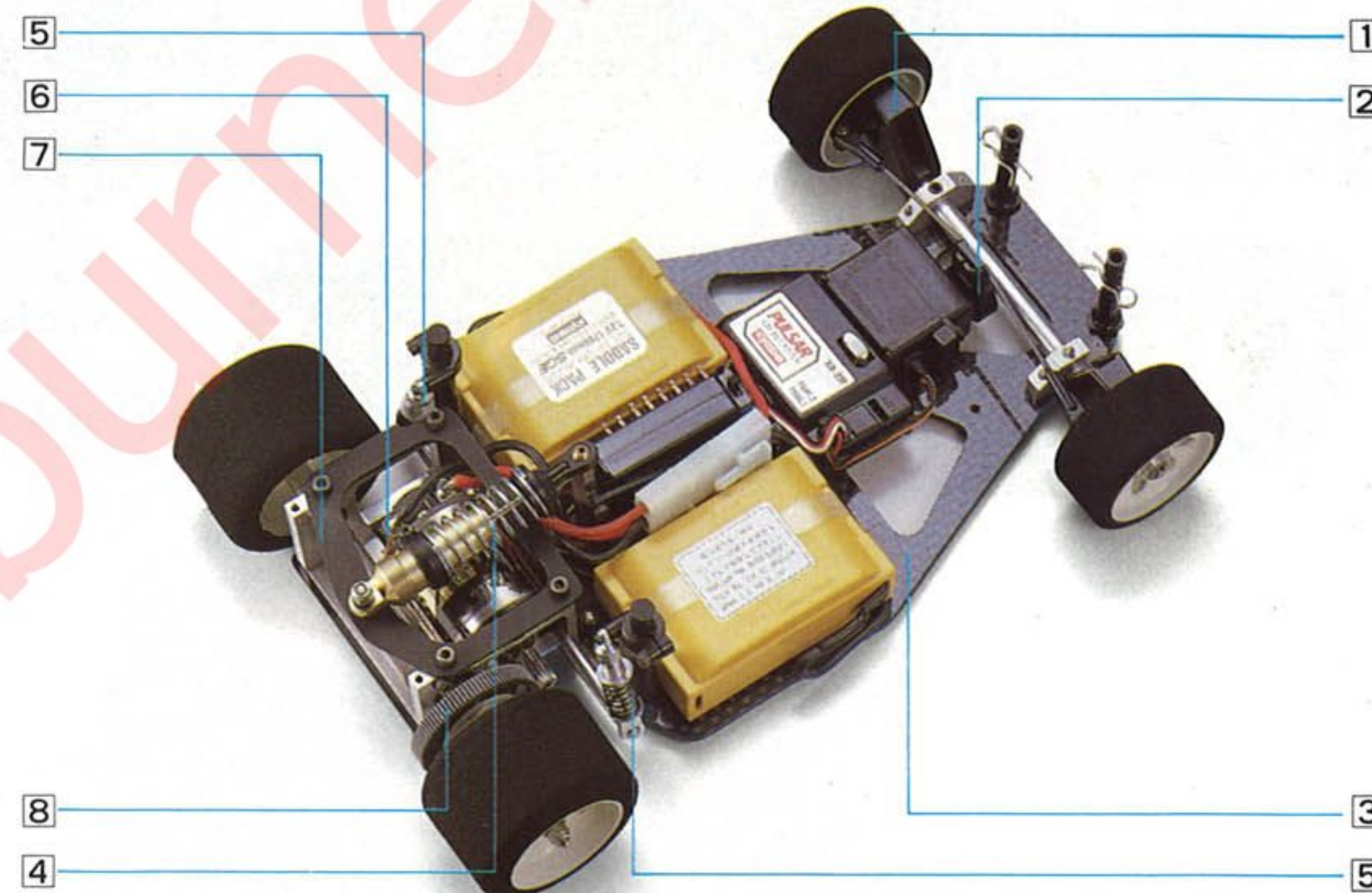

SLIDING PILLAR AND COIL SPRING FRONT SUSPENSION. ADEQUATE TRAVEL WITH PARALLEL WHEEL TRAVEL.

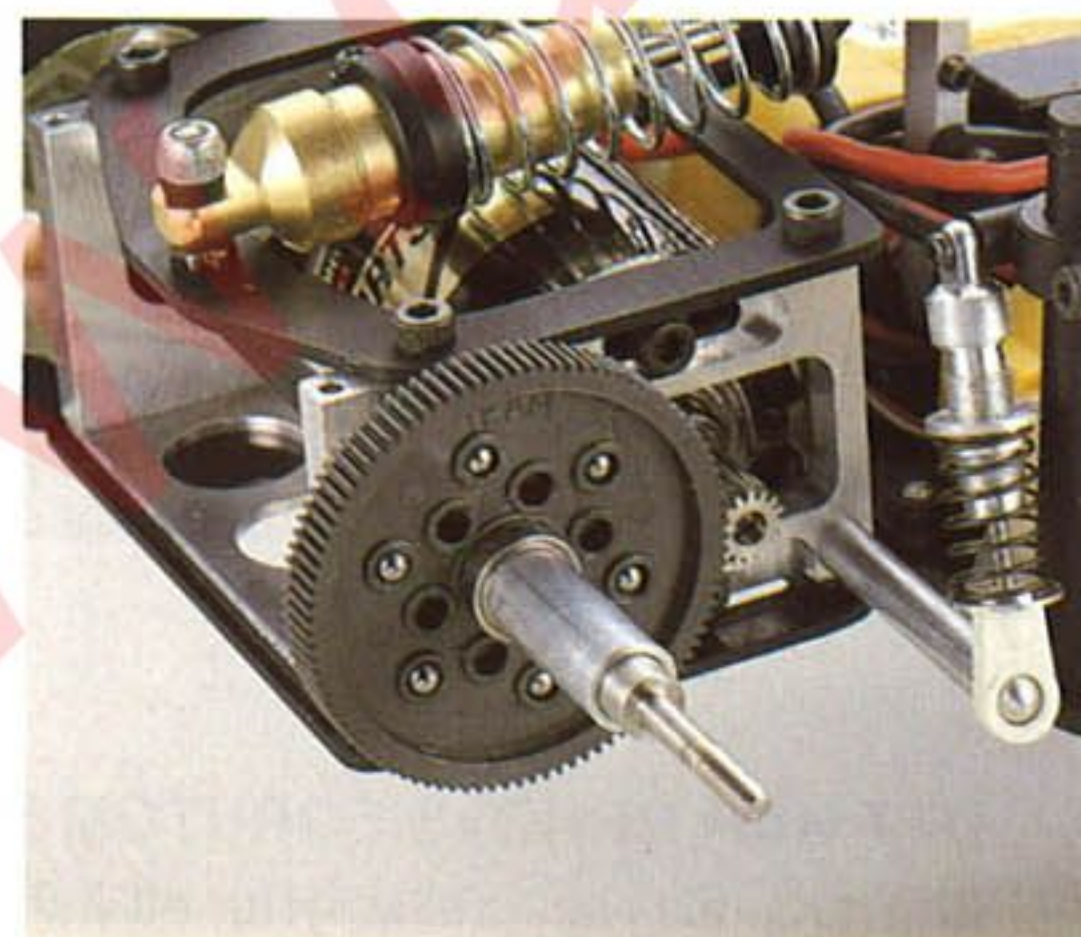

ANTI-ROLL MICRO FRICTION-TYPE SHOCKS AND LARGE OIL-FILLED REAR SHOCK.

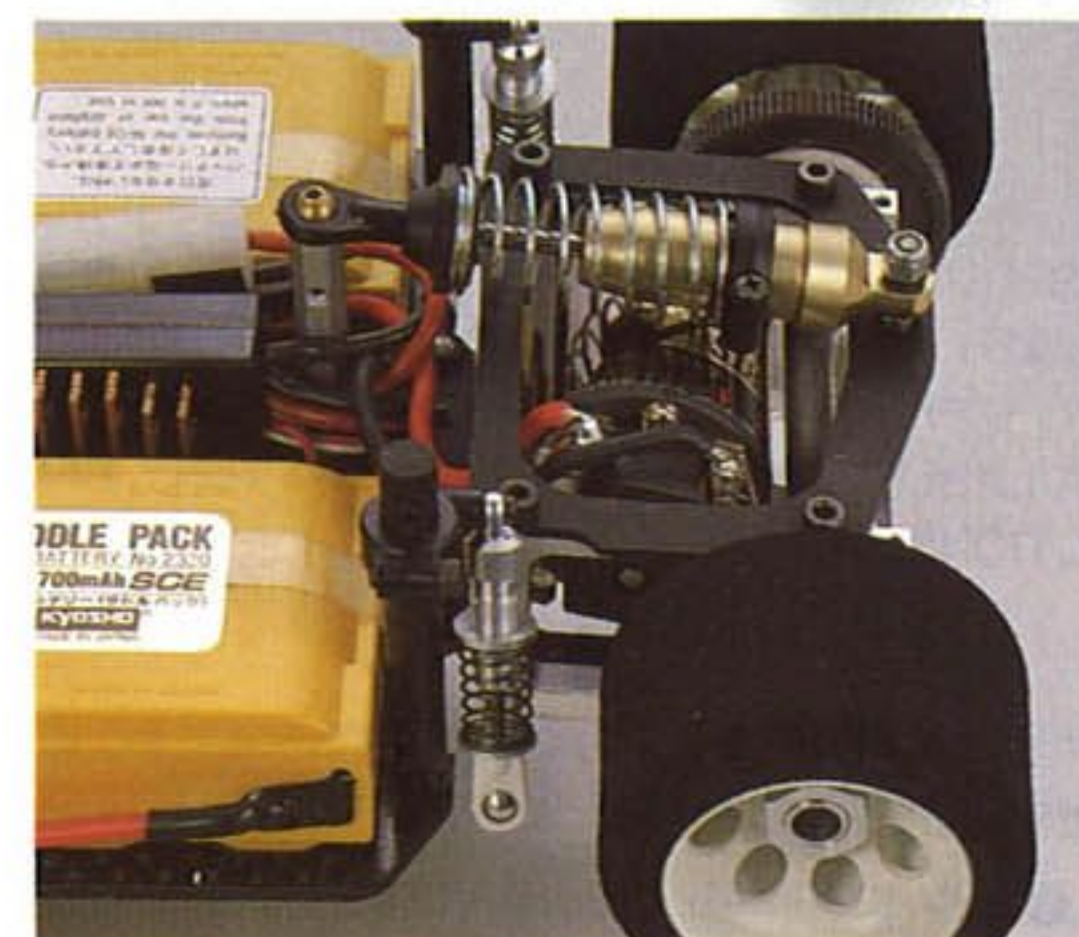

STRONG, LIGHT 17S MOTOR MOUNT.

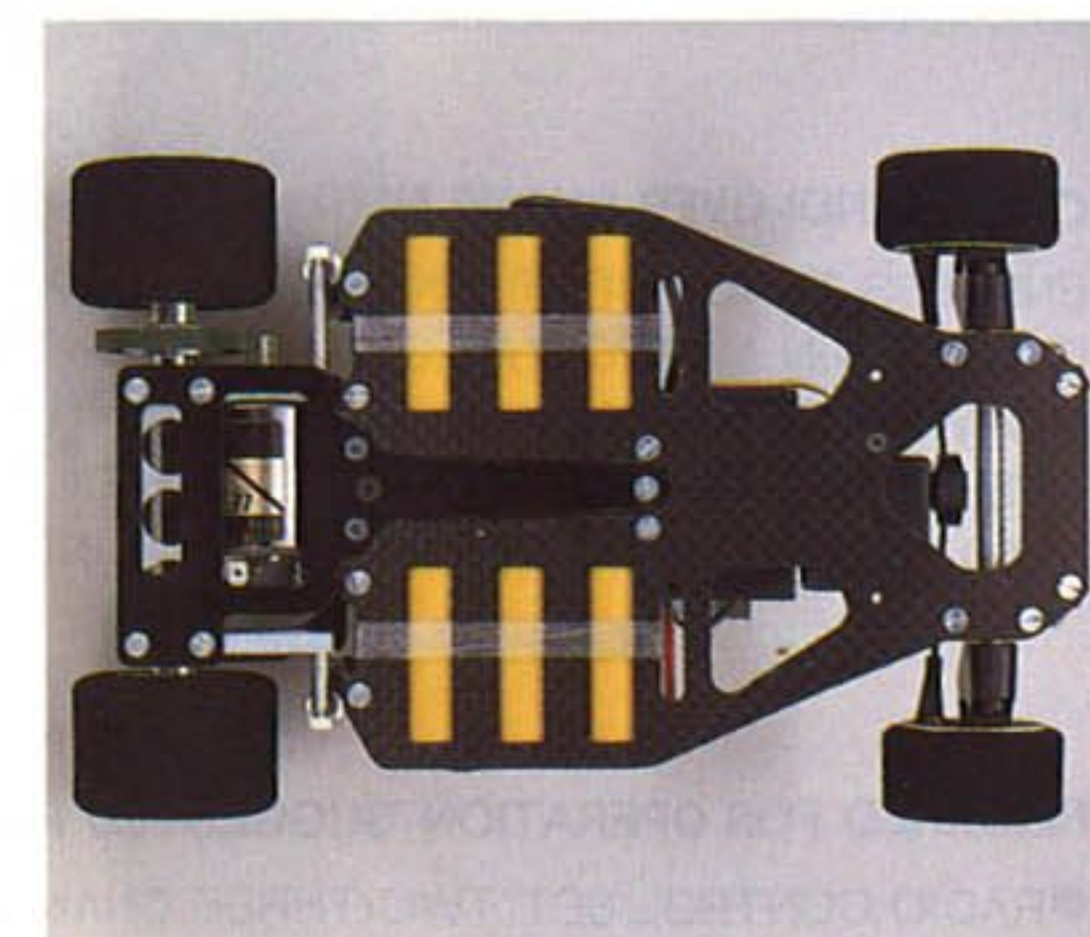

CARBON-FIBER REINFORCED CHASSIS WITH INTEGRAL REAR SPRINGING.

Precision i minsta detalj är viktig. Helt vertikal fjädringsväg fram. Bakvagnen dämpad av tre stötdämpare med fjädrar.

Ren chassiekonstruktion underlättar underhållet. Avsedd för sk sadle-pack ack. Lätta men starka fälgar av nylon.



OVER SAND! OVER SNOW! NOTHING STOPS THE BLIZZARD ALL-TERRAIN VEHICLE!

ENDLESS-TRACK DRIVE AND INDEPENDENTLY SPRUNG BOGEYS TO SNAKE OVER OBSTACLES. TWIN MABUCHI RS-380 DRIVE MOTORS WITH TWIN STEPLESS SPEED CONTROLLERS (FORWARD AND REVERSE) FOR SHARP-TURNING DIFFERENTIAL-TRACK STEERING. SERVO OPERATED PLOW (OPTION). USES READILY AVAILABLE 7.2V-1200mAh NiCd BATTERY PACK. CLEAR, EASY-TO-FOLLOW ASSEMBLY INSTRUCTIONS.

REQUIRED FOR OPERATION / SUGGESTED FOR BEST APPEARANCE

- RADIO CONTROL SET TWO/THREE CHANNEL ● 7.2V-1200mAh NiCd BATTERY PACK (ONE OR TWO) ● CHARGER
- POLYCA COLOR PAINT

Technical Data

① Length/360mm(14.2in) ② Width/304mm(12.0in) ③ Height/225mm(8.9in) ④ Wheelbase/300mm(11.8in) ⑤ Tracks (circumference) /90×750mm(3.5×29.5in) ⑥ Total Weight /2400g(5.3lb) ⑦ Gear Ratios 12:1 32:1 ⑧ Motor RS-380S×2 (Included) ⑨ Battery/7.2V-1200mAh(Not included) ⑩ Radio/ Two-channel (Not included)

PISTMASKIN MED EXTREM TERRÄNGKAPACITET

Den som sett en pistmaskin klättra vet att den tar sig fram nästan var som helst. Det här är en mycket trogen modell där även drivningen och styrningen liknar den verkliga. Den körs normalt med en vanlig tvåkanals radio men en fyrkanals radio har Du möjlighet att även sköta plogen från radiosändaren. Du kör den där det är roligast och styr den enkelt och snabbt genom att reglera hastigheten på de två banden. Dubbla motorer och dubbla fartregalge gör detta möjligt.

DET HÄR BEHÖVS FÖRUTOM BYGGSATSEN

En tvåkanals radio (eller fyra), ett 7.2V/1200mAh ack-paket samt en laddare.

THE BLIZZARD

ELECTRIC POWERED R/C ALL-TERRAIN VEHICLE

1:12 SCALE

No. 2435



- 1 FLASHING ROOF LIGHT (OPTIONAL).
- 2 STRONG POLYCARBONATE BODY. DECORATE TO YOUR OWN TASTE.
- 3 ADDED REALISM WITH FORDING MUFFLER (OPTIONAL).
- 4 STEERING CONTROLLER.
- 5 PROTECTIVE "TUB" TYPE CHASSIS.
- 6 FACTORY-ASSEMBLED GEARBOX. GEAR RATIO EASILY CHANGED. (TWO RATIOS AVAILABLE.)
- 7 BATTERY (NOT INCLUDED). ONE OR TWO CAN BE USED.
- 8 SPEED CONTROLLER (FORWARD/REVERSE).
- 9 TRAILING-LINK INDEPENDENT SUSPENSION FOR EACH BOGIE.
- 10 WIDE CATERPILLAR TRACK. ONE-PIECE ELASTOMER MOLDING.
- 11 PLOW (OPTIONAL; OPERATION BY THIRD SERVO).

- 1 Fungerande varningslampa är extra tillbehör och ingår i tillbehörssatsen.
- 2 Kaross av klar stark lexan plast.
- 3 Avgasröret ingår endast i tillbehörssatsen.
- 4 Fartreglage som styr respektive motor vid styrning.
- 5 Chassie av lådtype skyddar mekanik och radioinstallation.
- 6 Dubbla motorer och växellådor för respektive band.
- 7 Plats finns om så önskas för två ack-paket.
- 8 Fartkontroll som styr hastigheten fram/back.
- 9 Varje hjul som stöder bandet är separat avfjädrat.
- 10 De breda drivbanden är gjutna i sektioner.
- 11 Skrapan (plojen) ingår i tillbehörssatsen och styrs av en tredje kanal på radion.

OBS! TILLBEHÖRSSATSEN SÄLJS SEPARAT.

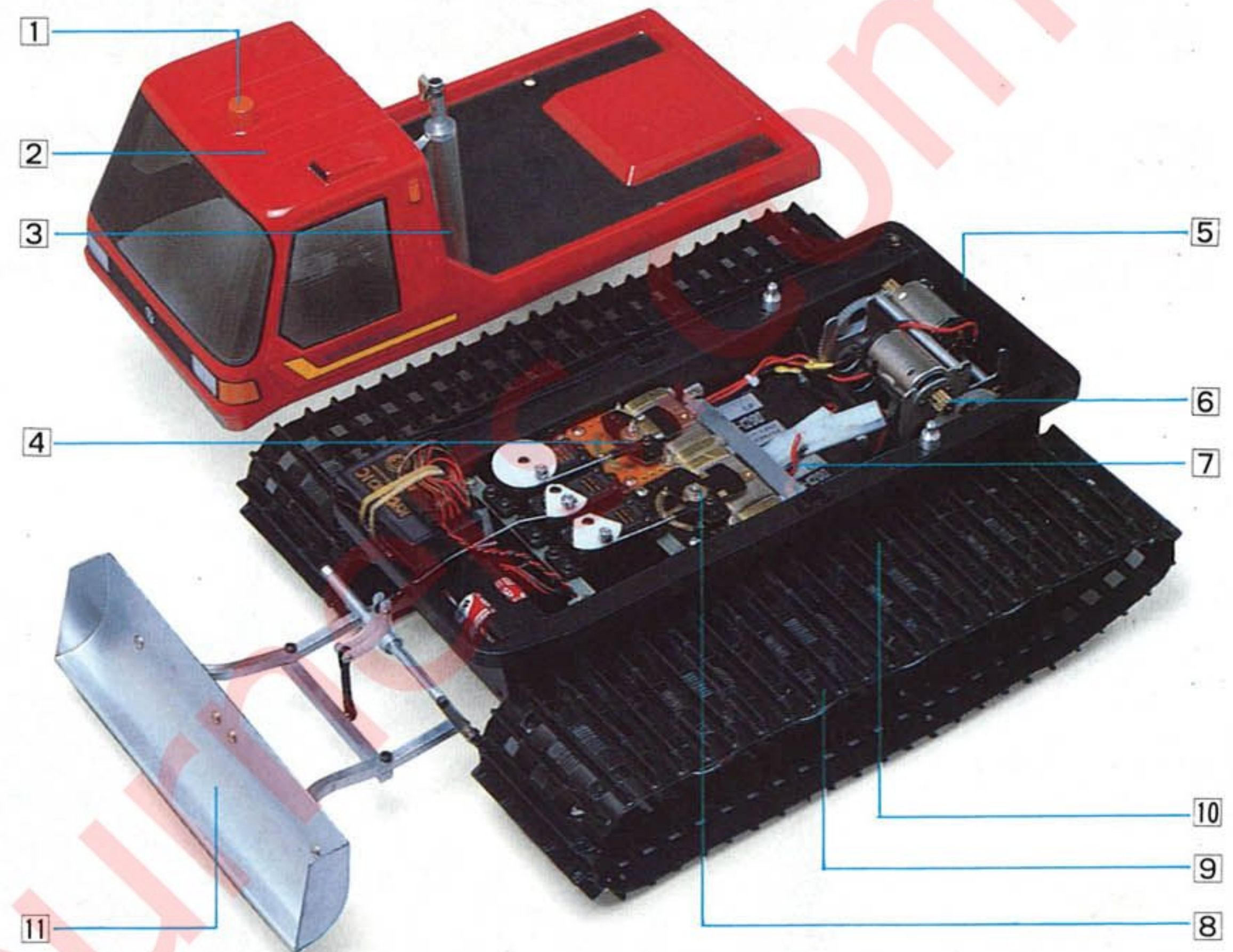

CAN BE OPERATED ON ALMOST ANY SURFACE. SAND, SNOW, ICE, OR GRASS ARE NO PROBLEM. POWERFUL ENOUGH TO CLIMB A 45° SLOPE!

Drivningen via banden medger möjlighet till att klara stigningar upp till 45 grader både i snö och sand.



BOGIE INDEPENDENT SUSPENSION PASSES SMOOTHLY OVER IRREGULARITIES. ENDLESS CATERPILLAR-TYPE TRACK SPREADS WEIGHT AND GRIPS ANY SURFACE.

För att banden skall följa underlaget perfekt är varje stödhjul separat avfjädrat.

SPECIAL RACING BUGGIES

■ FORD RS200 ■ TOYOTA SUPRA ■ STINGER MKII
■ BURNS 4WD ■ FANTOM 21-4iS ■ ASSAULT

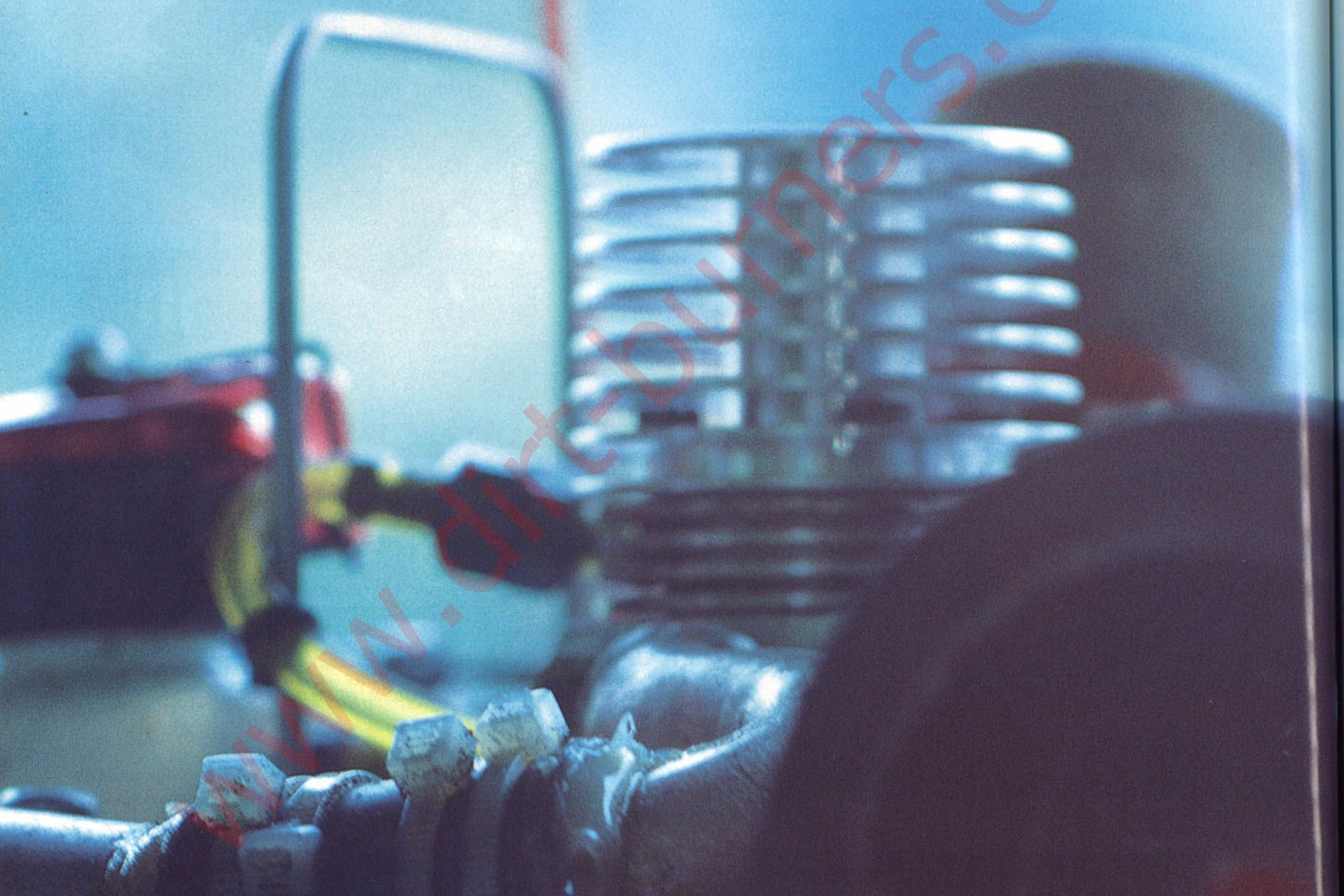

ENGINE POWERED VEHICLES

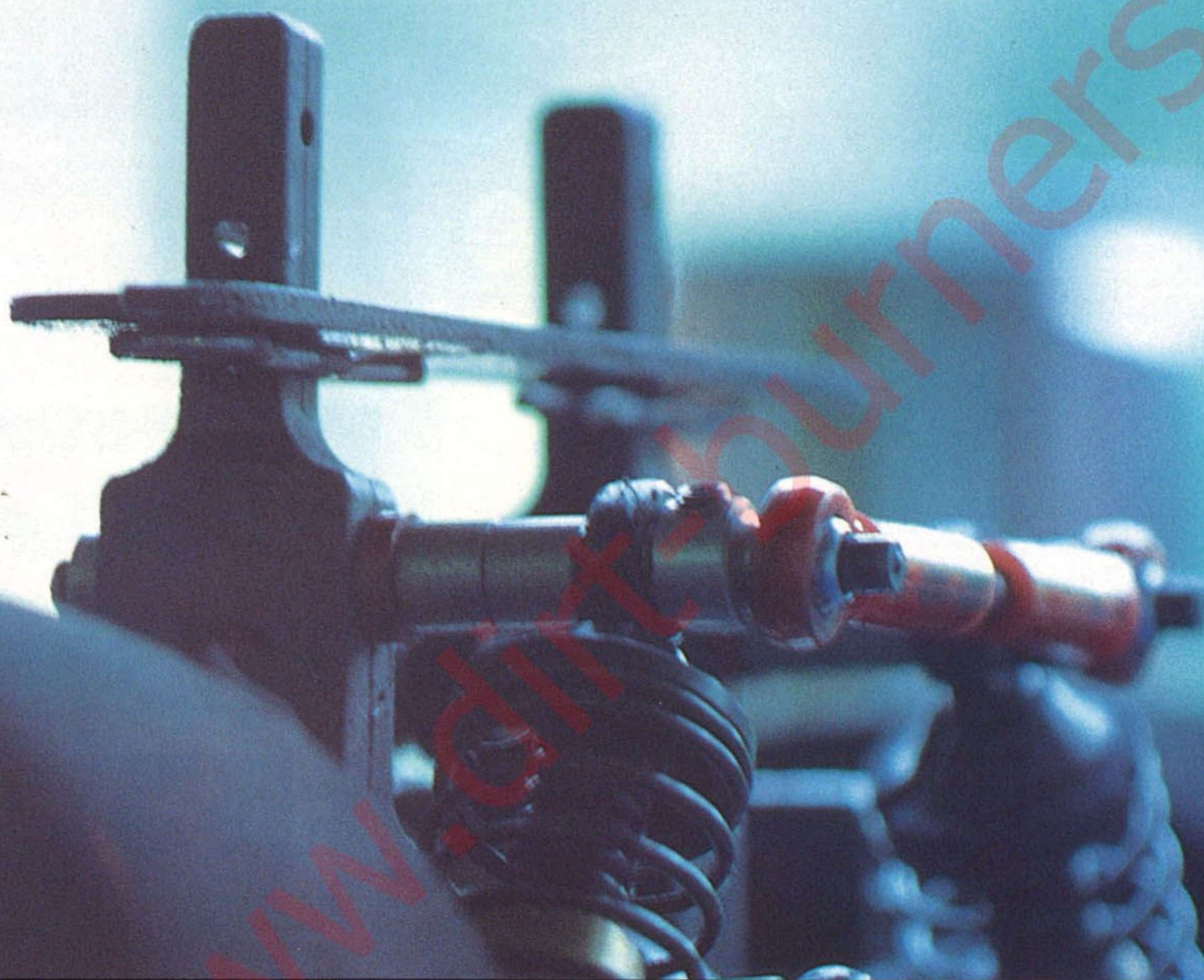

	Name	Scale	Length	Height	Weight	Suspension	Shock Absorbers	Ball Bearings	Engine	Drive System	Potential For Hop-up*
2WD	ASSAULT	1 : 10	460mm	160mm	1480g	(F) TS; (R) TS	4 Oil-filled	(Not included)	O.S. CZ-1	—	△
4	FORD RS-200	1 : 10	370mm	120mm	1600g	(F) WS; (R) WS	4 Oil-filled	4 PCS.	O.S. 10FP-B	Shaft	○
	TOYOTA SUPRA	1 : 10	370mm	120mm	1600g	(F) WS; (R) WS	4 Oil-filled	4 PCS.	O.S. 10FP-B	Shaft	○
W	STINGER MK-II	1 : 10	370mm	110mm	1450g	(F) WS; (R) WS	4 Oil-filled	5 PCS.	.11 Class (not included)	Belt	◎
D	BURNS 4WD	1 : 8	420mm	160mm	3200g	(F) WS; SP (R) WS	4 Oil-filled	18 PCS.	.21 Class (not included)	Shaft	◎
	FANTOM 21-4iS	1 : 8	515mm	130mm	2650g	(F) WS; (R) WS	3 Oil-filled	14 PCS.	.21 Class (not included)	Belt	◎

(F)=FRONT, (R)=REAR, WS=DOUBLE WISHBONE or WISHBONE/PARALLEL ARM, TS=TRAILING ARM, SS=SLIDING PILLAR * ◎High, ○Moderate, △Low

FORD RS-200

RADIO CONTROLLED 1/10 ENGINE POWERED 4WD RALLY CAR
 1/10スケール ラジオコントロール 10エンジン 4WDラリーカー
フォードRS-200



GREAT FUN AND EASY STARTING!

WHICH IS THE BEST FEATURE OF THESE GREAT-PERFORMING, ACCURATE-SCALE RALLY CARS? THE HIGH PERFORMANCE? OR THE EASY STARTING? BOTH HAVE AN ALL-INDEPENDENT LONG-TRAVEL SUSPENSION WITH OIL-FILLED SHOCKS MUCH LIKE THAT OF KYOSHO'S WINNING OPTIMA. BOTH HAVE FOUR-WHEEL DRIVE THROUGH SCALE RADIAL-PATTERN TIRES. THE EASY STARTING? BY RECOIL STARTER. JUST A PULL OR TWO AND THE POWERFUL O.S. 10FP-B(K) ENGINE IS RUNNING. TWO PRIMING PUMPS BUILT IN FOR QUICK STARTING IN ANY WEATHER, HOT OR COLD. RUNNING THESE EXCITING VEHICLES IS JUST ABOUT AS EASY AS AN ELECTRIC, BUT A LOT MORE FUN! THE ENGINE GIVES A REALISTIC SOUND, BUT THE CUSTOM MUFFLER (SUPPLIED) KEEPS IT VERY QUIET. POWER GOES THROUGH A CENTER DIFFERENTIAL TO THE TWO FORE-AND-AFT SHAFTS AND TOOTHED BELTS TO THE FRONT AND REAR DIFFS. IT'S SIMPLE AND EFFICIENT. ASSEMBLY IS EASY BECAUSE ALL THE DRIVE COMPONENTS ARE FACTORY MOUNTED ON THE RIGID ALUMINUM CHASSIS.

REQUIRED FOR OPERATION/RECOMMENDED FOR BEST APPEARANCE (NOT INCLUDED)

- RADIO CONTROL SET (TWO-CHANNEL) ●FUEL ●D-SIZE ALKALINE CELL ●POLYCA COLOR PAINT
- MICRON LINE STRIPING TAPE

Technical Data

- ①Length/355mm (14") ②Width/240mm (9.4") ③Height/120mm (4.7") ④Wheelbase/270mm (10.6") ⑤Ground clearance/25mm (1.0") ⑥Front track/205mm (8.1") ⑦Rear track/205mm (8.1") ⑧Weight/1660g (3.7 lb) ⑨Tires (F/R) $\phi 77 \times 36$ mm
 ⑩Engine/O.S. 10FP-B(K) (Included/with recoil starter, custom muffler, battery holder, and priming fuel tank) ⑪Gear ratio/12:1 ⑫Radio control set Two-channel (not included)

DRÖMT OM ATT BLI EN RALLYFÖRARE?

Får vi i så fall presentera en FORD RS-200 i miniformat? Delvis förmonterad och försedd med en 1.6 cc förbränningsmotor. Och med prestanda som gör att få rallybilar hänger med! I varje fall upp till 40 km/timmen. Det här handlar om en liten racer med mycket av chassiekomponenterna hämtade från välkända Optima-familjen och förstås med fyrhjulsdrift och tredubbla differentier. Superenkel att starta genom den inbyggda startapparaten och en choke pump för motorn. Det här är också den perfekta första bilen för Dig som vill prova på förbränningsmotor. Supertuff rallykaross.

DET HÄR BEHÖVS FÖRUTOM BYGGSATSEN

En tvåkanals radio är faktiskt allt!

FORD RS-200

10 ENGINE POWERED 4WD RALLY CAR
No. 3013

TOYOTA SUPRA

10 ENGINE POWERED 4WD RALLY CAR
No. 3014

1:10 SCALE

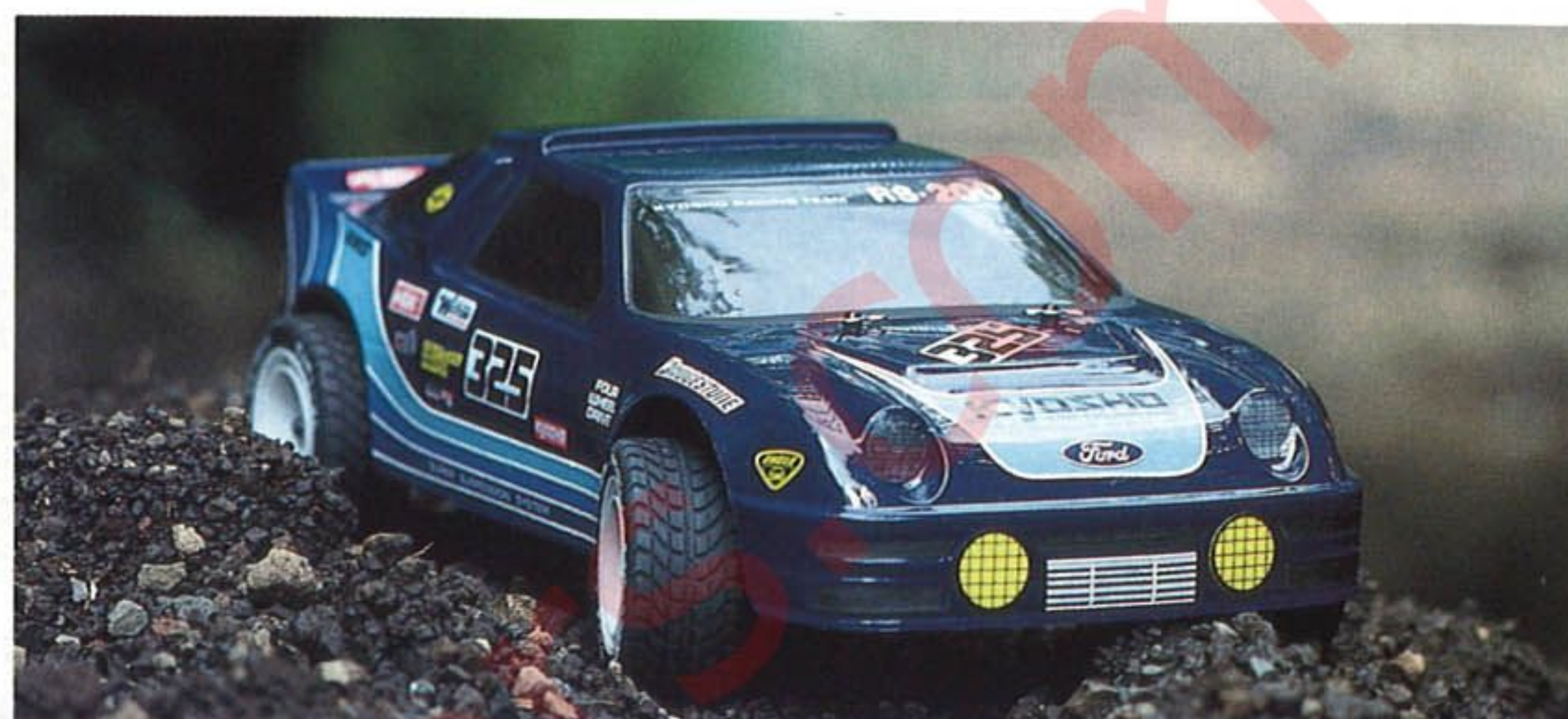

- 1 SCALE RADIAL-PATTERN TIRES.
- 2 GEAR-TYPE DIFFERENTIAL.
- 3 FUEL TANK WITH BUILT-IN PRIMING PUMPS (INCLUDED).
- 4 ENGINE (O.S.10FP-B(K): INCLUDED)
- 5 CUSTOM SUPER-SILENT MUFFLER (INCLUDED).
- 6 LIGHTWEIGHT, SCALE WHEEL.
- 7 LONG-TRAVEL WISHBONE ARM REAR SUSPENSION.
- 8 DRIVE BELTS TRANSMIT POWER FROM DRIVE-SHAFTS TO F/R DIFFS.
- 9 RECOIL STARTER (INCLUDED).
- 10 ALLOY-ALUMINUM CHASSIS PLATE.
- 11 DRIVESHAFT TRANSMITS POWER FROM ENGINE TO FRONT AND REAR.
- 12 EFFECTIVE OIL-FILLED SHOCK ABSORBER.
- 13 LONG-TRAVEL WISHBONE ARM FRONT SUSPENSION.
- 14 STRONG, PROTECTIVE FRONT BUMPER.

- 1 Mönstrade riktiga gummidäck.
- 2 Drevdifferentialer fram och bak.
- 3 Bränsletank med inbyggd choke-pump.
- 4 Specialutvecklad OS motor med inbyggd startapparat.
- 5 Mycket effektiv ljuddämpare för tyst men realistisk gång.
- 6 Lätta skalariktiga fälgar.
- 7 Långa starka bärramar.
- 8 Tandremmar för effektiv drivning av differentialerna.
- 9 Den inbyggda startapparaten.
- 10 Chassieplatta av flygaluminium.
- 11 Rak drivaxel som överför kraften från motorn.
- 12 Riktiga oljestötdämpare runt om.
- 13 Långa bärramar för bästa väghållning.
- 14 Kraftig stötdämpare.

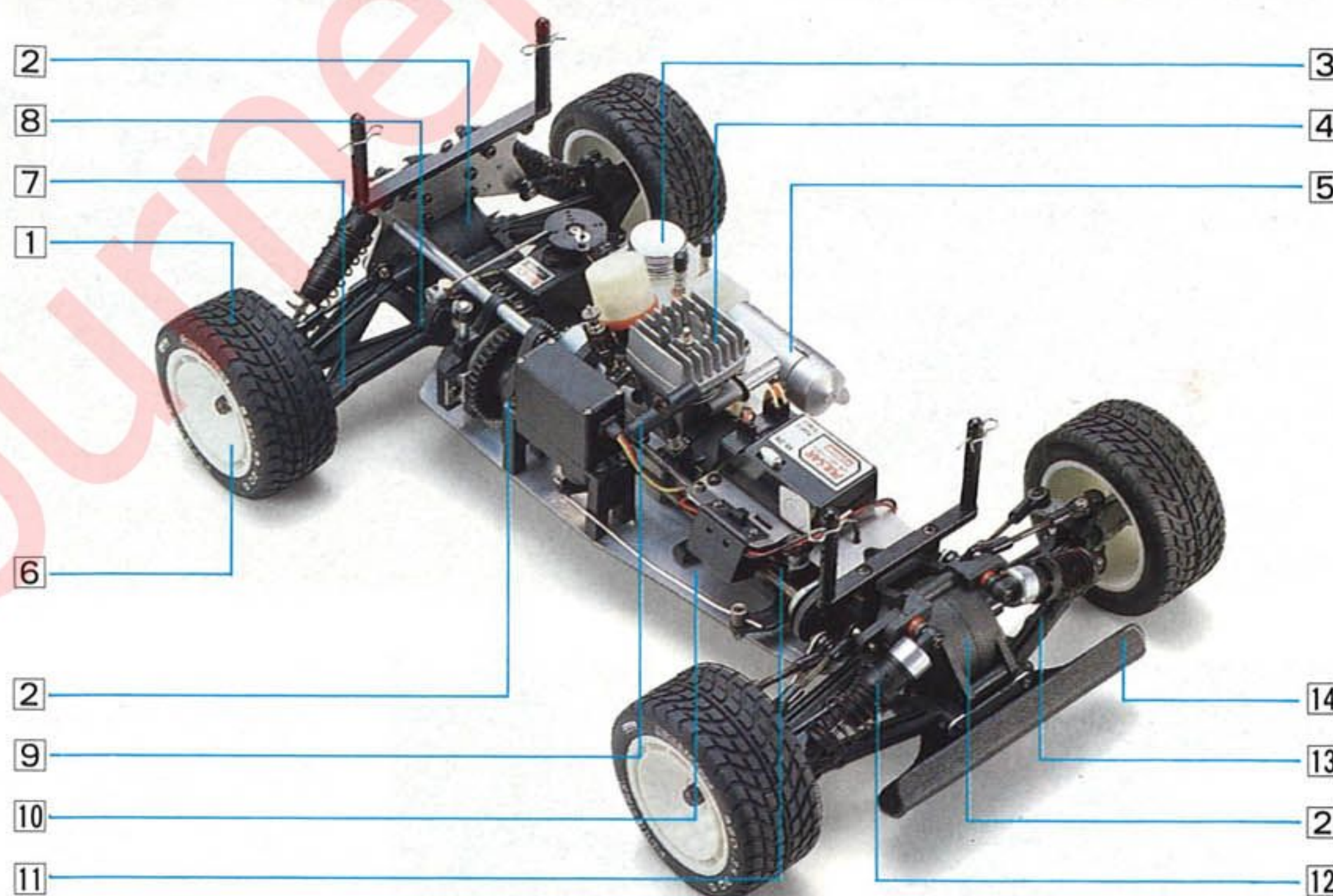

LONG-TRAVEL PARALLEL WISHBONE/ARM SUSPENSION FRONT AND REAR WITH EFFECTIVE OIL-FILLED SHOCK ABSORBERS SOAKS UP BUMPS AND KEEPS THE RS-200 ON COURSE TO THE WINNING FLAG! EQUALLY AT HOME ON SMOOTH ROADS AND ROUGH TRACKS.

Det mesta av hjulupphängningarna är hämtat från Optima-serien vilket borgar för bästa tänkbara väghållning.



TOOTHED BELTS DRIVE THE FRONT/REAR WHEELS VIA F/R DIFFERENTIALS. (THERE IS A THIRD "TRANSFER BOX" DIFF AT THE MAIN GEAR.)

Motorn från OS är speciellt utvecklad för den här modellen. Drivningen sker via ett kraftigt nylondrev från kopplingen.

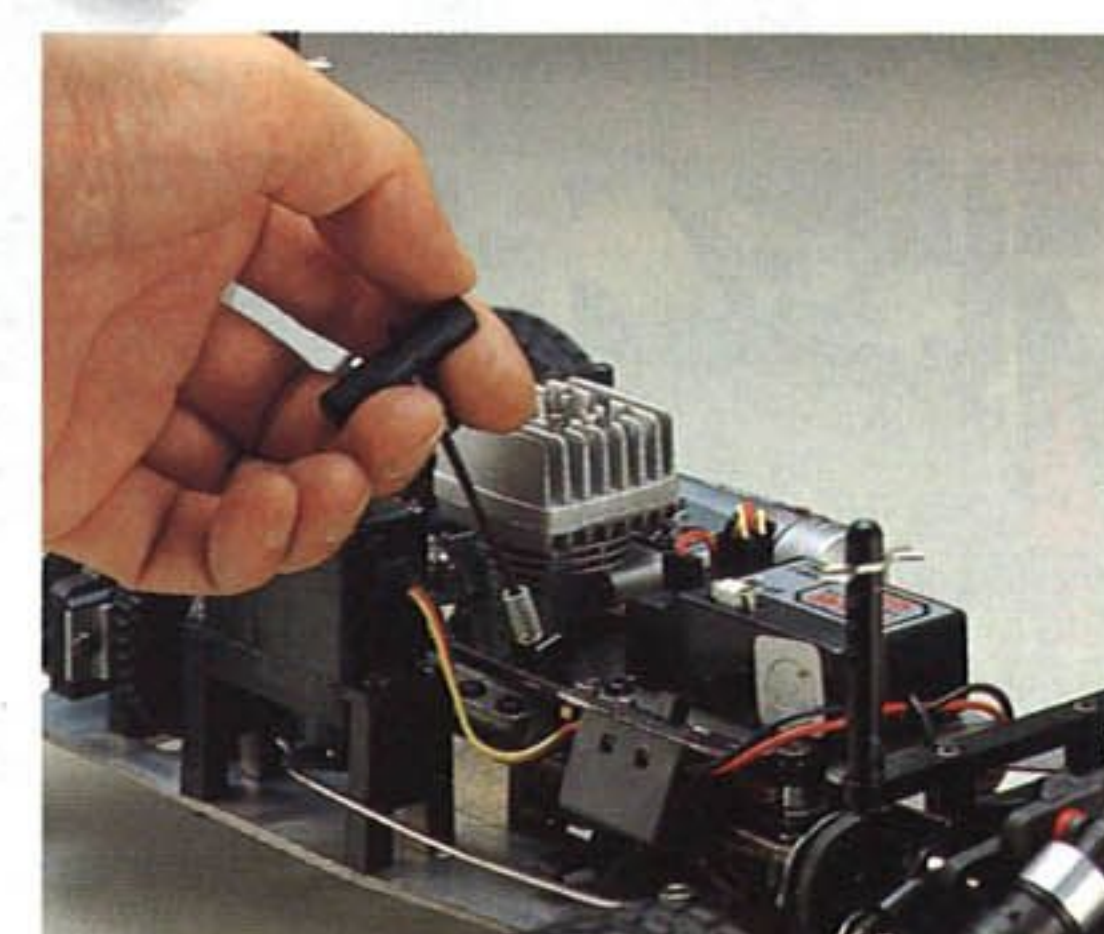

RECOIL STARTER (A KYOSHO EXCLUSIVE) MAKES STARTING SUPER SIMPLE! JUST ONE OR TWO PULLS AND THE ENGINE IS RUNNING!

CIRCUIT 1000 SERIES STINGER MK-II

10 ENGINE POWERED OFF-ROAD RACING BUGGY

1:10 SCALE
No. 3042



NEW SOPHISTICATION IN .10 BUGGIES!

- ① ULTRA-LOW PROFILE PIN-SPIKE TIRES FOR DEPENDABLE TRACTION ON ANY SURFACE.
- ② MUFFLER (INCLUDED IN KIT) GIVES GOOD SILENCING WITH LOW POWER LOSS.
- ③ ENGINE MOUNTS ACCEPT ALMOST ANY .09-.11 GLOW ENGINE.
- ④ STRONG REINFORCED DRIVE BELT IS LIGHT, RELIABLE AND EFFICIENT.
- ⑤ OVERSIZE OIL-FILLED SHOCK ABSORBER.
- ⑥ NYLON "ROLL OVER" BUMPER.
- ⑦ REAR DIFFERENTIAL FEATURES 5 BALL BEARINGS FOR LOW POWER LOSS, HIGH RELIABILITY.
- ⑧ FOUR-WHEEL INDEPENDENT SUSPENSION WITH STRONG, LIGHT EX66 NYLON DOUBLE WISHBONES.
- ⑨ STRONG, LIGHT 17S ALUMINUM IPAN-TYPE CHASSIS.
- ⑩ NYLON RADIO PLATE.
- ⑪ EX66 NYLON WISHBONE / PARALLEL ARM FRONT SUSPENSION.
- ⑫ STYLISH METALIZED NYLON WHEELS.

NOUVELLE SOPHISTICATION EN BUGGYS

RACER FÖR 2 CC MOTOR

Stinger MK II är en racer i samma skala som Optima-familjen men med den skillnaden att elmotorn bytts ut mot en förbränningsmotor på ca 2 cc (t ex OS CZ-II). Den gör tillsammans med den väl utprovade chassiekonstruktionen (Optima) att en Stinger faktiskt går "som ett skållat troll" och lämnat mer än en av sina bröder i den större skalan 1:8 efter sig. Den mindre skalan (1:10) gör den lätt att bära med sig mellan körningarna. Du startar den med den inbyggda startapparaten och ett speciellt starthandtag. Chassie av aluminium, oljestötdämpare, kromade fälgar och mycket mer. Mycket roligt för ett rimligt pris!

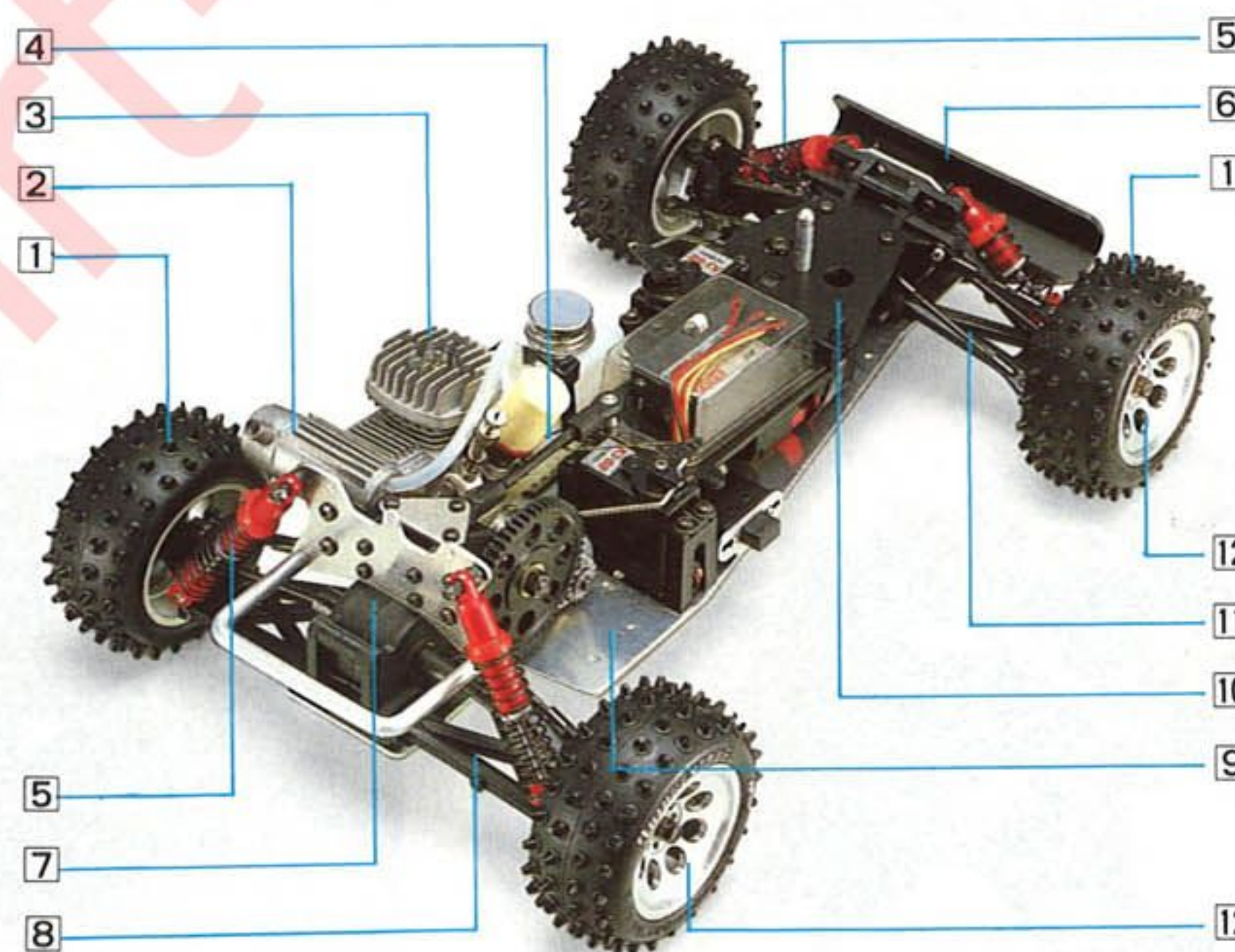
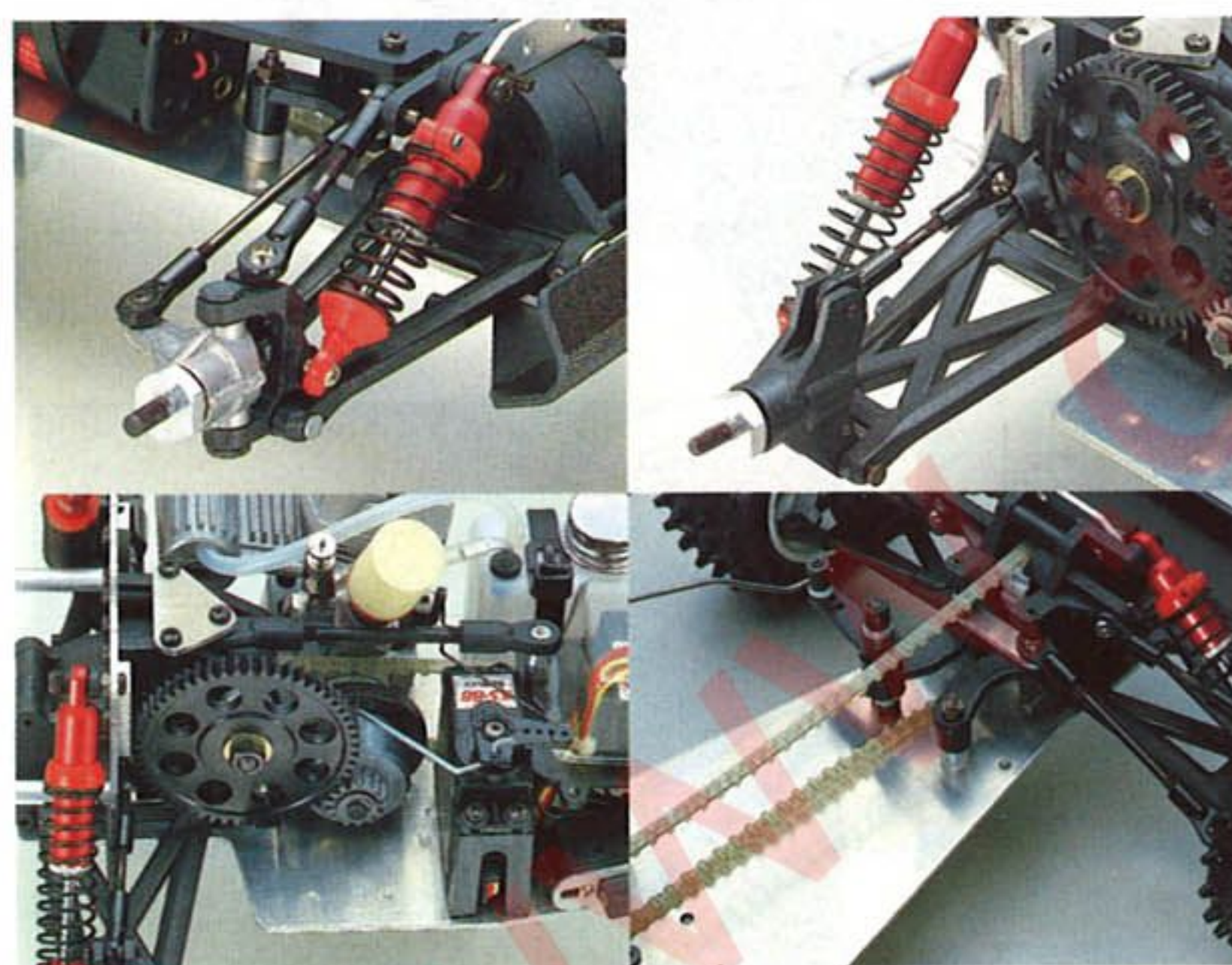

REQUIRED FOR OPERATION/RECOMMENDED FOR BEST APPEARANCE (NOT INCLUDED)

● RADIO CONTROL SET (TWO-CHANNEL) ● ENGINE (.09-.11) ● FUEL, BATTERY, ETC. ● STARTER ● POLYCA COLOR PAINT ● MICRON LINE STRIPING TAPE

Technical Data

① Length/370mm (14.6in) ② Width/240mm (9.5in) ③ Height/110mm (4.3in) ④ Wheelbase/275mm (10.8in) ⑤ Ground Clearance/30mm (1.2in) ⑥ Front Track/200mm (7.9in) ⑦ Rear Track/205mm (8in) ⑧ Tires/(F)φ85×37mm; (R)φ85×37mm ⑨ Total Weight/1450g (3.2lb) ⑩ Engine/.11 class (Not included) ⑪ Radio/Two-channel (Not included)

DET HÄR BEHÖVS FÖRUTOM MOTORN

En tvåkanals radio, en motor på ca 2 cc samt glödströmutrustning.

CIRCUIT 1000 SERIES ASSAULT

10 ENGINE POWERED OFF-ROAD RACER

1:10 SCALE

No. 3095



ENGINE-POWER PERFORMANCE WITH ELECTRIC-POWER CONVENIENCE.

- WIDE BUMPER IS DOUBLE-PURPOSE, HOLDS GLOW-PLUG CELL.
- STRONG DIE-CAST ALUMINUM TRAILING-ARM SUSPENSION AND COIL-SPRING/OIL-FILLED SHOCKS FOR TOP ROADHOLDING.
- RACING-DEVELOPED ALLOY-ALUMINUM LADDER-TYPE FRAME.
- PROTECTIVE RADIO BOX FOR RECEIVER AND BATTERIES.
- PUSH-BUTTON AUTO-PRIME FUEL TANK.
- FACTORY-ASSEMBLED GEAR BOX/DIFFERENTIAL UNIT.
- ZIP/PULL-CORD/ELECTRIC STARTER COMBINATION START SYSTEM.
- SPECIAL O.S. CZ ENGINE STARTS EASILY, REQUIRES NO ADJUSTMENTS.
- MUFFLER, FILTER, GLOW PLUG, STARTER CONE, ZIP AND ROPE INCLUDED.

ASSAULT SÄLJS INTE LÄNGRE I SVERIGE. VI REKOMMENDEAR ATT DU TITTAR NÄRMARE PÅ DE BÅDA FYRHJULSDRIVNA MODELLERNA STINGER MK II & FORD RS-200 PÅ FÖREGÅENDE SIDOR.

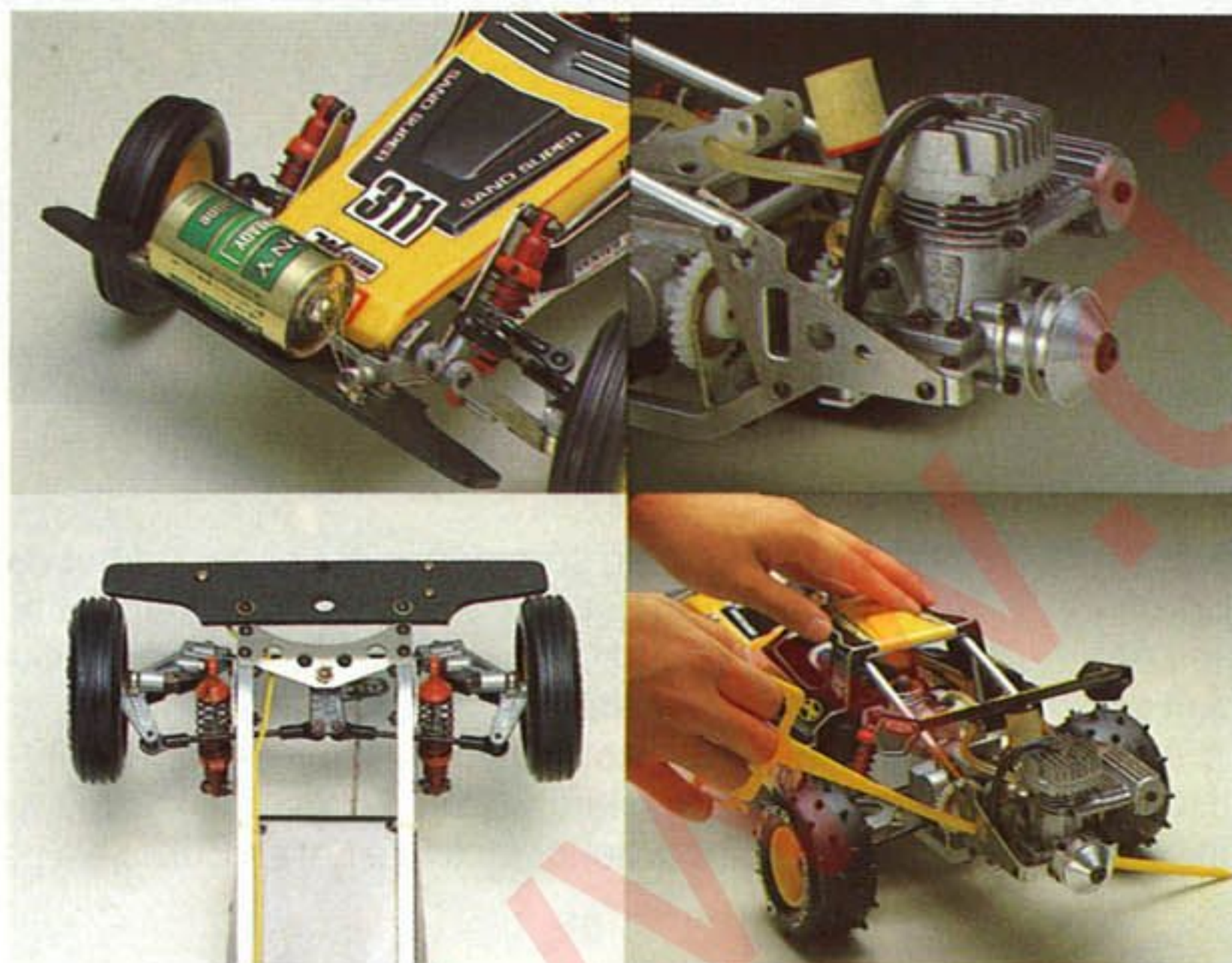

REQUIRED FOR OPERATION/RECOMMENDED FOR BEST APPEARANCE (NOT INCLUDED)

● RADIO CONTROL SET (TWO-CHANNEL) ● FUEL ● D-SIZE ALKALINE CELL ● POLYCA COLOR PAINT ● MICRON LINE STRIPING TAPE

Technical Data

① Length/460mm (18.0in) ② Width/230mm (9.0in) ③ Height/135mm (5.3in) ④ Wheelbase/270mm (10.6in) ⑤ Ground Clearance/30mm (1.2in) ⑥ Front Track/182mm (7.2in) ⑦ Rear Track/186mm (7.3in) ⑧ Tires / (F) ϕ 73 \times 18mm; (R) ϕ 90 \times 40mm ⑨ Total Weight 1480g (3.25lb) ⑩ Engine / O.S.CZ 12BB (Included) ⑪ Radio / Two-channel (Not included)



THE MOST ADVANCED .21-CLASS OFF-ROADER ON THE MARKET!

THE TRACK BURNER! IN ITS FIRST YEAR, *BURNS* TOOK 2ND AND 4TH PLACES AT THE IFMAR OFF-ROAD WORLD CHAMPIONSHIPS (ITALY, 1988). EVERY FEATURE IS DESIGNED FOR PERFORMANCE. THREE STRONG METAL-GEAR DIFFERENTIALS AND SHAFT DRIVE TO GET ALL THE POWER TO THE FRONT AND REAR WHEELS FOR MAXIMUM TRACTION AND ACCELERATION. LONG-TRAVEL, DOUBLE-WISHBONE SUSPENSION AND SUPERB OIL-FILLED SHOCK ABSORBERS TO KEEP *BURNS* ON COURSE AND TRACKING THROUGH CORNERS WHATEVER THE TRACK CONDITIONS. RIGID 17S ALLOY ALUMINUM-PLATE CHASSIS. TOP-QUALITY GLASS-REINFORCED MOLDED NYLON PARTS. SPECIAL MANIFOLD, MUFFLER, AND 18 BALL BEARINGS INCLUDED.

REQUIRED FOR OPERATION/RECOMMEND FOR BEST APPEARANCE (NOT INCLUDED)

●RADIO CONTROL SET (TWO-CHANNEL) ●ENGINE (.21 CLASS) ●FUEL, BATTERY, ETC. ●STARTER ●POLYCA COLOR PAINT ●MICRON LINE STRIPING TAPE

Technical Data

①Length/420mm (16.5in) ②Width/300mm (11.8in) ③Height/160mm (6.3in) ④Wheelbase/320mm (12.6in) ⑤Ground Clearance/45mm (1.8in) ⑥Front Track/255mm (10.0in) ⑦Rear Track/255mm (10.0in) ⑧Tires (F)φ116×42mm; (R)φ116×48mm ⑨Total Weight/3200g-(7.1lb) ⑩Engine/.21-class,(Not included) ⑪Radio/Two-channel (Not included)

RACING I DEN "TUNGA" KLASSEN

Etta och två i kvalet, två och fyra i finalen på VM i Italien sommaren -88 säger en hel del om kapaciteten hos en Burns 4WD. Kyosho har i den här skalan koncentrerat sig på att göra en enda modell - en vinnare! Burns har ärvt en hel del ideer från de framgångsrika Optima-bilarna men mycket är också helt nytvecklade i denna fullracer. En väl sammansatt Burns i händerna på en duktig förare är en svårslagen kombination. Trots det är den inte svårare att bygga än att lite erfarenhet från de mindre bilarna räcker. Valet av material är väl genomtänkt och det finns dessutom mycket racingtillbehör att tillgå. Låt en Burns hjälpa Dig till de stora segrarna.

DET HÄR BEHÖVS FÖRUTOM BYGGSATSEN

En tvåkanals radio med extra starkt styrservo, en 3.5 cc motor samt startutrustning.

BURNS 4WD

21 ENGINE POWERED RACING BUGGY

1:8 SCALE

No. 3096



- 1 NYLON "ROLL OVER" BUMPER.
- 2 SPIKE-PATTERN TIRES FRONT/REAR.
- 3 DOUBLE-WISHBONE FRONT SUSPENSION WITH UNIVERSAL-JOINT HALFSHAFTS.
- 4 PRESSED 17S ALUMINUM PAN-TYPE CHASSIS.
- 5 CUSTOM MUFFLER (INCLUDED IN KIT).
- 6 21-CLASS ENGINE (NOT INCLUDED).
- 7 CUSTOM MANIFOLD (INCLUDED IN KIT).
- 8 DOUBLE-WISHBONE REAR SUSPENSION. (FRONT/REAR FULLY ADJUSTABLE.)
- 9 PRESSURE-TYPE OIL-FILLED SHOCK ABSORBERS FRONT REAR.
- 10 METAL-GEAR TYPE DIFFERENTIAL FRONT/REAR.
- 11 DISC BRAKE.
- 12 TRANSFER CASE TO DIVIDE POWER BETWEEN FRONT AND REAR WHEELS.
- 13 SHAFT DRIVE TO FRONT REAR WHEELS.

- 1 Stötfångare av seg nylon.
- 2 Däck med gummidubbar, smalare fram för minskad friktion.
- 3 Kraftiga bärarmar och drivning via kardanknut till hjulaxeln.
- 4 Chassie av aluminium i flygkvalitet med förstärkningar.
- 5 Ljuddämpare med trycknippel.
- 6 Motorfäste passande OS s k bakblåsmotorer.
- 7 Avgasadapter fram till motorn (för OS).
- 8 Kraftiga bärarmar av glasfylld nylon för maximal styrka.
- 9 Kraftiga tryckoljestötdämpare runt om.
- 10 Differentialer med helmetalldrev.
- 11 Skivbroms för bästa bromsverkan.
- 12 Mellandifferential som fördelar kraften mellan fram & bakvagn.
- 13 Kardanaxel överför kraften från mellandifferentialen.

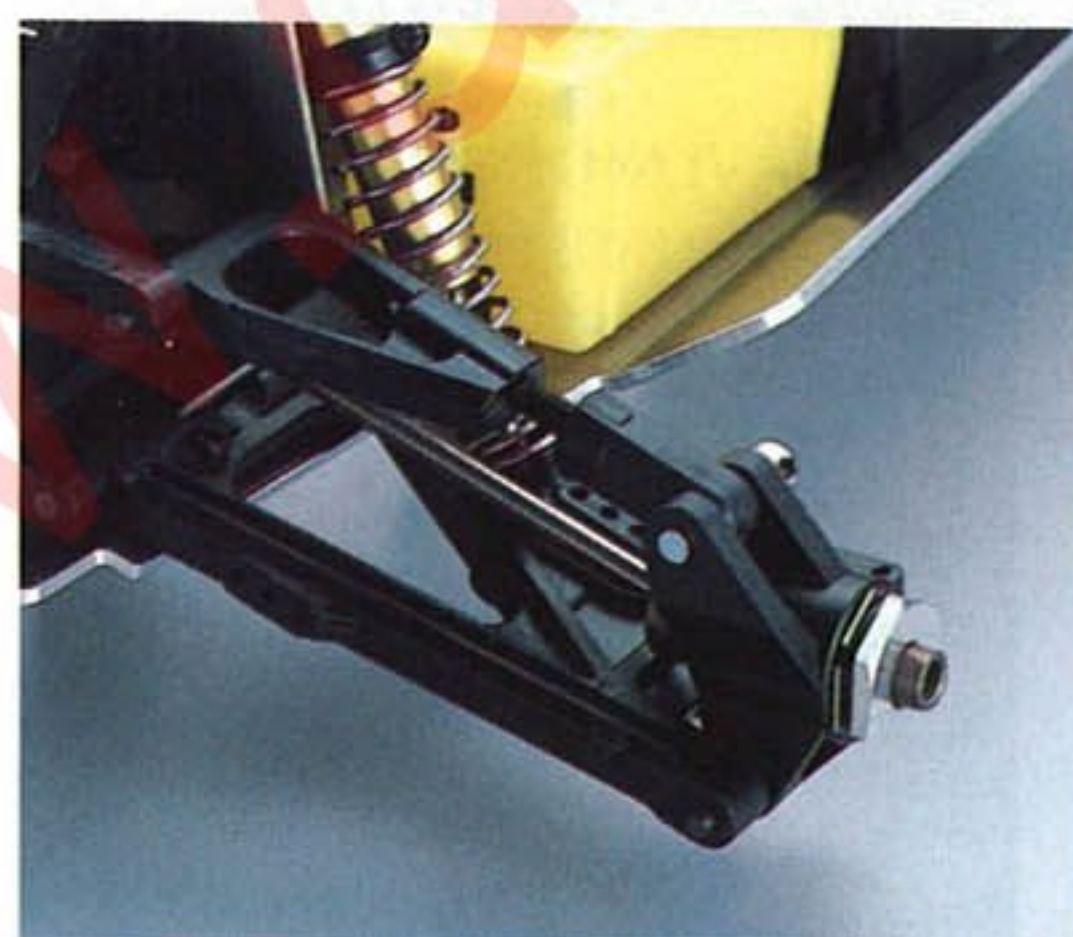
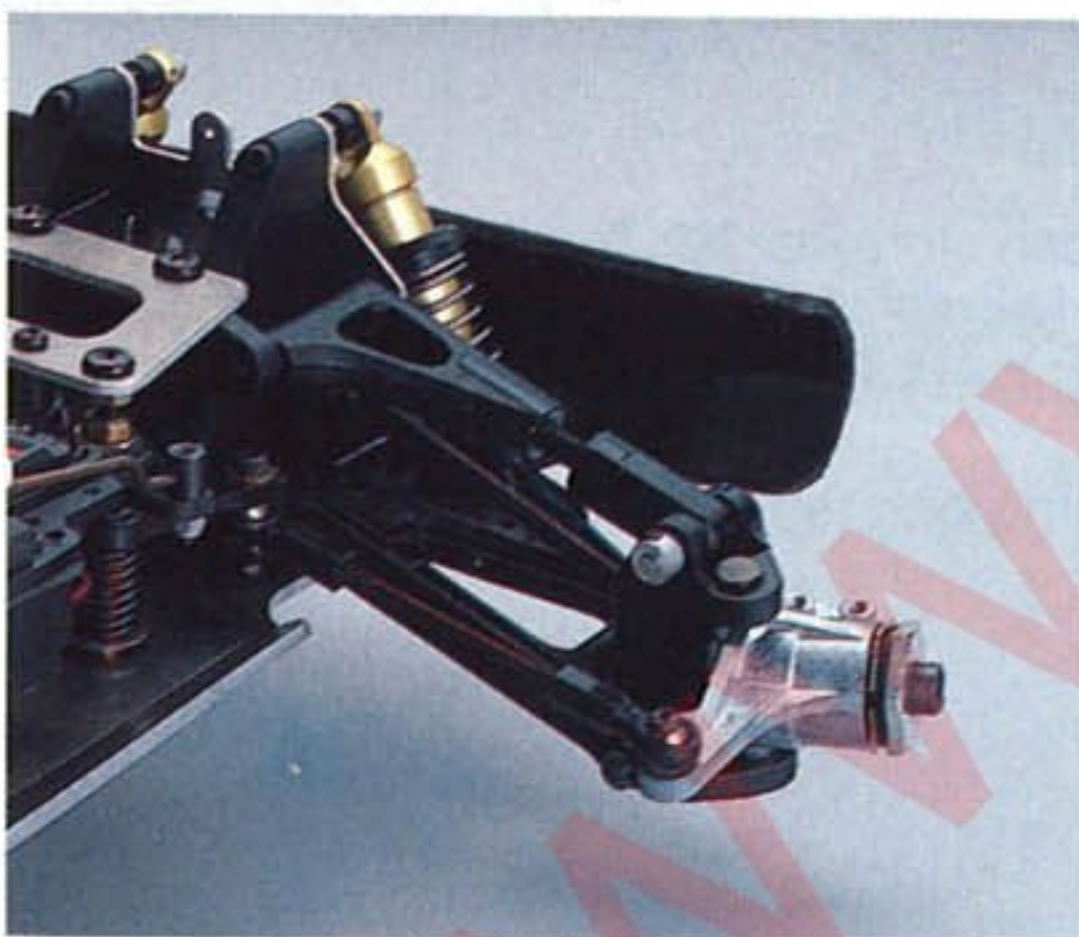
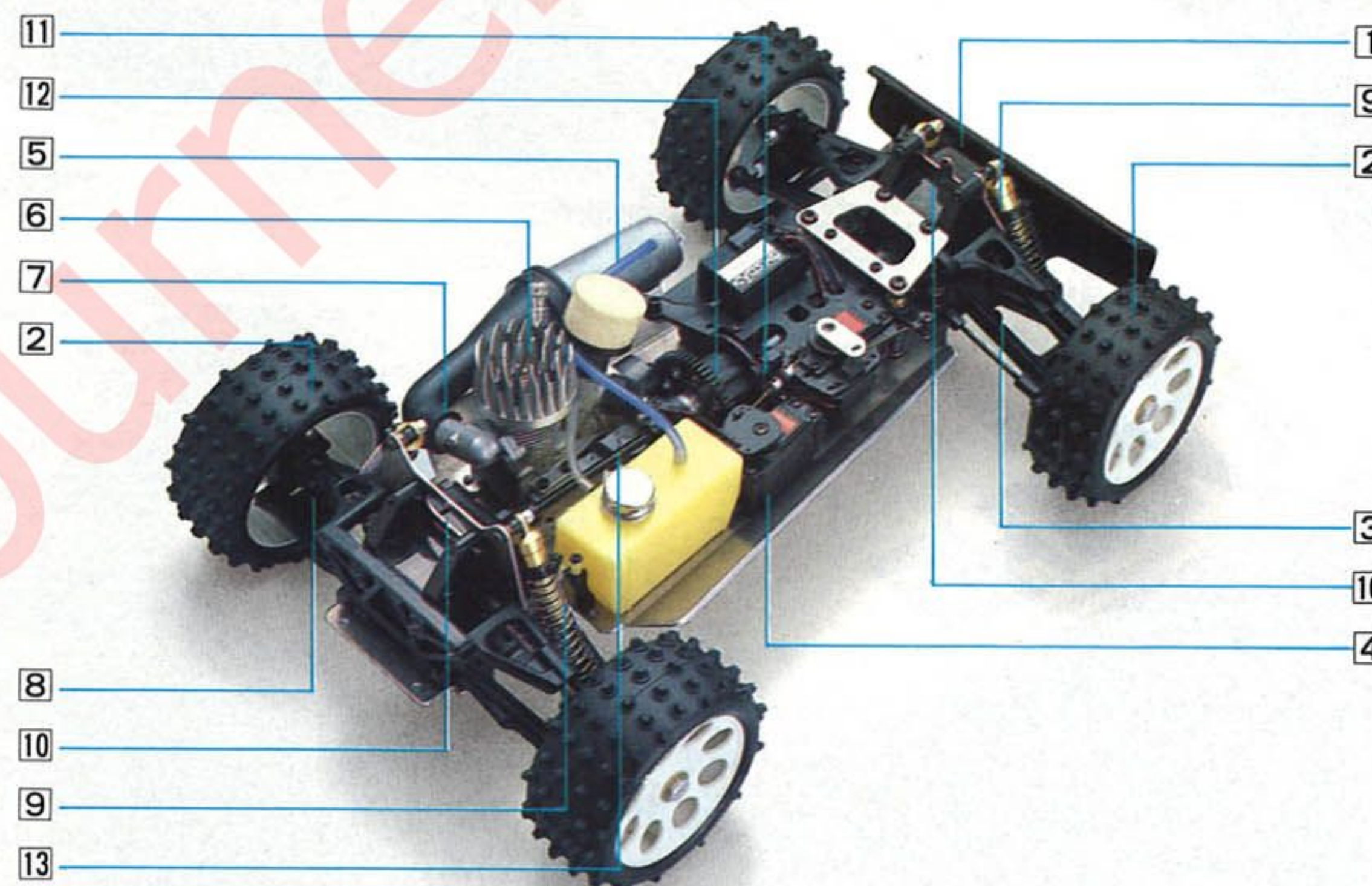

LONG-TRAVEL WISHBONE PARALLEL-ARM FRONT/REAR SUSPENSION GOBBLES UP BUMPS, ASSURES DIRECTIONAL STABILITY. EFFECTIVE SHOCKS. STEEL DRIVESHAFTS FRONT/REAR.

Extremt långa bärarmar och många justeringsmöjligheter är tillsammans med s k GULD-stötdämpare några av hemligheterna bakom den fantastiska väghållningen.

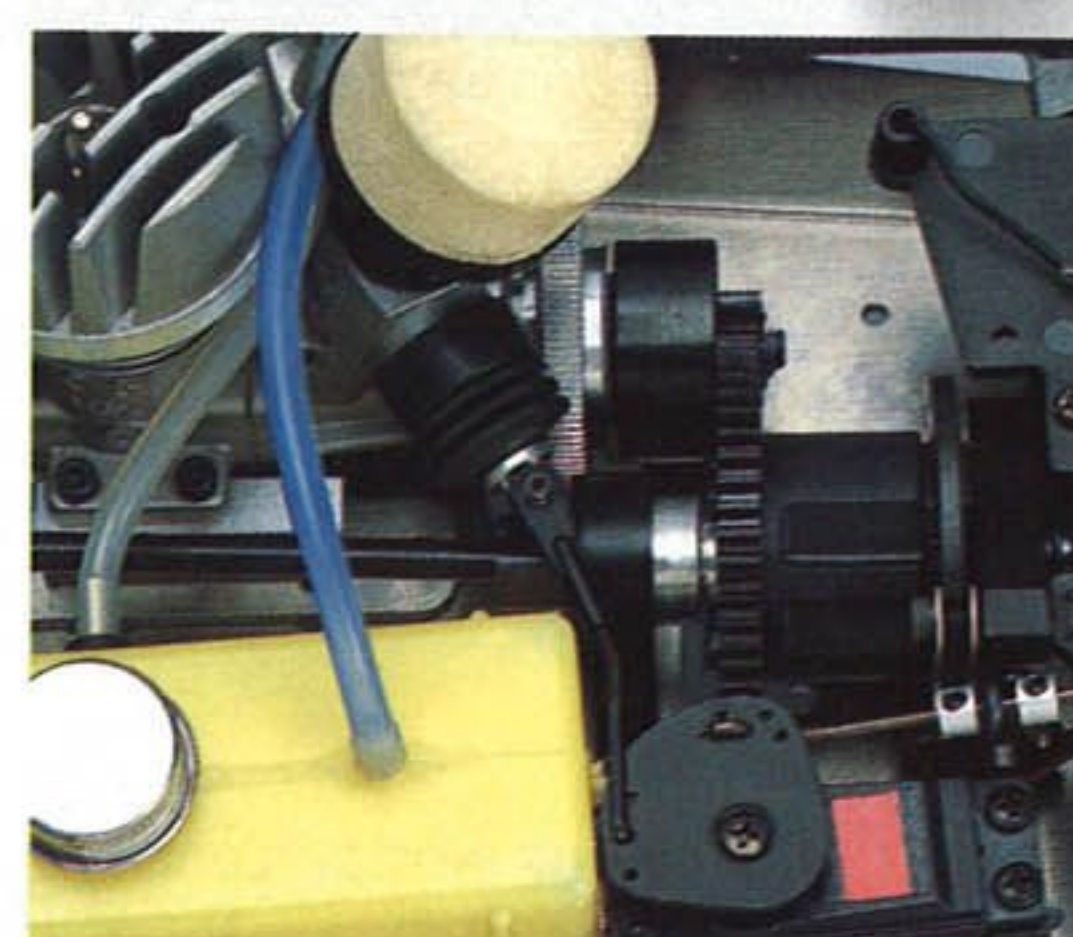

TRANSFER CASE SPLITS POWER TO FRONT AND REAR DRIVE WHEELS VIA DRIVE SHAFTS.

Smart montering av gas/broms servot ger minimal längd på linkaget.

EXTRA TILLBEHÖR FÖR BURNS

Det finns en lång rad racingtillbehör som t ex frästa drev, vinge med vingfäste, krängningshämmare, en hel serie däck för olika underlag och mycket mer.

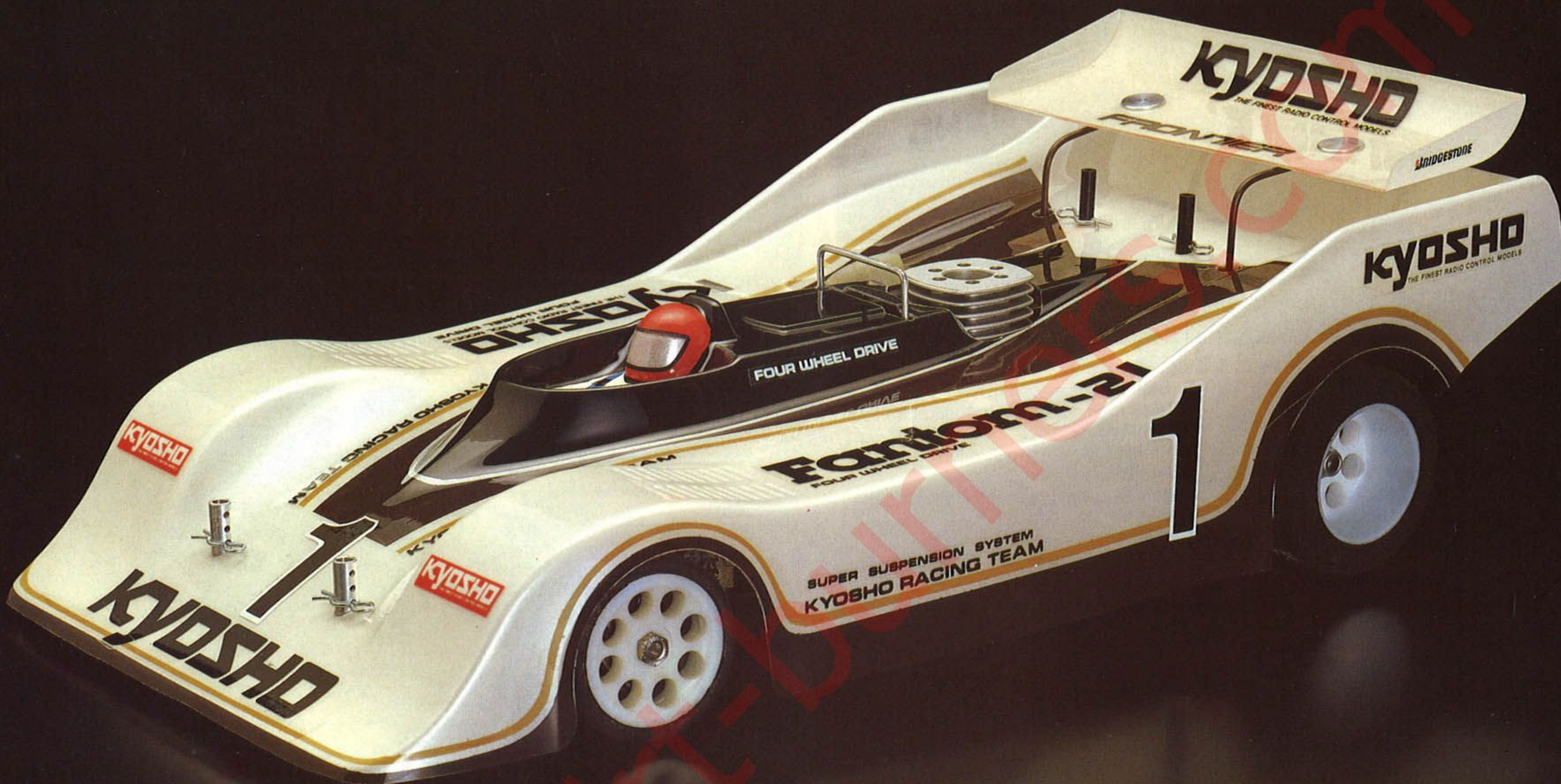

THE ALL-OUT COMPETITOR!

FIRST CHOICE FOR BEATING THE COMPETITION! FOUR-WHEEL DOUBLE-WISHBONE INDEPENDENT SUSPENSION. FOUR-WHEEL DRIVE VIA TWO DIFFERENTIALS AND LIGHT, RELIABLE TOOTHED DRIVE BELT. STIFF ALUMINUM ALLOY CHASSIS. STRONG GLASS-REINFORCED SUSPENSION PARTS. TOP-QUALITY OIL-FILLED SHOCK ABSORBERS. ANTI-DIVE, ANTI-ROLL FRONT SUSPENSION. MID-SHIPS/SIDEWINDER ENGINE POSITION FOR BEST BALANCE AND TOP POWER DELIVERY.

REQUIRED FOR OPERATION / RECOMMENDED FOR BEST APPEARANCE (NOT INCLUDED)

●RADIO CONTROL SET (TWO-CHANNEL) ●ENGINE (.21 CLASS) ●FUEL, BATTERY, ETC. ●STARTER ●POLYCA COLOR PAINT ●MICRON LINE STRIPING TAPE

Technical Data

①Length/515mm(20.3in) ②Width/266mm(10.5in) ③Height/130mm(5.1in) ④Wheelbase/307mm(12.1in) ⑤Ground Clearance/10mm(0.4in) ⑥Front Track/210mm(8.3in) ⑦Rear Track/198mm(7.8in) ⑧Tires / (F) $\phi 70 \times 40$ mm; (R) $\phi 80 \times 60$ mm
 ⑨Total Weight/2650g(5.8lb) ⑩Engine/21 class(Not included) ⑪Radio/Two-channel(Not included)

BANTÄVLINGBIL I SKALA 1:8

FANTOM 21-4iS heter tävlingsbanbilen i den stora klassen för motorer på 3.5 cc. Den är fyrhjulsdriven och naturligtvis separat avfjädrad på alla fyra hjulen. En modell byggd endast med ett mål. Nämligen målet att vinna tävlingar.

Fantom importeras endast på beställning och reservdelslager finns för närvarande endast i Japan.

FANTOM 21-4iS

20 ENGINE POWERED RACING CAR

1:8 SCALE

No. 3121



- ① DOUBLE WISHBONES FRONT/REAR.
- ② LARGE OIL-FILLED SHOCKS (3).
- ③ EFFICIENT TOOTHED DRIVE BELT.
- ④ STIFF ALLOY ALUMINUM CHASSIS.
- ⑤ DIFFERENTIAL (FRONT/REAR).
- ⑥ ANTI-ROLL BAR.

- 1 Dubbla bärarmar för varje hjul separat avfjädrade med oljestötdämpare och spjäl-fjädrar.
- 2 Kraftiga oljestötdämpare
- 3 Drivning mellan fram och bakvagn via tandrem (stål-cord).
- 4 Chassie och radioplatta av aluminium i flygkvalitet.
- 5 Differentialer både fram och bak.
- 6 Krängningshämmare finns både fram och bak.

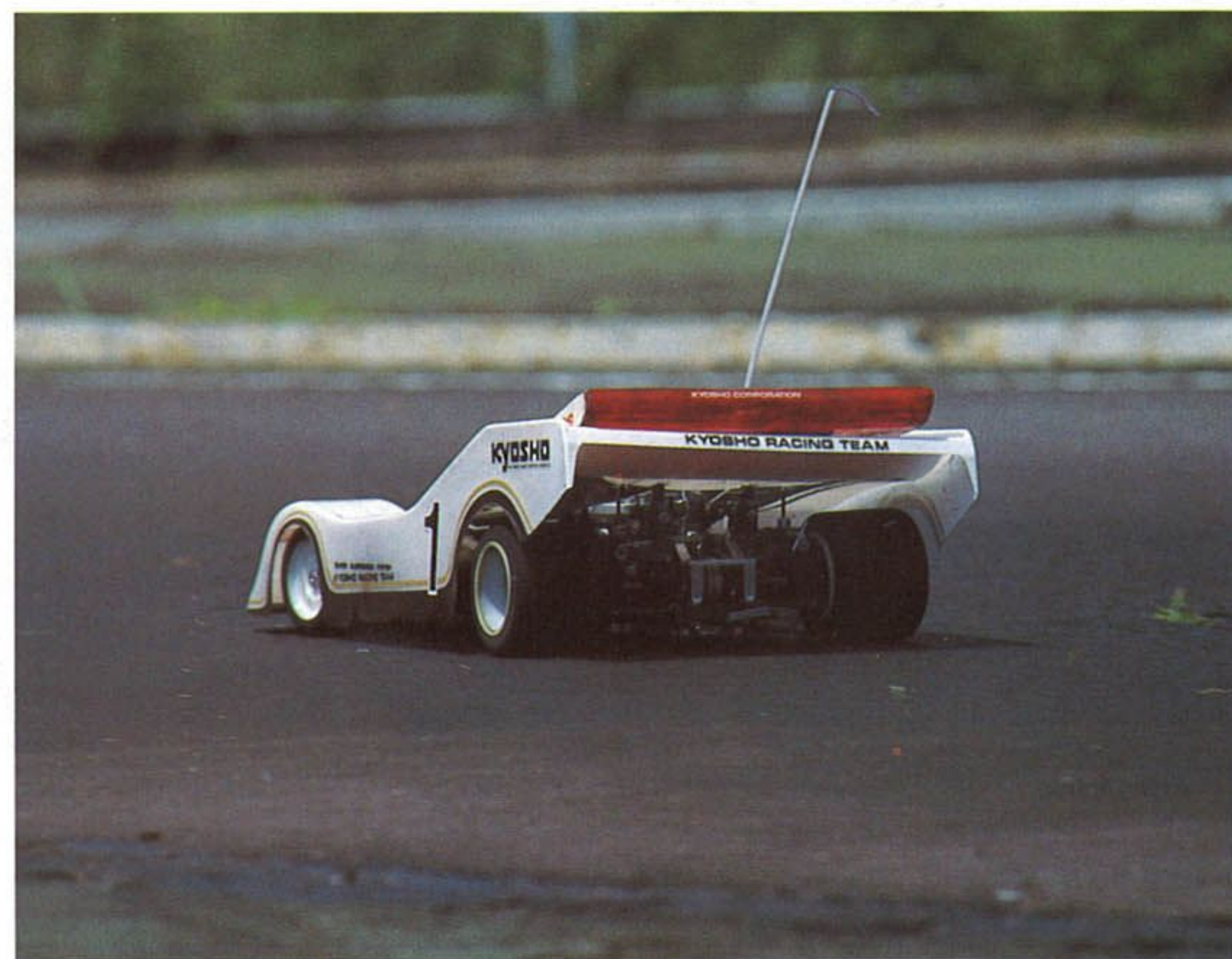
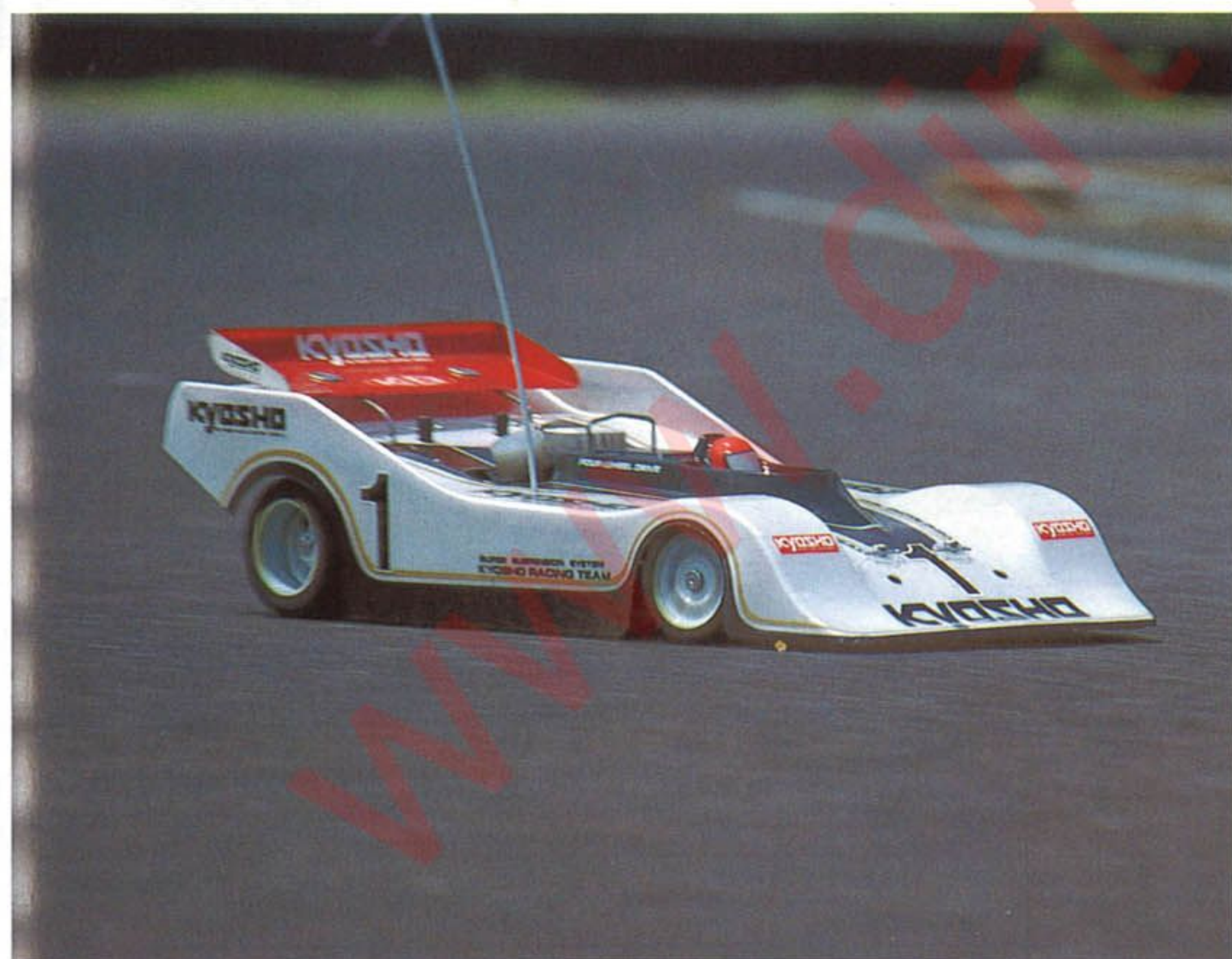
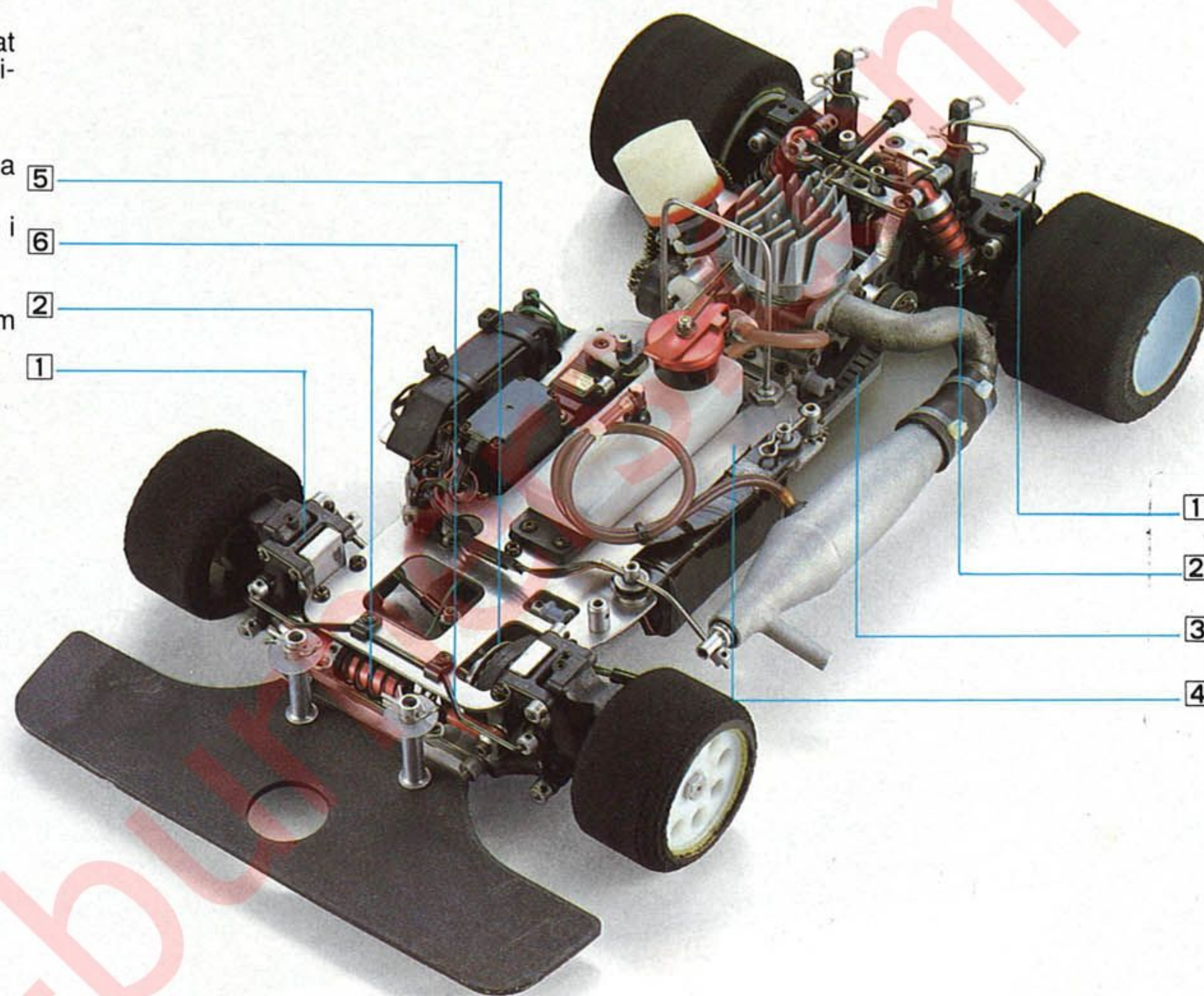

POWER

■ BATTERIES ■ CHARGERS
■ MOTORS

SUPER NICKEL-CADMIUM FAST-CHARGE BATTERIES

KYOSHO NICKEL-CADMIUM (NiCd) BATTERY PACKS ARE DESIGNED SPECIFICALLY TO DELIVER THE HIGH OUTPUT CURRENTS REQUIRED FOR MODEL MOTORS. THEY CAN ALL BE RECHARGED IN ABOUT 15 MINUTES USING AN APPROPRIATE KYOSHO CHARGER. NiCd BATTERIES CAN BE RECHARGED UP TO 500 TIMES UNDER GOOD CONDITIONS.

KVALITETS ACK-PAKET FRÅN KYOSHO

Alla ack-paket från Kyosho är av ni-cad typ och av hög kvalitet för alla tåla hård användning och för att tåla många uppladdningar. En väl skött ack går att ladda om upp till 500 gånger! En del typer av ack-paket, t ex det s k 7.2V/1200mAh, förekommer i flera olika versioner. Generellt kan sägas att en dyrare ack både ger längre körtid, högre toppfart och längre livslängd. Välj själv efter Dina behov!

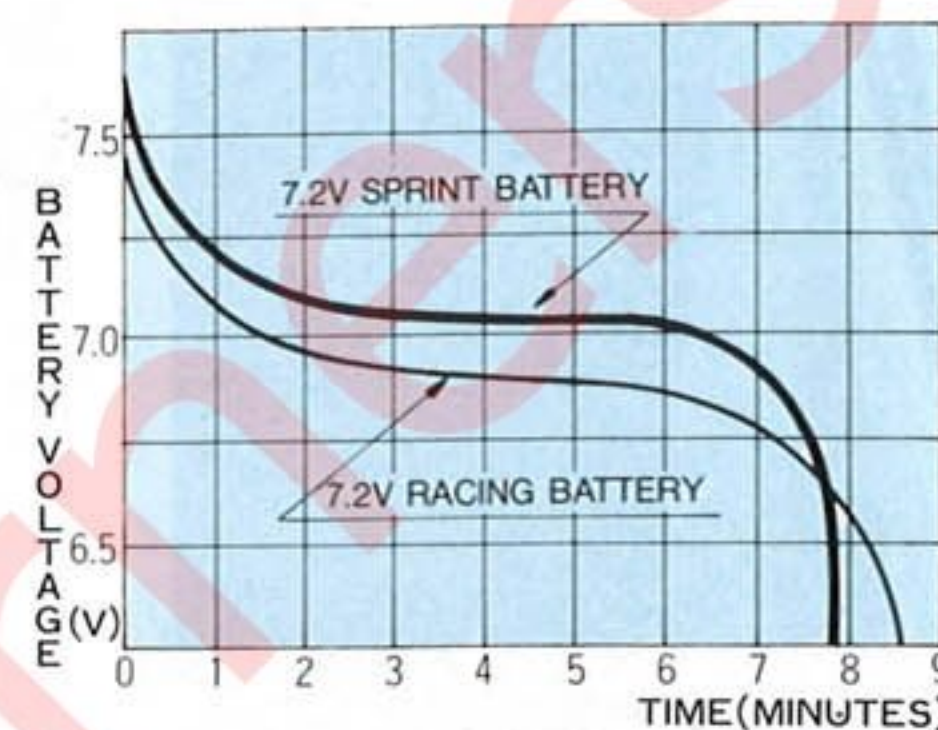

SPECIAL LOW-IMPEDANCE DESIGN CELLS FOR MINIMUM VOLTAGE DROP, MAXIMUM CURRENT AND POWER. THE BEST CHOICE FOR FAST SPRINT RACES. CAN BE FAST CHARGED. SILICONE RUBBER INSULATION. SPARE CONNECTOR INCLUDED. THE PREMIUM POWER SOURCE!

Kurvorna till vänster visar spänningen under urladdning för den nya SPRINT acken respektive den vanliga RACING. Välj en SPRINT när Du vill ha hög spänning för racing.

■ 7.2V SPRINT BATTERY [7.2V-1200mAh] No.2310



FOR ALL APPLICATIONS REQUIRING 7.2V POWER. CAN SUPPLY HIGH CURRENT FOR RACING WITHOUT OVERHEATING. FOR SPORTS AND PERFORMANCE.

Det här är en bra ack för allmänt bruk där lite extra kraft och kapacitet önskas.

■ 7.2V RACING BATTERY [7.2V-1200mAh] No.2218



FOR ALL SPORTS APPLICATIONS REQUIRING 7.2V POWER. (USE SPRINT SCR OR RACING TYPE FOR COMPETITION.) FOR CARS, BOATS & SPORTS ELECTRIC AIRCRAFT.

POWER heter det vanliga standardbatteriet som Du oftast väljer till Din första modell. Levereras med adapterkabel som gör att det passar de flesta fabrikat.

■ 7.2V POWER BATTERY [7.2V-1200mAh] No.2306



■ 7.2V-1700mAh SPEED NiCd BATTERY No.2330E

SPECIAL CELLS WITH LOW INTERNAL RESISTANCE FOR MAXIMUM CURRENT OUTPUT AND POWER. HIGH 1700mAh CAPACITY FOR 8-MINUTE ROAD RACES. SILICONE INSULATED LEADS. SPARE MATCHING CONNECTOR INCLUDED.

Det här är det mest moderna ack-paketet och de som används av de flesta som tävlar och av de som vill ha max körtid. Kapaciteten är hela 1700 mAh trots att formatet är samma som för 7.2V/1200mAh acken.

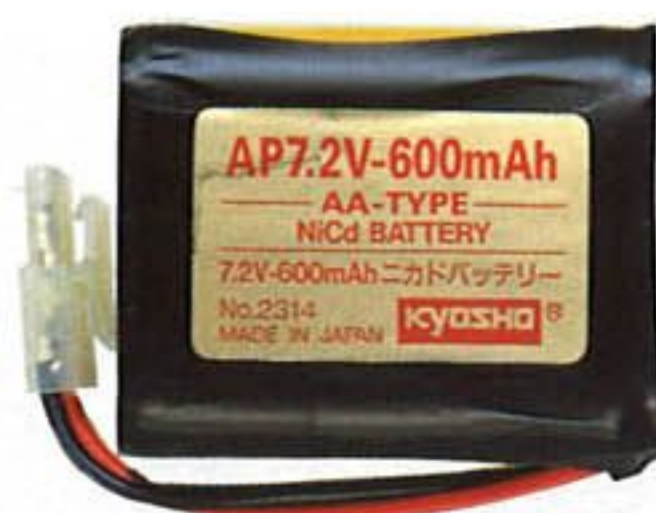

■ 7.2V-600mAh NiCd BATTERY No.2314

FOR ELECTRIC AIRCRAFT MODELS USING A 7.2V-600mAh NiCd PACK. WITH ONE OR TWO EXTRA PACKS, NEARLY-CONSTANT FLYING IS POSSIBLE. WITH SILICONE INSULATED LEADS AND SPARE MATCHING CONNECTOR. ALSO USABLE IN No.3002 MOTORCYCLES.

Det här ett flyg-ackpack på 7.2V/600mAh.



■ 7.2V-1200mAh SPORTS BATTERY No.2361

FOR "SPORTS" APPLICATIONS, WITH MODERATE CURRENT REQUIREMENTS, SUCH AS BOATS AND NON-RACING CARS. GOOD POWER WITH ECONOMY. (FOR MAXIMUM CURRENT AND POWER, USE #2310 OR #2218.) SPARE MATCHING CONNECTOR INCLUDED.

SPORT är det billigaste ack-paketet och det fungerar mycket bra i alla nybörjarsammanhang.



■ 8.4V POWER BATTERY [8.4V-1200mAh] No.2307

EXCELLENT GENERAL PURPOSE 8.4V NiCd POWER SOURCE. LONG LIFE, HIGH POWER FOR ALL SPORTS APPLICATIONS. (FOR RACING, USE 8.4V TURBO.)

Det här är det välkända POWER paketet i 8.4V utförande. Används t ex i JetStream och i "storhjulningarna".

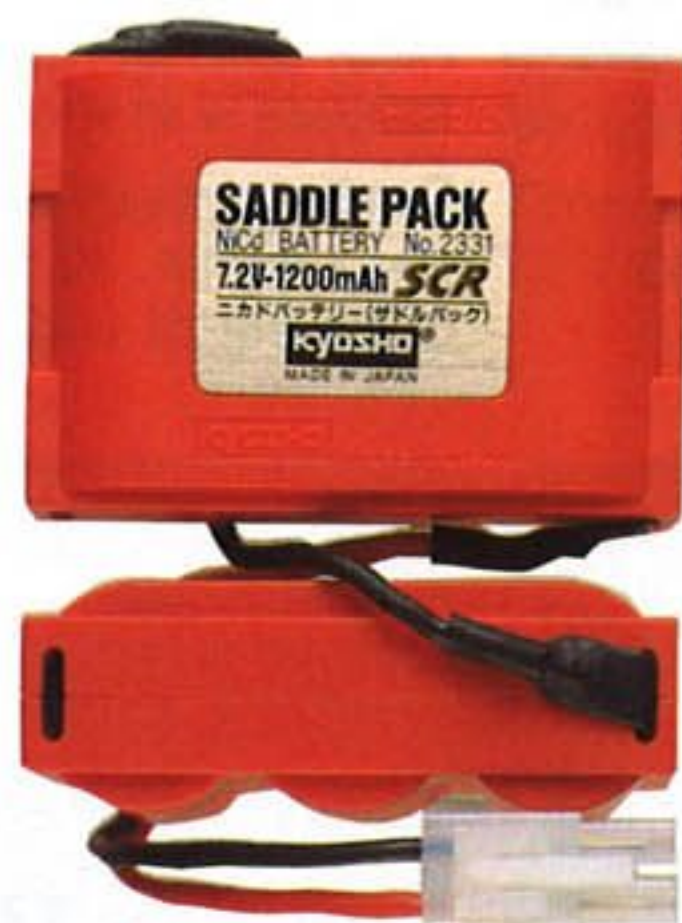

■ 7.2V-1200mAh SPRINT SCR SADDLE PACK NiCd BATTERY No.2331

SPECIAL CELLS WITH LOW INTERNAL RESISTANCE FOR MAXIMUM CURRENT OUTPUT AND POWER. "SADDLE PACK" TWIN CASES FOR LOWEST POSSIBLE MOUNTING AND CG. PROTECTIVE PLASTIC CASES PREVENT SHORT CIRCUITING, ALLOW COOLING. SILICONE INSULATED LEADS SPARE MATCHING CONNECTOR INCLUDED.

Den här SPRINT/SCR acken i sadle-pack utförande för Axis och vissa Optima.



■ 8.4V TURBO RACING BATTERY [8.4V-1200mAh] No.1932

THE MOST POWERFUL BATTERY FOR THE MOST POWERFUL CARS AND BUGGIES! CAN DELIVER MAXIMUM CURRENT FOR RACE-WINNING PERFORMANCE WITHOUT OVERHEATING OR DAMAGE.

Det här är RACING acken i 8.4V utförande. Användes som ovan.

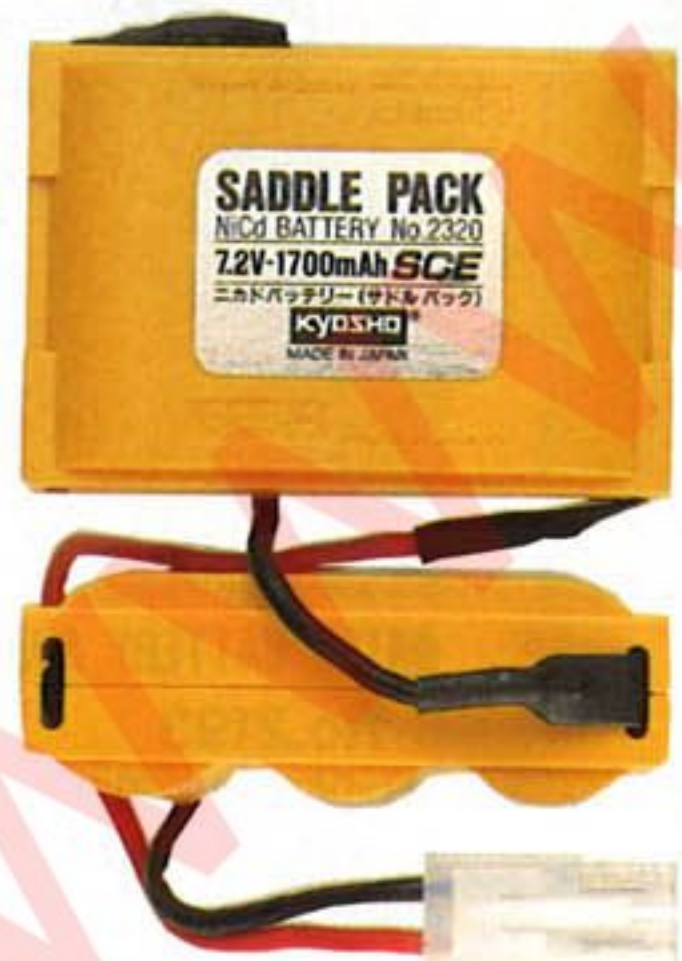

■ 7.2V-1700mAh SCE SADDLE PACK NiCd BATTERY No.2320

SPECIAL CELLS WITH LOW INTERNAL RESISTANCE FOR MAXIMUM CURRENT OUTPUT AND POWER. HIGH 1700mAh CAPACITY FOR 8-MINUTE ROAD RACES. "SADDLE PACK" STYLE FOR LOWEST POSSIBLE CG. PROTECTIVE PLASTIC CASES PREVENT SHORT CIRCUITING, ALLOW COOLING. SILICONE INSULATED LEADS. SPARE MATCHING CONNECTOR INCLUDED.

Det här är SPEED/SCE acken i sadle-pack utförande för Axis och vissa Optima.



■ 6V-1200mAh NiCd BATTERY No.2201

SÄLJS EJ I SVERIGE



■ 6V-450mAh NiCd BATTERY No.2205

FOR USE AS EXTRA POWER SUPPLY FOR ELECTRIC AIRCRAFT MODELS USING 6V-450mAh NiCd PACKS. WITH ONE OR TWO PACKS, ALL-DAY NEARLY-CONSTANT FLYING IS POSSIBLE.

Flyg ackpaket för Petit-serien på 6.0V/450mAh.

BATTERY CHARGERS

■ AC CHARGERS

KYOSHO AC-TYPE NiCd BATTERY CHARGERS ARE MAINLY FOR THE JAPANESE MARKET (100VAC), BUT THEY CAN BE USED WITH HIGHER VOLTAGES IF A STEP-DOWN TRANSFORMER (NOT INCLUDED) IS USED.

■ DC CHARGERS

THESE CHARGERS ARE ALL DESIGNED TO RECHARGE QUICK-CHARGE NiCd BATTERY PACKS IN 15 MINUTES (FULLY DISCHARGED PACK; LESS IF PARTIALLY CHARGED) USING A STANDARD 12V CAR BATTERY AS POWER SOURCE. ALL USE A RELIABLE TIMER TO SHUT OFF CHARGING CURRENT AFTER THE REQUIRED TIME. SUPPLIED CONNECTORS ARE FOR KYOSHO NiCd BATTERY PACKS, BUT ANY FAST-CHARGE NiCd PACK CAN BE RECHARGED USING A SUITABLE CONNECTOR. THREE CHARGERS ARE FOR SPECIFIC TYPES OF NiCd PACKS (VOLTAGE AND CAPACITY).

KYOSHO KVALITETSLADDARE

Kyosho tillverkar en hel serie laddare som passar de olika typer av ack-paket som finns. Alla laddare är väl avpassade för respektive ack-paket och levereras med färdiga anslutningskontakter. De flesta typer av nätladdare kan av S-märknings-skäl inte importera till Sverige. Laddarna på höger sida är alla avsedda att anslutas till 12V likström (t ex ett bilbatteri eller en bilbatteriladdare).

Du gör alltid klokt i att välja en laddare av god kvalitet eftersom det betyder längre livslängd på ack-paketen och mindre risk för skadlig överladdning.



Charging
Time
50minutes

■ AC QUICK CHARGER (8.4V-1200mAh) No.1931

FOR FAST CHARGING 8.4V-1200mAh NiCd BATTERY PACKS, BOTH RACING AND POWER TYPES. FULL CHARGE IN 50 MINUTES OR LESS.

SÄLJS EJ I SVERIGE



Charging
Time
5hours

■ AC CHARGER (8.4V-1200mAh) No.2217

CHARGEUR UNIVERSEL POUR TOUS LES BATTERIES NiCad 8.4V-1200mAh RACING OU POWER. RECHARGE MAXIMALE POUR UNE PUISSANCE DE POINTE.

SÄLJS EJ I SVERIGE



Charging
Time
40minutes

■ AC QUICK CHARGER (7.2V-1200mAh) No.2232

FOR RECHARGING ALL 7.2V 1200mAh FAST-CHARGE NiCd PACKS USING AC POWER. FULLY DISCHARGED PACKS RECHARGE IN 40 MINUTES.

Det svenska utförandet skiljer sig från bilden. Laddtid 30 minuter och automatisk övergång till underhållsladdning.



Charging
Time
14hours

■ AC CHARGER (7.2V-1200mAh) No.2221

FOR RECHARGING ALL 7.2V 1200mAh NiCd BATTERY PACKS. (CAN BE USED WITH PACKS OF HIGHER CAPACITY FOR A LONGER CHARGING PERIOD.)

SÄLJS EJ I SVERIGE



Charging
Time
40minutes

■ AC QUICK CHARGER (7.2V-600mAh) No.2345

FOR RECHARGING ALL 7.2V-600mAh FAST-CHARGE NiCd PACKS USING AC POWER. FULLY DISCHARGED PACKS RECHARGE IN 40 MINUTES.

SÄLJS EJ I SVERIGE



■ 12V BATTERY ADAPTOR No.2193

ALL DC CHARGERS PLUG INTO THE CIGARETTE LIGHTER SOCKET OF A CAR. THIS ADAPTOR ALLOWS DIRECT CONNECTION TO THE BATTERY FOR CONVENIENCE AND LOWER POWER LOSS IN THE CAR WIRING.

SÄLJS EJ I SVERIGE



Charging
Time
15minutes

**DC QUICK CHARGER (6V-450mAh)
No.2365**

FOR 6V-450mAh ELECTRIC AIRPLANE NiCd PACKS. FACTORY PRE-SET CURRENT. AUTO SHUT-OFF. USES 12V CAR BATTERY.

Timerladdare avsedd för ack-paket på 6V/450mAh.

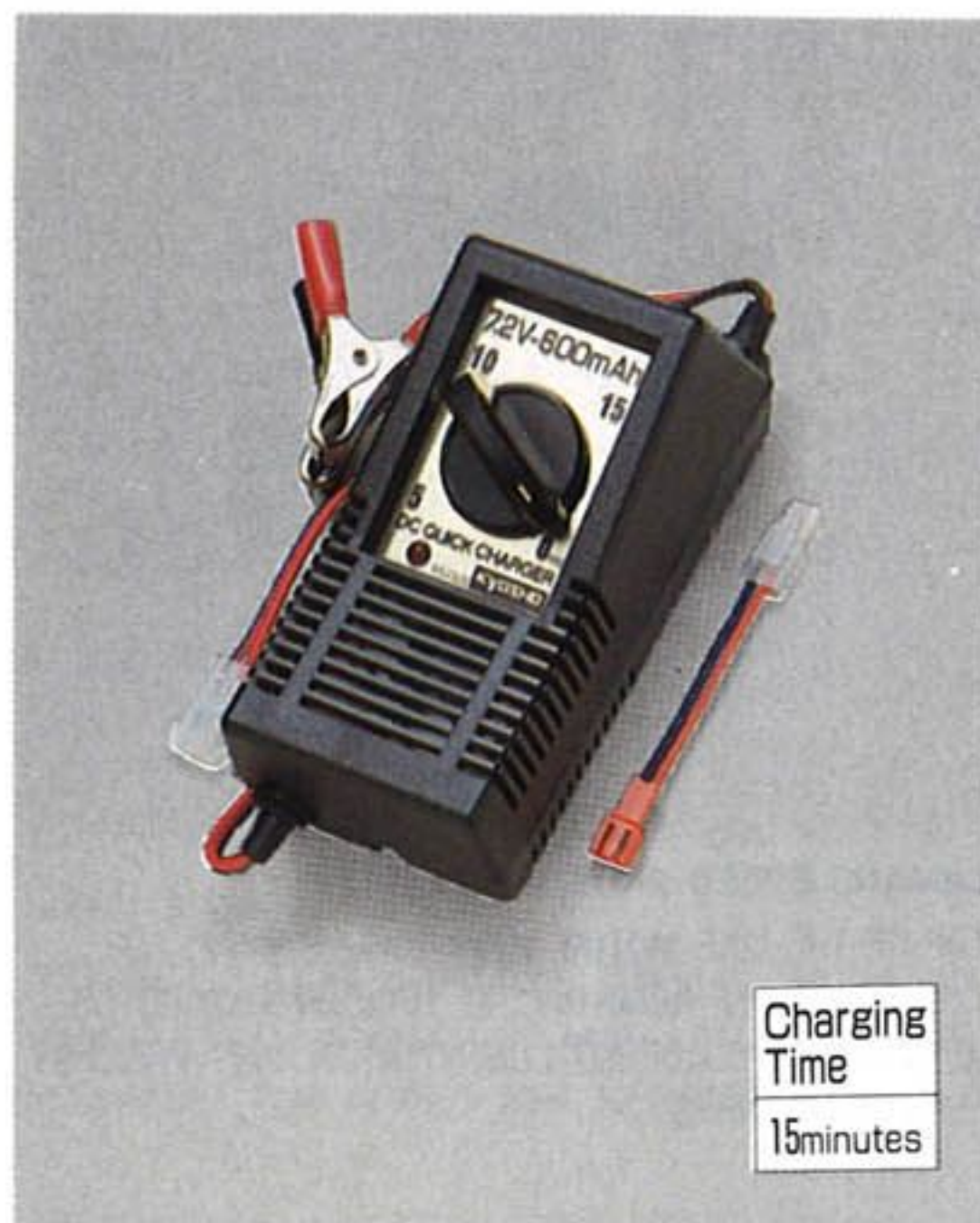

Charging
Time
15minutes

**DC QUICK CHARGER (7.2V-600mAh)
No.2325**

FOR 7.2V-600mAh ELECTRIC AIRPLANE/MOTORCYCLE NiCd PACKS. FACTORY PRE-SET CURRENT. AUTO SHUT-OFF. USES 12V CAR BATTERY.

Timerladdare avsedd för ack-paket på 7.2V/600mAh.

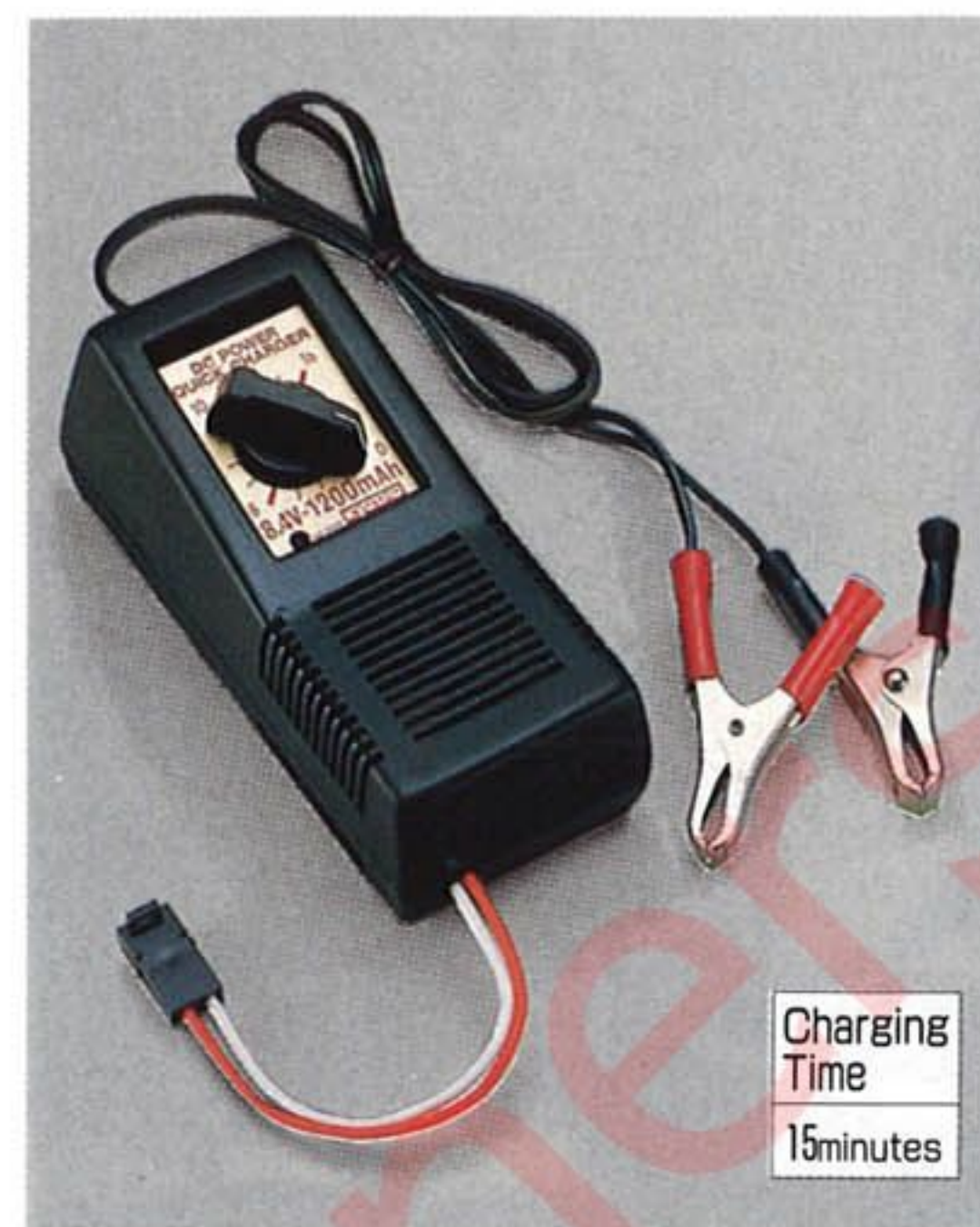

Charging
Time
15minutes

**DC POWER QUICK CHARGER (8.4V-1200mAh)
No.2327**

FACTORY PRE-SET CHARGING CURRENT. JUST SET THE REQUIRED CHARGING TIME (0 TO 15 MIN) AND CHARGER SWITCHES OFF AT END.

Timerladdare avsedd för ack-paket på 8.4V/1200mAh.

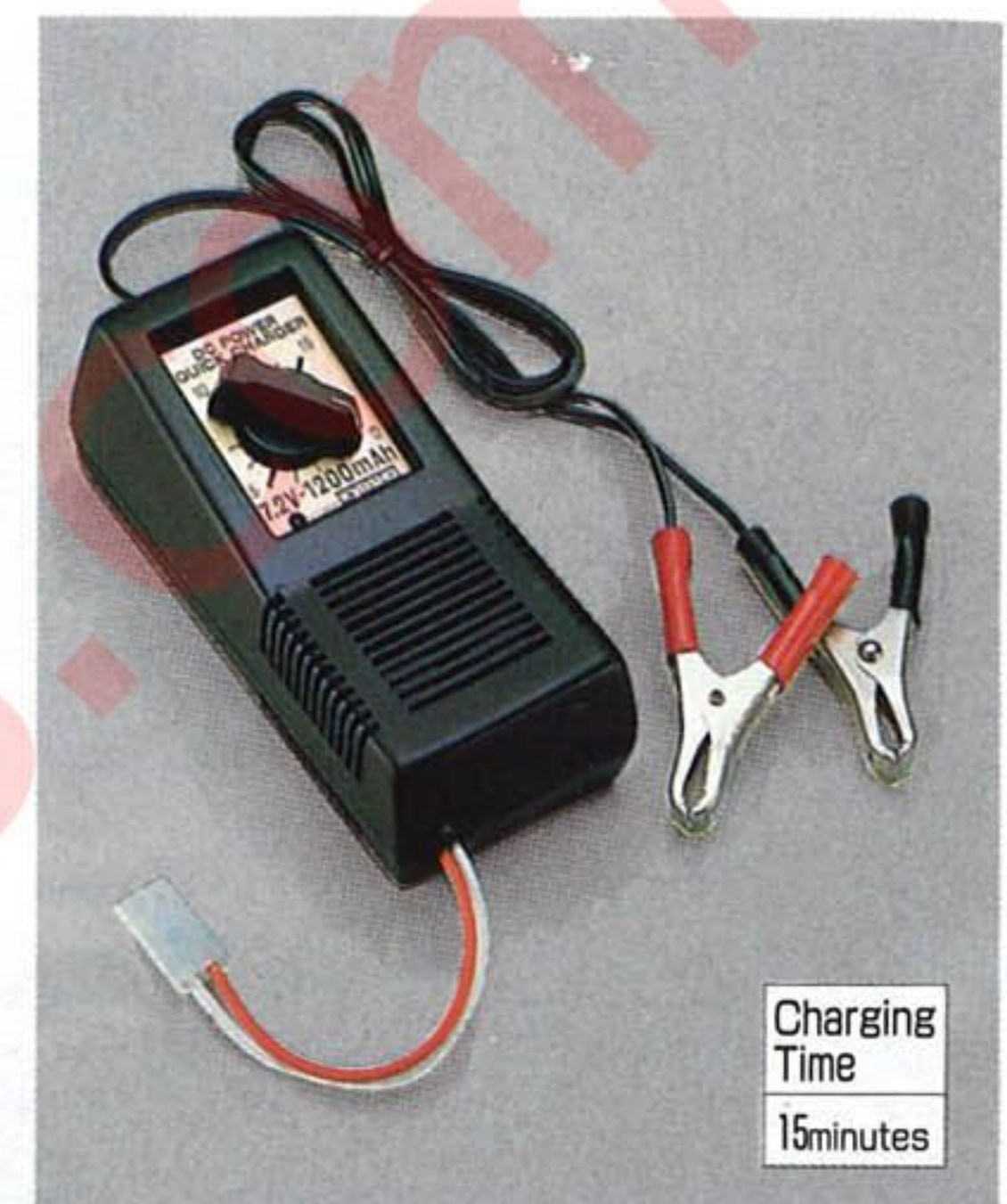

Charging
Time
15minutes

**DC POWER QUICK CHARGER (7.2V-1200mAh)
No.2326**

FOR FAST CHARGING ALL FAST-RECHARGEABLE 7.2V-1200mAh NiCd BATTERY PACKS, SUCH AS RACING OR POWER BATTERIES.

Timerladdare avsedd för ack-paket på 7.2V/1200mAh.



**DELTA PEAK CHARGER
No.1845**

100% CHARGE IN 20 MINUTES (LESS FOR PARTIALLY CHARGED BATTERIES). BATTERY CHARGED TO PEAK CAPACITY. FOR 100 TO 4000mAh 4.8 TO 8.4V NiCd PACKS. BUILT-IN AMMETER.

Den mest avancerade laddaren som själv "känner av" att ack-paketet blir fulladdat. För ack-paket på 4.8 - 8.4V.



**MULTI-CHARGER II
No.1849**

CHARGES ANY 4.8-8.4V/250-1800mAh NiCd BATTERY FOR TIME PERIOD. CAN ALSO DISCHARGE AT FIXED RATE. COMPARTMENT FOR LEADS.

Universalladdare som klara både urladdning och laddning av de flesta ackpaket. Elektronisk timer.

OBS: VAL AV STRÖMKÄLLA

Timerladdarna på den övre raden går alla att ansluta både till bilbatteri och bilbatteriladdare på 12V. När det gäller de mer avancerade laddarna på den nedre raden så måste dessa alltid anslutas till ett bil eller motorcykelbatteri. De får **aldrig** anslutas till en bilbatteriladdare.

RACING MOTORS

HIGH-PERFORMANCE MOTORS FOR ELECTRIC MODELS



ALL KYOSHO LeMANS AND SPA MOTORS ARE CUSTOM-DESIGNED FOR HIGH POWER OUTPUT AND RELIABLE SERVICE, REGARDLESS OF THE PRICE RANGE. FOUR STAFF MEMBERS WORK FULL-TIME DEVELOPING AND IMPROVING MOTOR DESIGNS, AND ALL MOTORS (AND PARTS USED IN THEM, EXCEPT BEARINGS) ARE PRODUCED IN KYOSHO'S OWN FACTORY IN LIMITED NUMBERS, SO THEY RECEIVE INDIVIDUAL ATTENTION (SEMI-HANDMADE).

TÄVLINGSELMOTORER I LE MANS & SPA SERIEN

Numera tillverkar Kyosho alla sina motorer i egen fabrik vilket garanterar högsta kvalitet och snabb framsynt utveckling för de olika områdena inom modellhobbyn. Det finns faktiskt nästan alltid en LeMans eller SPA motor som passar perfekt för ett visst användningsområde. I tabellen på nästa uppslag kan Du själv se vilka motorer som rekommenderas för olika modeller. Motorerna med "DM" nummer är avsedda för miniserien och de med "AP" nummer är speciella flygmotorer.



LeMANS 480T No.1892

FOR 8 MINUTE RACES. HIGH-TORQUE TYPE FOR MAXIMUM ACCELERATIONS IN 4WD VEHICLES WITH FORE-WHEEL INDEPENDENT SUSPENSION.



LeMANS 360 GOLD No.1925

THE TOP CHOICE FOR OFF-ROAD 1/10 SCALE BUGGY RACING AND POWER IN THE ROUGH. THE BEST CHOICE FOR REAR-MOTOR 2-WHEEL-DRIVE TYPES.



LeMANS SPEED 240T No.1986

TOP-OF-THE-LINE MOTOR (HIGH-TORQUE TYPE) FOR 1/10-SCALE OFF-ROAD RACING. HAND-WOUND ROTOR (0.7MM-16T). SOLDERED COMMUTATOR. WET PROCESS FERRITE MAGNETS.



LeMANS SPEED 480T No.1988

TOP-OF-THE-LINE MOTOR (HIGH-SPEED TYPE) FOR ON-ROAD RACING. HIGH EFFICIENCY FOR FULL-POWER 8-MINUTE RACES USING 1700mAh BATTERY. HAND-WOUND ROTOR (0.65MM-19T). SAME QUALITY FEATURES AS SPEED 240T.



LeMANS 480 GOLD No.1897

THE TOP CHOICE FOR 8-MINUTE RACING IN ROAD-RACING CARS AND 1/10 SCALE LIGHT-WEIGHT MID-ENGINE BUGGIES. HIGHEST TOP SPEED, EXCELLENT ACCELERATION.



LeMANS 480S No.1891

OPTIMIZED FOR LONG (UP TO 8 MINUTE) RACES IN LIGHTWEIGHT CARS (UNDER 900g) TO GIVE MAXIMUM TOP SPEED WITH GOOD ACCELERATION.

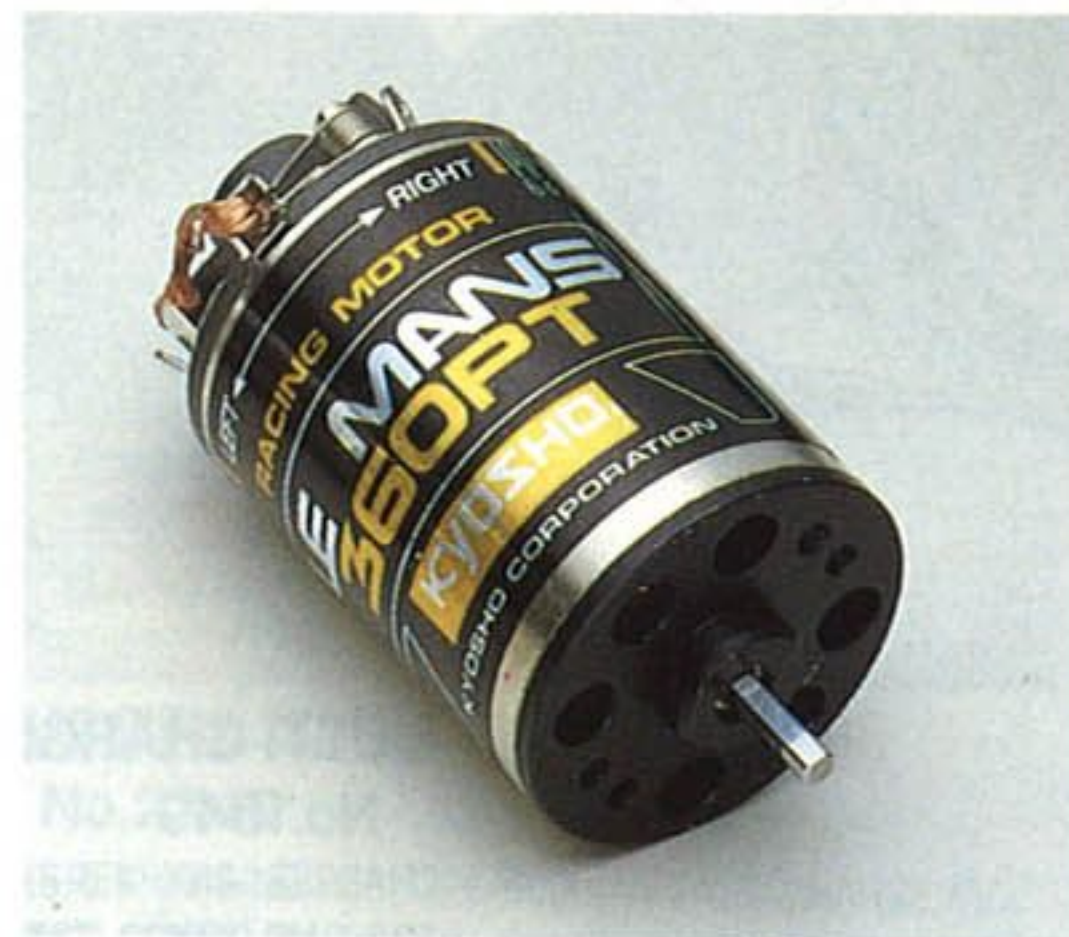

LeMANS 360PT No.1895

OPTIMIZED FOR OFF-ROAD RACING AND WHERE HIGH PERFORMANCE IN THE ROUGH IS NEEDED. LONGER ROTOR AND FIELD POLES FOR HIGHER TORQUE THAN 540 SIZE MOTORS.

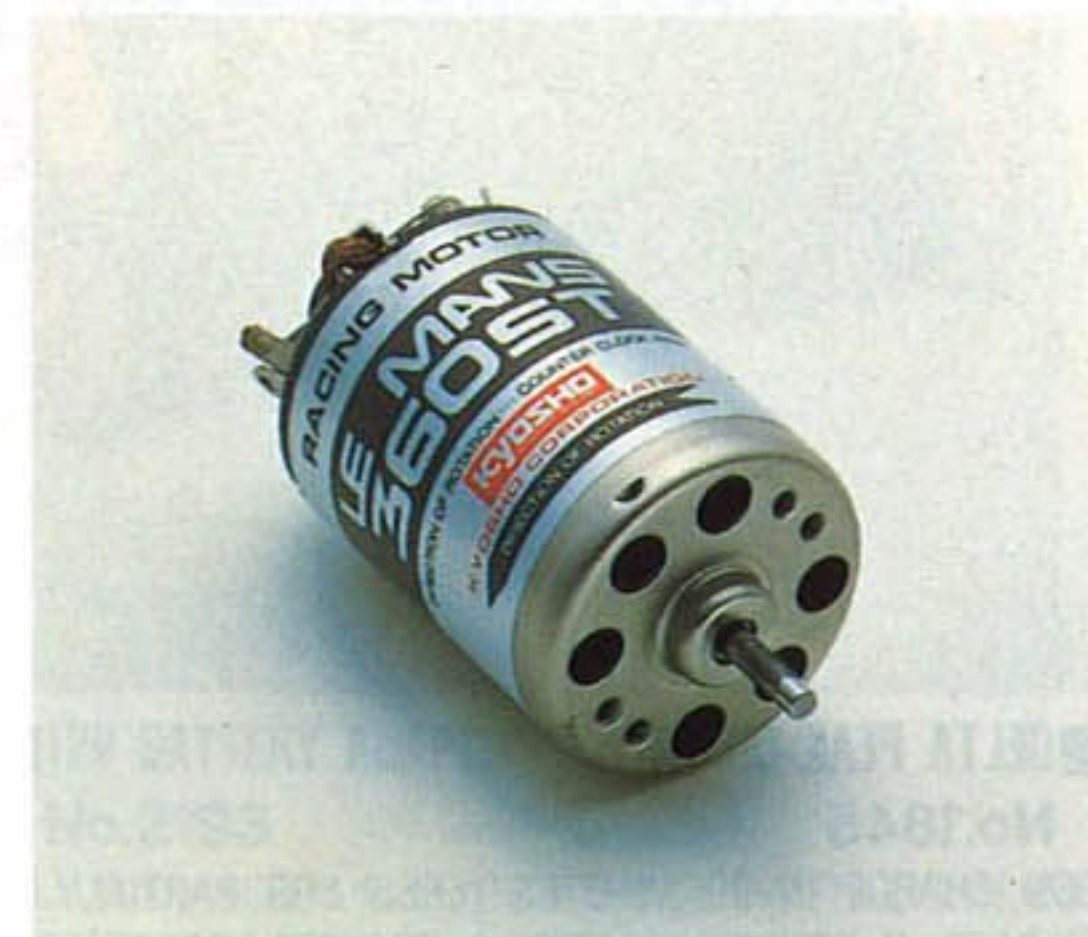

LeMANS 360ST No.1898

DESIGNED FOR OFF-ROAD BUGGIES WITH A LONGER ARMATURE AND FIELD POLES FOR HIGHER TORQUE. TIMING PRE-SET FOR MAXIMUM TORQUE.

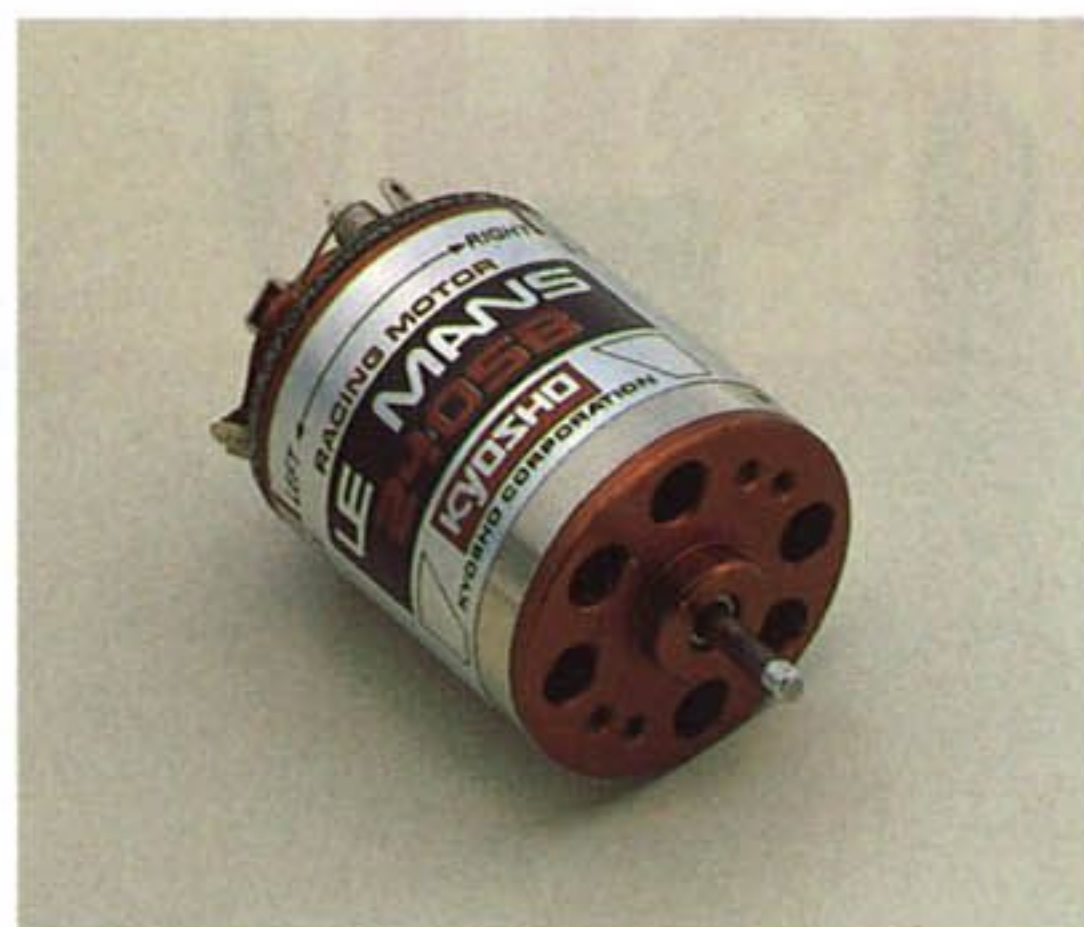

LeMANS 240SB No.1924

THE TOP CHOICE FOR 4-MINUTE SPRINT RACES IN 1/12 SCALE ROAD-RACING CARS WHERE ALL-OUT MAXIMUM SPEED AND ACCELERATION ARE REQUIRED.

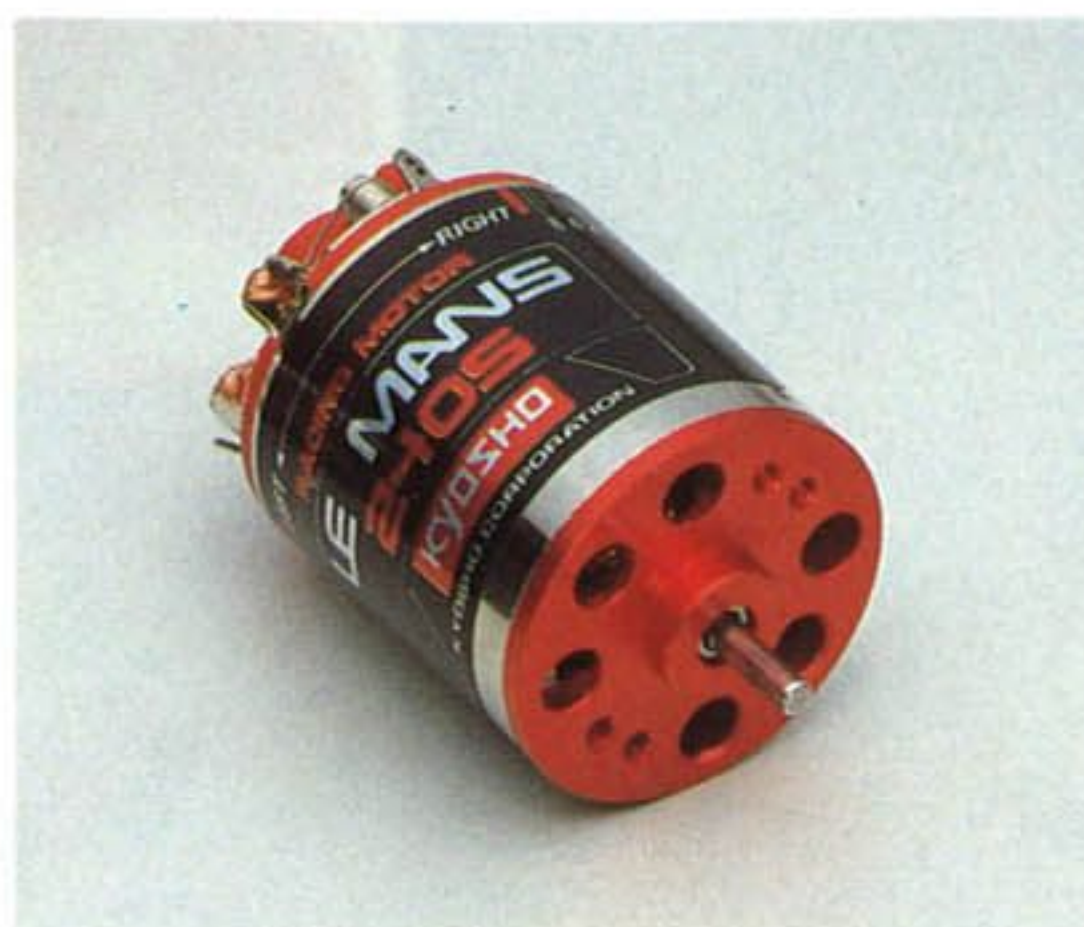

LeMANS 240S No.1893

OPTIMIZED FOR 4-MINUTE SPRINT RACES IN WHICH BOTH MAXIMUM ACCELERATION AND MAXIMUM TOP SPEED ARE NEEDED.



LeMANS 240ST No.1923

FOR 4 MINUTE RACES. DESIGNED FOR OFF-ROAD BUGGIES WITH A LONGER ARMATURE AND FIELD POLES FOR HIGHER TORQUE.



LeMANS 600E No.1894

AN EXCELLENT CHOICE FOR POWERING MODEL ROAD CARS. HIGH POWER, QUICK ACCELERATION, AND MODERATE BATTERY DRAIN.



LeMANS SPORTS H-240S No.1926

HIGH-PERFORMANCE FOR SPRINT RACES. DESIGNED FOR OFF-ROADERS AND ROAD RACERS WHERE MAXIMUM SPEED WITH GOOD ACCELERATION WINS THE RACE.



SPA-240WS No.W-1011

FOR 4-MINUTE SPRINT RACES WHERE THE HIGHEST POSSIBLE TOP SPEED AND ACCELERATION ARE REQUIRED.



SPA-480WT No.W-1012

FOR 8-MINUTE RACES. HIGH-TORQUE TYPE FOR MAXIMUM ACCELERATION AND IN 4WD MACHINES THAT CAN USE ALL AVAILABLE TORQUE.



LeMANS DM20 No.1934

SPECIAL HIGH-PERFORMANCE MINI MOTOR FOR BAJA-BUGS SERIES AND R/C MOTORCYCLES.



LeMANS DMC20BB No.1935

SPECIAL HIGH-PERFORMANCE MINI MOTOR. HIGH-SPEED TYPE FOR BAJA-BUGS SERIES AND R/C MOTORCYCLES.



LeMANS AP36 No.1962

CUSTOM DESIGNED FOR ELECTRIC MODEL AIRPLANES. VERY HIGH POWER OUTPUT. EXCELLENT IN KYOSHO PROP DRIVE UNITS.

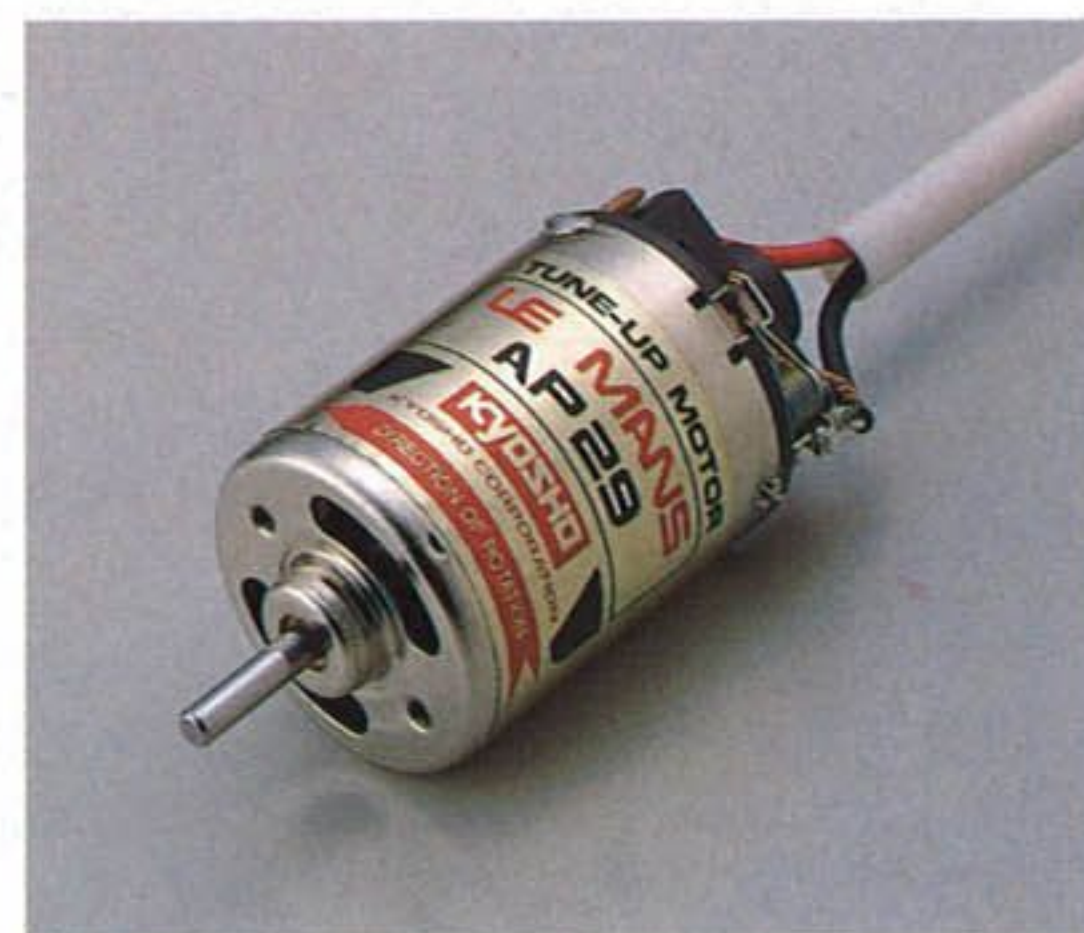

LeMANS AP29 No.1929

HIGH-TORQUE, WIDE USE TYPE, SUITABLE FOR MODEL AIRPLANES AND BOATS.



LeMANS AP29BB No.1930

SPECIAL HIGH-PERFORMANCE MOTOR FOR AIRCRAFTS AND BOATS.

MOTOR CHECKER No. 1896

ELECTRIC MOTOR ANALYZER

MOTOR BREAK-IN MACHINE

No. 1836

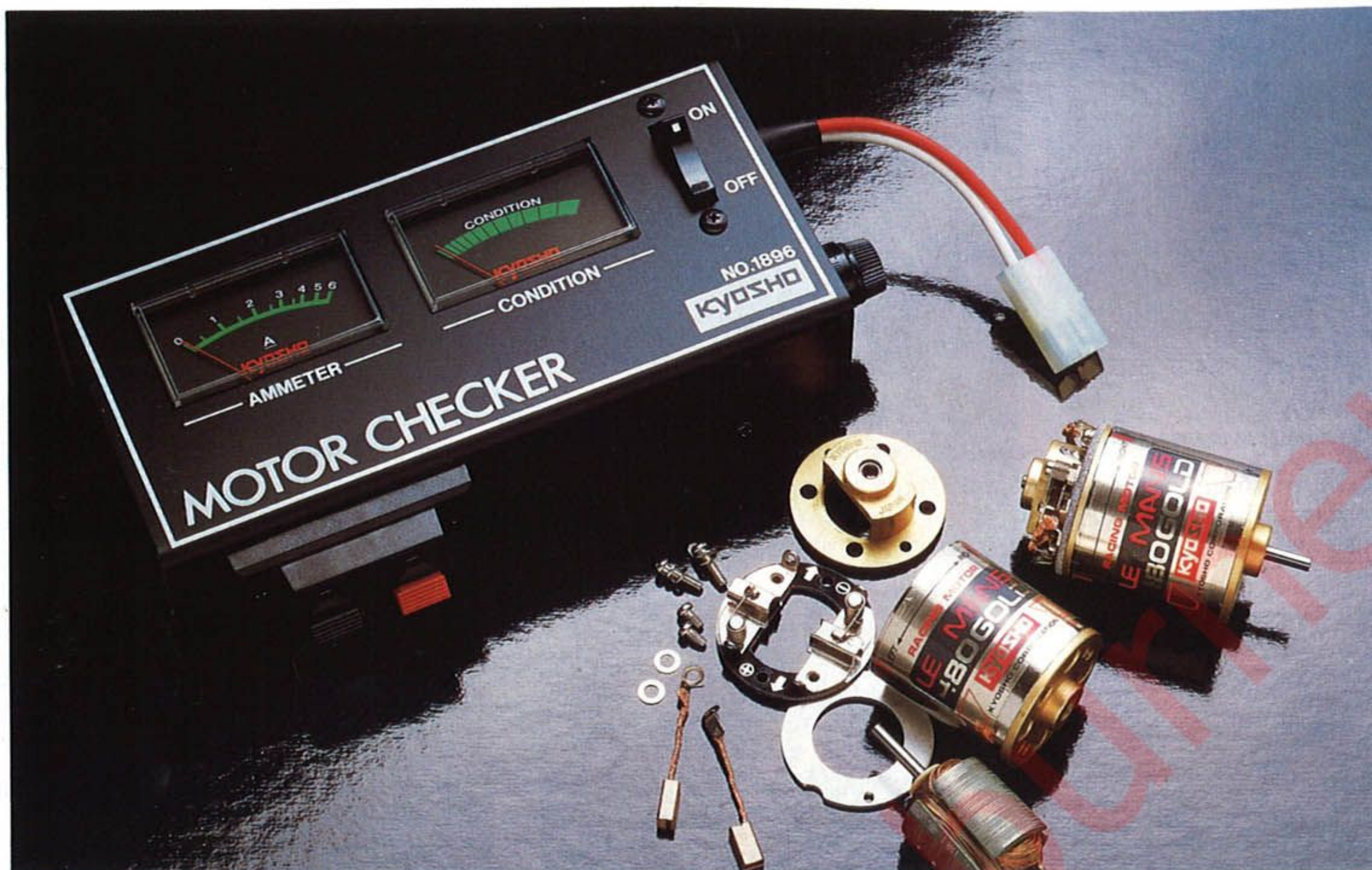

■ MOTOR BREAK-IN MACHINE No.1836 ● 4800

SUPPLIES LOW VOLTAGE FOR SLOW BREAK-IN RUNNING OF NEW MOTORS TO SHAPE BRUSH FACES. MAXIMIZES COMMUTATOR EFFICIENCY. USES 12V CAR BATTERY. WITH LEADS/AMMETER.

INKÖRNINGSAPPARAT FÖR ELMOTORER

Det låter kanske konstigt men det är mycket viktigt att låta en vass elmotor gå några timmar på låg spänning och utan belastning för att den skall fungera perfekt. Den här "maskinen" gör jobbet!

MOTOR CHECKER No.1896 ● 6800

DO YOU EVER WONDER IF THE MOTOR IN YOUR ELECTRIC COMPETITION CAR IS PERFORMING AT ITS BEST? THIS MOTOR ANALYZER A WORLD "FIRST" MAKES IT EASY TO CHECK BOTH THE TIMING ANGLE OF THE BRUSHES AND THE CONDITION OF THE BRUSHES AND COMMUTATOR.

MOTORTESTAPPARAT

Det här är en apparat som kräver massor av erfarenhet eftersom den till stor del bygger på att Du själv lär känna och kan "översätta" dess data till funktionen när motorn hamnar i bilen på banan. När Du väl lärt Dig är den ovärderlig hjälp när Du skall ställa in motorns förtändning och välja rätt motor för rätt tillfälle. Bara för proffs!

REKOMMENDATIONSTABELL FÖR LEMANS MOTORER

MOTOR	LeMans													SPA		
	NAME	480GOLD	480S	480T	360GOLD	360PT	360ST	240SB	240S	600E	SPORTS H-240S	SPEED 240T	SPEED 480T	AP36	240WS	480WT
BUGGIES	BIG BRUTE	○	○	○	○	○	○	△	△	○	△	△	△	△	△	○
	RAIDER 2WD	○	○	○	○	○	○	○	○	○	○	○	○	△	○	○
	MAXXUM FF	○	○	○	○	○	○	○	○	○	○	○	○	△	△	○
	ULTIMA PRO	○	○	○	○	○	○	○	○	○	○	○	○	△	△	○
	ULTIMA	○	○	○	○	○	○	○	○	○	○	○	○	△	△	○
	SHADOW 4WD	○	○	○	○	○	○	○	○	○	○	△	○	△	△	○
	ROCKY 4WD	○	○	○	○	○	○	○	○	○	○	○	○	△	○	○
	OPTIMA MID CUSTOM	○	○	○	○	○	○	○	○	○	○	○	○	△	○	○
	TURBO OPTIMA MID	○	○	○	○	○	○	○	○	○	○	○	○	△	○	○
TURBO ROCKY	○	○	○	○	○	○	○	○	○	○	○	○	△	○	○	
RACING CARS	HONDA CR-X	○	○	○	×	×	×	△	△	○	△	△	○	△	△	○
	PEUGEOT 205	○	○	○	×	×	×	△	△	○	△	△	○	△	△	○
	PLAZMA MKIII	○	○	○	×	×	×	△	△	○	△	△	○	△	△	○
	AXIS EX	○	○	○	×	×	×	△	△	○	△	△	○	△	△	○
AIRPLANES	FLASH EP	○	○	○	△	△	△	○	○	△	○	○	○	○	○	○
	VALENCIA 1800	○	○	○	×	×	×	○	○	△	○	○	○	○	○	○
	ETUDE 1200	○	○	○	○	○	○	○	○	△	○	○	○	○	○	○
	DUET 1200	○	○	○	○	○	○	○	○	△	○	○	○	○	○	○
	P-51D MUSTANG M36	○	○	○	△	△	△	○	○	△	○	○	○	○	○	○
ZERO FIGHTER M36	○	○	○	△	△	△	○	○	△	○	○	○	○	○	○	

MARKS: ○ = RECOMMENDED, ○ = SUITABLE, △ = NOT RECOMMENDED, × = WILL NOT FIT

**Option
House**

®

KYOSHO
THE FINEST RADIO CONTROL

SPECIAL PARTS

OPTION HOUSE

SPECIAL PARTS FOR RADIO CONTROLLED MODELS

No.W-0106



ADJUSTABLE ONE-WAY CLUTCH
(FOR OPTIMA MID SERIES)

No.W-0107



BALL DIFFERENTIAL
(FRONT) (FOR OPTIMA MID SERIES)

No.W-0108



BALL DIFFERENTIAL
(REAR) (FOR OPTIMA MID SERIES)

No.W-0109



BALL DIFFERENTIAL (FOR ULTIMA)

No.W-0110



SPECIAL COUNTER GEAR

No.W-0111



SPECIAL PINION

No.W-1001

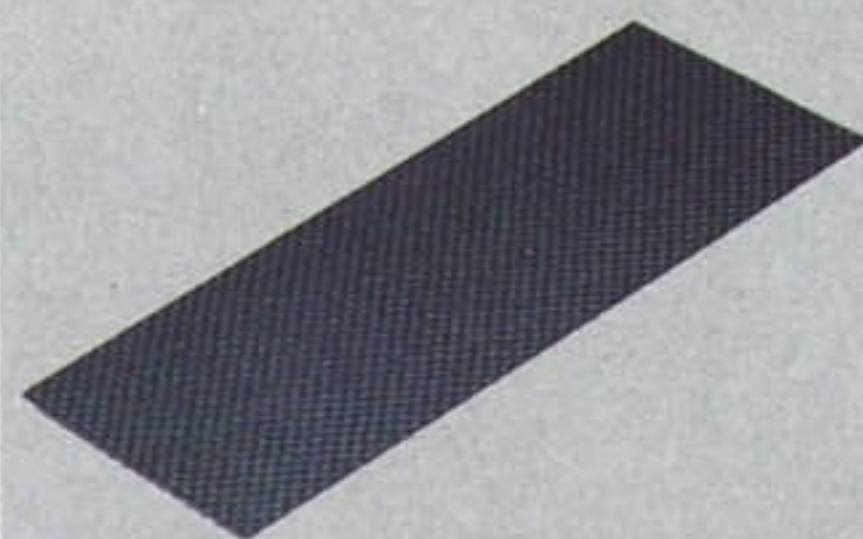

CARBON/EPOXY PLATE 1.7

No.W-1011

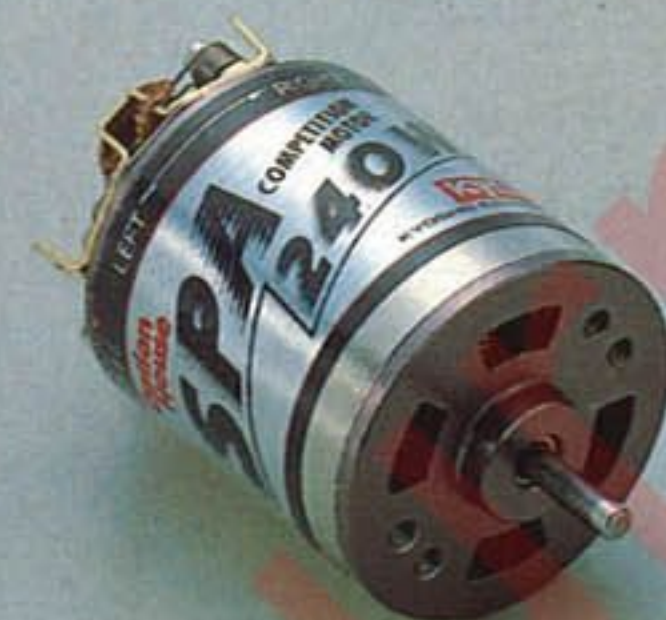

COMPETITION MOTOR, SPA-240WS

No.W-1012

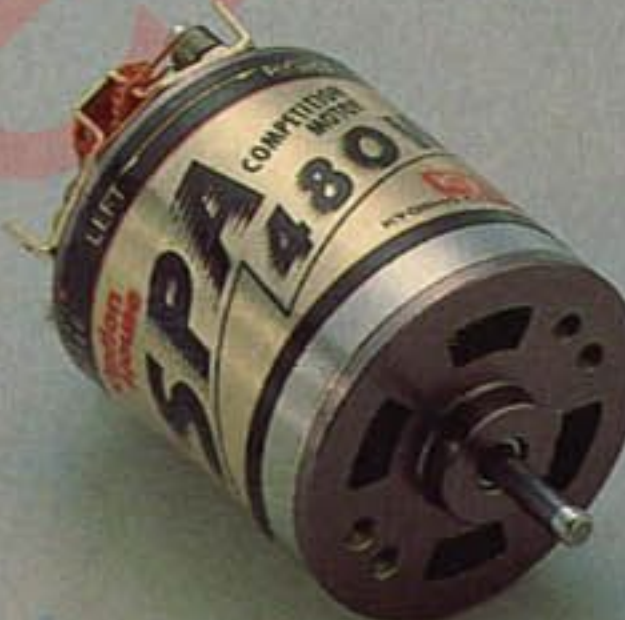

COMPETITION MOTOR, SPA-480WT

No.W-5001(S) No.W-5002(L)



PRESSURE OIL-FILLED SHOCK

No.W-5003(S)
No.W-5004(L)



ADJUSTABLE SHOCK (×2)

No.W-5005



QUICK ADJUST LINKAGE SET

No.W-5021



LARGE DIAMETER WHEEL

No.W-5022



NARROW WHEEL (CHROME PLATED)

No.W-5023



LARGE DIAMETER WHEEL (YELLOW)

No.W-5024



NARROW WHEEL (YELLOW)

No.W-5031



LOW PROFILE TIRE,
HIGH-GRIP TYPE

No.W-5032



LOW PROFILE TIRE,
GENERAL PURPOSE TYPE

No.W-5033



NARROW TIRE (PIN TYPE)

No.W-5034



NARROW TIRE
(FOR HARD SURFACES)



No.W-5042



TORQUE-LIMITING CLUTCH (12T)

No.W-5044(14T)
No.W-5046(16T)
No.W-5048(18T)

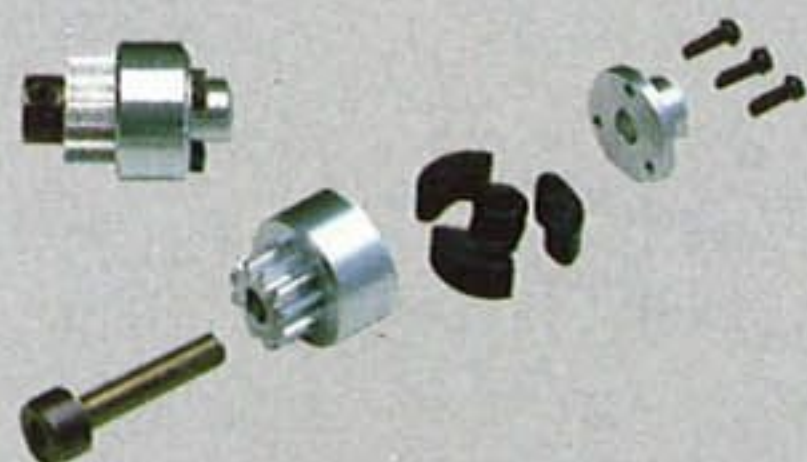

TORQUE-LIMITING CLUTCH

No.W-5061 No.W-5062



UNIVERSAL-JOINTED SWING SHAFT

No.W-5071



FRONT TIRE M-S
(BLOCK PATTERN : SOFT COMPOUND)

No.W-5072



FRONT TIRE M-H

No.W-5073



FRONT TIRE S-S
(PIN SPIKE : SOFT COMPOUND)

No.W-5074



FRONT TIRE S-H
(PIN SPIKE : HARD COMPOUND)

No.W-5075



NARROW TIRE SS-M
(LOW-HEIGHT, PIN SPIKE)

No.W-5076



NARROW TIRE MH-M
(MULTI PURPOSE SPIKE)

No.W-5077



LOW-PROFILE TIRE SS-M
(LOW HEIGHT PIN SPIKE)

No.W-5078



LOW-PROFILE TIRE MH-M
(MULTI PURPOSE SPIKE)

No.W-5085(15T) No.W-5090(20T)
No.W-5086(16T) No.W-5091(21T)
No.W-5087(17T) No.W-5092(22T)
No.W-5088(18T) No.W-5093(23T)
No.W-5089(19T) No.W-5094(24T)
No.W-5095(25T)



HARD PINION

SPECIAL PARTS

ELECTRIC POWERED RACING BUGGIES



No.OT-23 PINION (12T)
No.OT-24 PINION (15T)
No.OT-50 PINION (13T)



No.OT-38 SILICONE GREASE (2PCS)



No.OT-64 SPECIAL WING



No.OT-65 WING MOUNT SET



No.OT-66 LOW-PROFILE TIRE (PIN TYPE)



No.OT-67 WHEEL (LOW-PROFILE TIRE)



No.OT-76 HARD FINAL PINION



No.OT-90 WHEEL



No.OT-117 BODY (FOR TURBO OPTIMA MID SPECIAL)



No.OTW-1 ANTI-SWAY BAR SET (FOR OPTIMA MID)



No.OTW-2 SPECIAL SHOCK MOUNT (FOR OPTIMA MID)



No.OTW-3 SPECIAL CHASSIS (FOR OPTIMA MID)



No.UM-17 WHEEL SET (FRONT AND REAR × 2PCS EACH)



No.UM-23 PINION (18T)
No.UM-24 PINION (19T)
No.UM-25 PINION (20T)

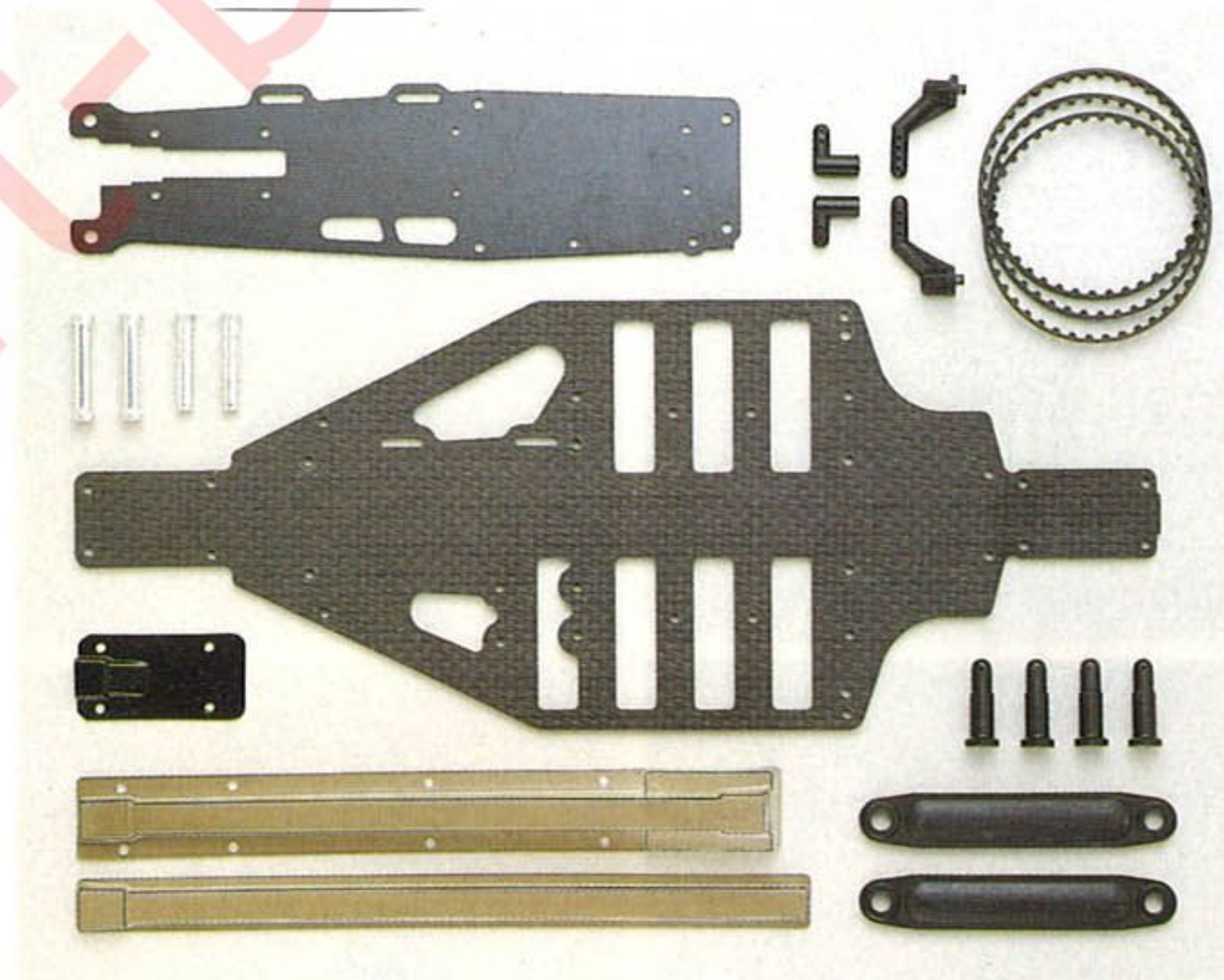

No.OTW-4 OPTIMA LONG WHEELBASE CONVERSION KIT

- ① No.OTW-5 MAIN CHASSIS
- ② No.OTW-6 UPPER PLATE
- ③ No.OTW-7 BELT (254T)
- ④ No.OTW-8 BELT COVER
- ⑤ No.OTW-9 BODY MOUNTING PARTS
- ⑥ No.OT-120 SERVO-SAVER SHAFT SET

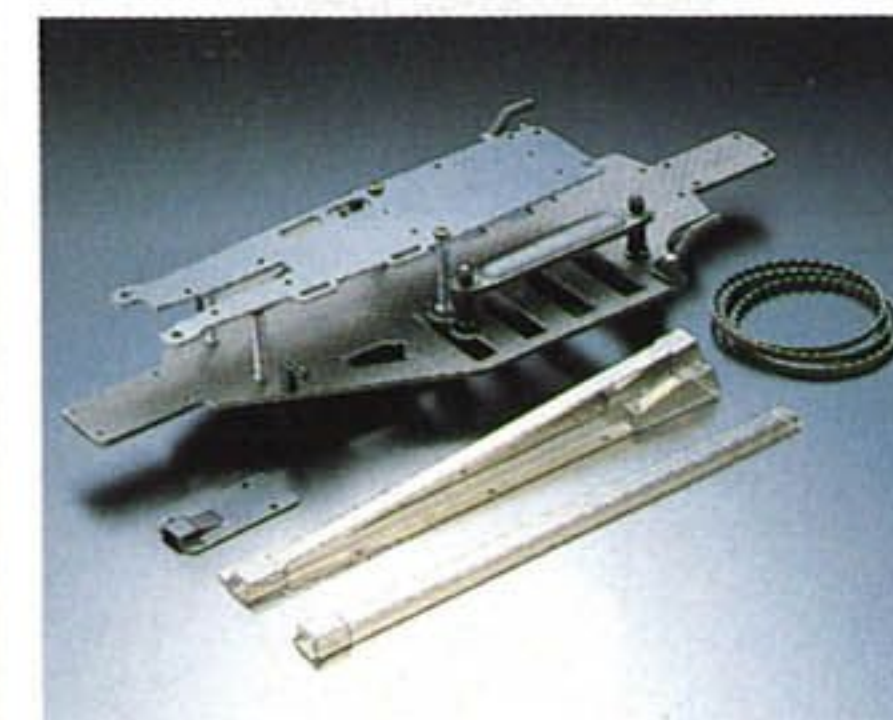

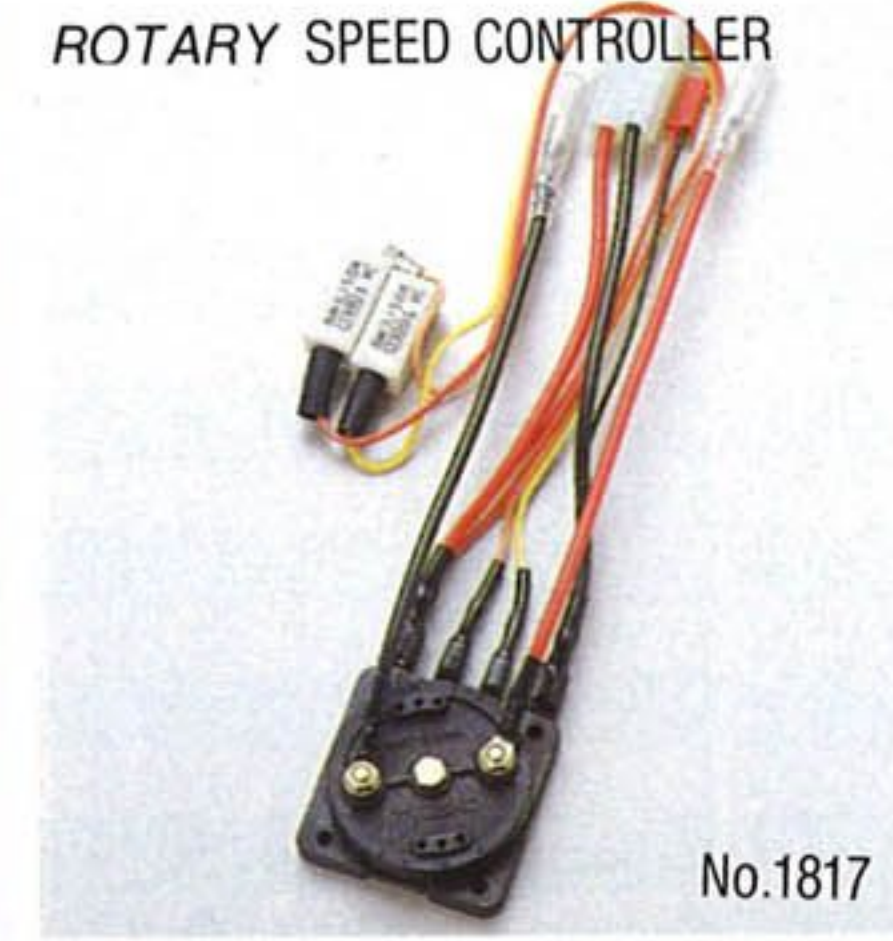
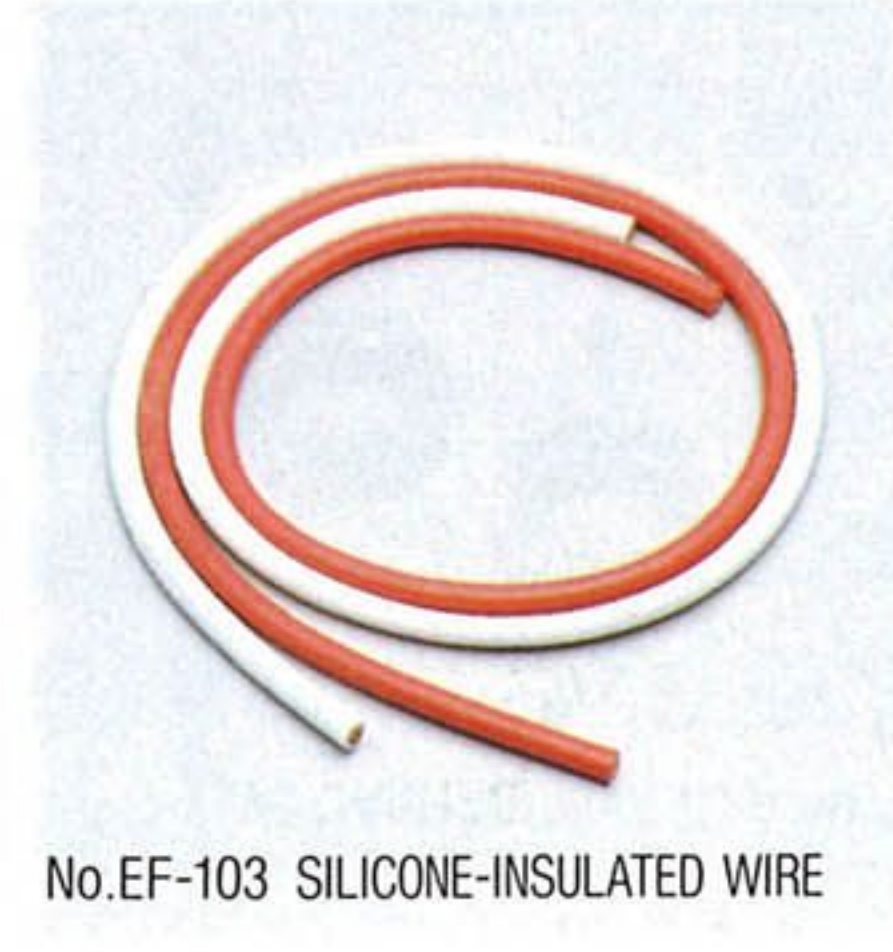

SPECIAL PARTS LIST

ELECTRIC POWERED RACING BUGGIES



No.1873 RUBBER TIRE A



No.1874 RUBBER TIRE B



No.1875 FRONT TIRE A
FRONTIER



No.1883 TEFLON HOBBY OIL,

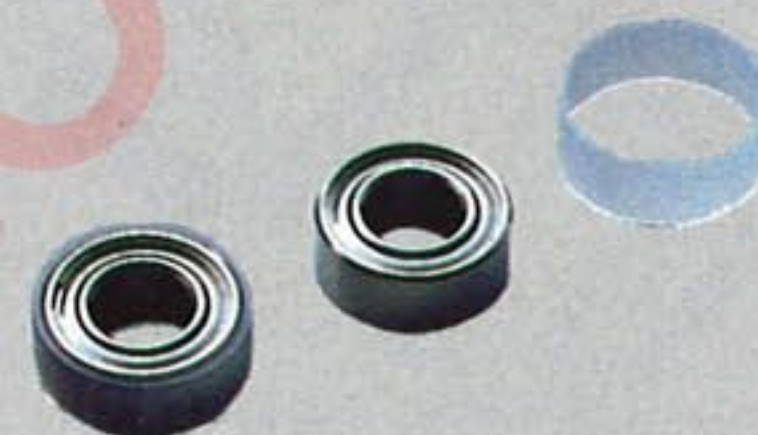

No.1901 BALL BEARING SET
($\phi 5 \times \phi 10$)



No.1902 BALL BEARING SET
($\phi 5 \times \phi 8$)



No.1903 BALL BEARING SET
($\phi 4 \times \phi 8$)



No.1911 BALL BEARING SET
($\phi 8 \times \phi 14$)



No.1945 OIL SPRAY



No.1951 SHOCK OIL SET



No.1952 DIFFERENTIAL OIL



No.1953 SILICONE OIL (S)
No.1954 SILICONE OIL (M)
No.1955 SILICONE OIL (H)



No.1972 BALL BEARING SET
(FOR ROCKY 4WD)



No.1974 BALL BEARING SET
(FOR ULTIMA)

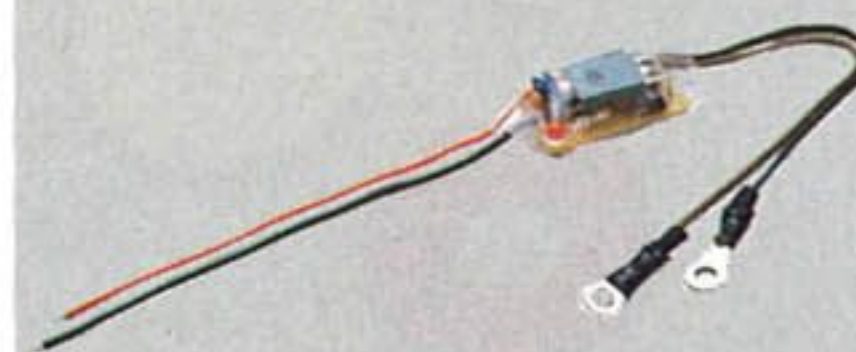

No.1990 REGULATOR (8.4V)

OPTION HOUSE

FOR ELECTRIC POWERED RACING BUGGIES



No.	NAME	AVAILABLE MODEL													
		MAXXUM FF	RAIDER 2WD	ULTIMA	ULTIMA PRO	TURBO ULTIMA	AERO STREAK 4WD	SHADOW 4WD	OPTIMA MID CUSTOM	OPTIMA MID	TURBO OPTIMA MID	TURBO OPTIMA MID SE	TURBO ROCKY	DOUBLE DARE 4WDS	HI-RIDER CORVETTE
W-0106	ADJUSTABLE ONE-WAY CLUTCH (FOR OPTIMA MID SERIES)							●	●	●	●				
W-0107	BALL DIFFERENTIAL (FRONT) (FOR OPTIMA MID SERIES)							●	●	●	○				
W-0108	BALL DIFFERENTIAL (REAR) (FOR OPTIMA MID SERIES)							●	●	●	○				
W-0109	BALL DIFFERENTIAL (FOR ULTIMA)	●		●	○	○									
W-0110	SPECIAL COUNTER GEAR	□		□	○	□									
W-0111	SPECIAL PINION	□		□	●	□									
W-1001	CARBON/EPOXY PLATE 1.7	▲		▲	▲	▲		▲	▲	▲	▲	▲			
W-5001	PRESSURE OIL-FILLED SHOCK (S)	●	●	UM-26	○	●	●	●	○	○	●	●			
W-5002	PRESSURE OIL-FILLED SHOCK (L)	●	●	UM-26	○	●	●	●	○	○	●	●	●	●	●
W-5003	ADJUSTABLE SHOCK (S) (×2)	●	●	UM-26	○	○	●	●	●	○	○	○			
W-5004	ADJUSTABLE SHOCK (L) (×2)	●	●	UM-26	○	○	●	●	●	○	○	○	●	●	●
W-5005	QUICK ADJUST LINKAGE SET	●		●	○	●		●	●	○	●	●			
W-5021	LARGE DIAMETER WHEEL	●	●	●	●	●	●	●	●	●	●	●	●		
W-5022	NARROW WHEEL (CHROME PLATED)	●					●	●	●	●	●	●			
W-5023	LARGE DIAMETER WHEEL (YELLOW)	●	●	●	●	●	●	●	●	●	●	●	●		
W-5024	NARROW WHEEL (YELLOW)	●					●	●	●	●	●	●			
W-5031	LOW PROFILE TIRE, HIGH-GRIP TYPE	●	■	●	●	●	●	●	●	●	●	●	●		
W-5032	LOW PROFILE TIRE GENERAL PURPOSE TYPE	●	■	●	●	○	●	●	●	●	●	●	●		
W-5033	NARROW TIRE (PIN TIPE)	△					△	△	○	△	△	△	△		
W-5034	NARROW TIRE (FOR HARD SURFACE)	△					△	△	●	△	△	△	△		
W-5042	TORQUE-LIMITING CLUTCH (12T)		●	●	●	●						●			
W-5044	TORQUE-LIMITING CLUTCH (14T)		●	●	●	●						●			
W-5046	TORQUE-LIMITING CLUTCH (16T)		●	●	●	●						●			
W-5048	TORQUE-LIMITING CLUTCH (18T)			●	●	●									
W-5061	UNIVERSAL-JOINTED SWING SHAFT	●		●	●	○		●	●	○	○				
W-5062	UNIVERSAL-JOINTED SWING SHAFT		●				●	●				●			
W-5071	FRONT TIRE M-S (BLOCK PATTERN: SOFT COMPOUND)		●	●	●	●									
W-5072	FRONT TIRE M-H (BLOCK PATTERN: HARD COMPOUND)		●	●	●	●									
W-5073	FRONT TIRE S-S (PIN SPIKE: SOFT COMPOUND)		●	●	●	●									
W-5074	FRONT TIRE S-H (PIN SPIKE: HARD COMPOUND)		●	●	○	●					△				
W-5075	NARROW TIRE SS-M (LOW-HEIGHT, PIN SPIKE)	△					△	△	●	△	△	△	△		
W-5076	NARROW TIRE MH-M (GENERAL PURPOSE SPIKE)	△					△	△	●	△	△	△	△		
W-5077	LOW-PROFILE TIRE SS-M (LOW-HEIGHT PIN SPIKE)	●	■	●	●	●	●	●	●	●	●	●	●		
W-5078	LOW-PROFILE TIRE MH-M (GENERAL PURPOSE SPIKE)	●	■	●	●	●	●	●	●	●	●	●	●		
W-5085	HARD PINION (15T)				●			●	●	●	●				
W-5086	HARD PINION (16T)				●			●	●	●	●				
W-5087	HARD PINION (17T)				●			●	●	●	●				
W-5088	HARD PINION (18T)				●			●	●	●	●				
W-5089	HARD PINION (19T)				●			●	●	●	●				
W-5090	HARD PINION (20T)				●			●	●	●	●				
W-5091	HARD PINION (21T)				●			●	●	●	●				
W-5092	HARD PINION (22T)				●			●	●	●	●				
W-5093	HARD PINION (23T)				●			●	●	●	●				
W-5094	HARD PINION (24T)				●			●	●	●	●				
W-5095	HARD PINION (25T)				●			●	●	●	●				

SPECIAL PARTS

FOR ELECTRIC POWERED RACING BUGGY

SPECIAL PARTS

No.	NAME	AVAILABLE MODEL														
		MAXXUM FF	RAIDER 2WD	ULTIMA	ULTIMA PRO	TURBO ULTIMA	AERO STREAK 4WD	SHADOW 4WD	OPTIMA MID CUSTOM	OPTIMA MID	TURBO OPTIMA MID	TURBO OPTIMA SE MID	TURBO ROCKY	DOUBLE DARE 4WDS	HI-RIDER CORVETTE	BIG BRUTE
OT-23	PINION (12T)															●
OT-24	PINION (15T)	○	●	○			●	●								●
OT-38	SILICONE GREASE (2 PCS)	●	●	●	●	●	●	●					●	●	●	●
OT-50	PINION (13T)						●	●					●			●
OT-51	PINION (14T)	●		●		●	●	●					●		●	●
OT-52	PINION (16T)	●		●		●	○	○					●			●
OT-53	PINION (17T)	●		●		●	●	●					●		●	●
OT-64	SPECIAL WING		●	●									●			
OT-65	WING MOUNT SET			●	○	○										
OT-66	LOW-PROFILE TIRE (PIN TYPE)	○	■	○	○	●	●	○	○	○	○	○	●			
OT-67	WHEEL (LOW-PROFILE TIRE)	●	●	●	●	●	●	●	●	●	●	●	●			
OT-76	HARD FINAL PINION	●		●	○	●										
OT-90	WHEEL	●	●	●	●	●	●	●	○	○	●	●				
OT-117	BODY (FOR TURBO OPTIMA MID SPECIAL)								○							
OT-120	SERVO-SAVER SHAFT SET								○	○	○	○				
OTW-1	ANTI-SWAY BAR SET (FOR OPTIMA MID)							●	●	○	○					
OTW-2	SPECIAL SHOCK MOUNT (FOR OPTIMA MID)							○	●	○	●					
OTW-3	SPECIAL CHASSIS (FOR OPTIMA MID)								●	○	○					
OTW-4	LONG WHEELBASE CONVERSION KIT							●	●	●	●					
OTW-5	MAIN CHASSIS							●								
OTW-6	UPPER PLATE							○								
OTW-7	BELT (254T)							○								
OTW-8	BELT COVER							○								
OTW-9	BODY MOUNTING PARTS (FOR OT-117)				○				○							
UM-17	WHEEL SET (FRONT AND REAR × 2PCS EACH)	●	●	○	●	●	●	●	●	●	●	●				
UM-23	PINION (18T)	●		●		●										
UM-24	PINION (19T)	●		●		●										
UM-25	PINION (20T)	●		●		●										
UM-26	SPECIAL SHOCK MOUNT			●	○	○										
UM-27	SPECIAL CHASSIS			●	○	○										
UM-28	MOTOR GUARD			●	○	●										
UM-29	ANTI-SWAY BAR SET			●	○	○										
UM-30	SPECIAL MECHANISM PLATE			●	○	○										
RK-2	WHEEL	●	●	●	●	●	●	●	●	●	●					
RK-15	LOW-PROFILE TIRE (SQUARE TYPE)	●	■	●	●	●	●	●	●	●	●					
RK-30	ANTI-SWAY BAR SET															
RK-31	ADJUSTABLE ONE-WAY CLUTCH											●				
EF-103	SILICONE-INSULATED WIRE	▲	▲	▲	▲	▲	▲	▲	▲	▲	▲	▲	▲	▲	▲	▲
LM-15	MOTOR COOLING PLATE	●	●	●	●	●	●	●	●	●	●	●	●	●	●	●
PI-15	BALL BEARING SET (φ8 × φ12)												●	●	●	●
1815	ROTARY SPEED CONTROLLER	○	●		●		○	▲	○			▲	○	○		●
1816	RESISTOR SET		▲					○				▲	●	●		▲
1817	ROTARY SPEED CONTROLLER			●		○			●	●	○					
1819	15W RESISTOR SET	○	▲		●		○		○				○	○		▲
1863	SPONSOR STICKERS	●	●	●	●	●	●	●	●	●	●	●	●	●	●	●

SPECIAL PARTS

No.	NAME	AVAILABLE MODEL														
		MAXXUM FF	RAIDER 2WD	ULTIMA	ULTIMA PRO	TURBO ULTIMA	AERO STREAK 4WD	SHADOW 4WD	OPTIMA MID CUSTOM	OPTIMA MID	TURBO OPTIMA MID	TURBO OPTIMA MID SE	TURBO ROCKY	DOUBLE DARE 4WDS	HI-RIDER CORVETTE	BIG BRUTE
1871	SPONGE TIRE A	●	●	●	●	●	●	●	●	●	●	●				
1872	SPONGE TIRE B, LOW-PROFILE		●													
1873	RUBBER TIRE A	○	●	○	○	○	○	○	○	○	○	○				
1874	RUBBER TIRE B	○	●	○	○	○	○	○	○	○	○	○				
1875	FRONT TIRE A		○	●	●	●										
1883	TEFLON HOBBY OIL, FRONTIER	●	●	●	●	●	●	●	●	●	●	●	●	●	●	●
1901	BALL BEARING SET (φ5 × φ10)	●	●	●	○	○	●	●	○	○	○	○	●	●	●	●
1902	BALL BEARING SET (φ5 × φ8)							●	○	○	○					
1903	BALL BEARING SET (φ4 × φ8)	●	●	●	○	○	●	●	○	○	○	●	●	●	●	●
1911	BALL BEARING SET (φ8 × φ14)	●		●	○	○	●	●	○	○	○					
1945	OIL SPRAY	●	●	●	●	●	●	●	●	●	●	●	●	●	●	●
1951	SHOCK OIL SET	●	●	●	●	●	●	●	●	●	●	●	●	●	●	●
1952	DIFFERENTIAL OIL	●		●	●	●	●	●	●	●	●	●	●	●	●	●
1953(S)	SILICONE OIL (S)	●	●	●	●	●	●	●	●	●	●	●	●			
1954(M)	SILICONE OIL (M)	●	●	●	●	●	●	●	●	●	●	●	●			
1955(H)	SILICONE OIL (H)	●	●	●	●	●	●	●	●	●	●	●	●			
1972	BALL BEARING SET (FOR ROCKY 4WD)											●				
1974	BALL BEARING SET (FOR ULTIMA)			●	○	○										
1990	REGULATOR (8.4V)											●				

LOW-VOLTAGE SOLDERING IRON HANDY IRON

No. 1825

No. 1826

HOT KNIFE SOLDERING IRON

No. 378



■ HANDY IRON No.1826

AN INVALUABLE TOOL WHEN COVERING WITH *EXCELCOTE*, *SILKYCOTE*, AND OTHER HEAT-ACTIVATED MATERIALS. SMALL SIZE FITS INTO TIGHT CORNERS AND GAPS. TWO NON-STICK (PTFE RESIN-COATED) TIPS, ONE FLAT, ONE ROUNDED. SELECTABLE HIGH AND LOW TEMPERATURE RANGES, (MAXIMUM 20W). FOR 100V. USE WITH TRANSFORMER (NOT INCLUDED) FOR OTHER VOLTAGES.

SÄLJS EJ I SVERIGE

12V LÖDKOLV

Det här är en utmärkt lödkolv som Du genom 12V driften alltid har tillgång till. Keramisk spets och mycket hög kvalitet.

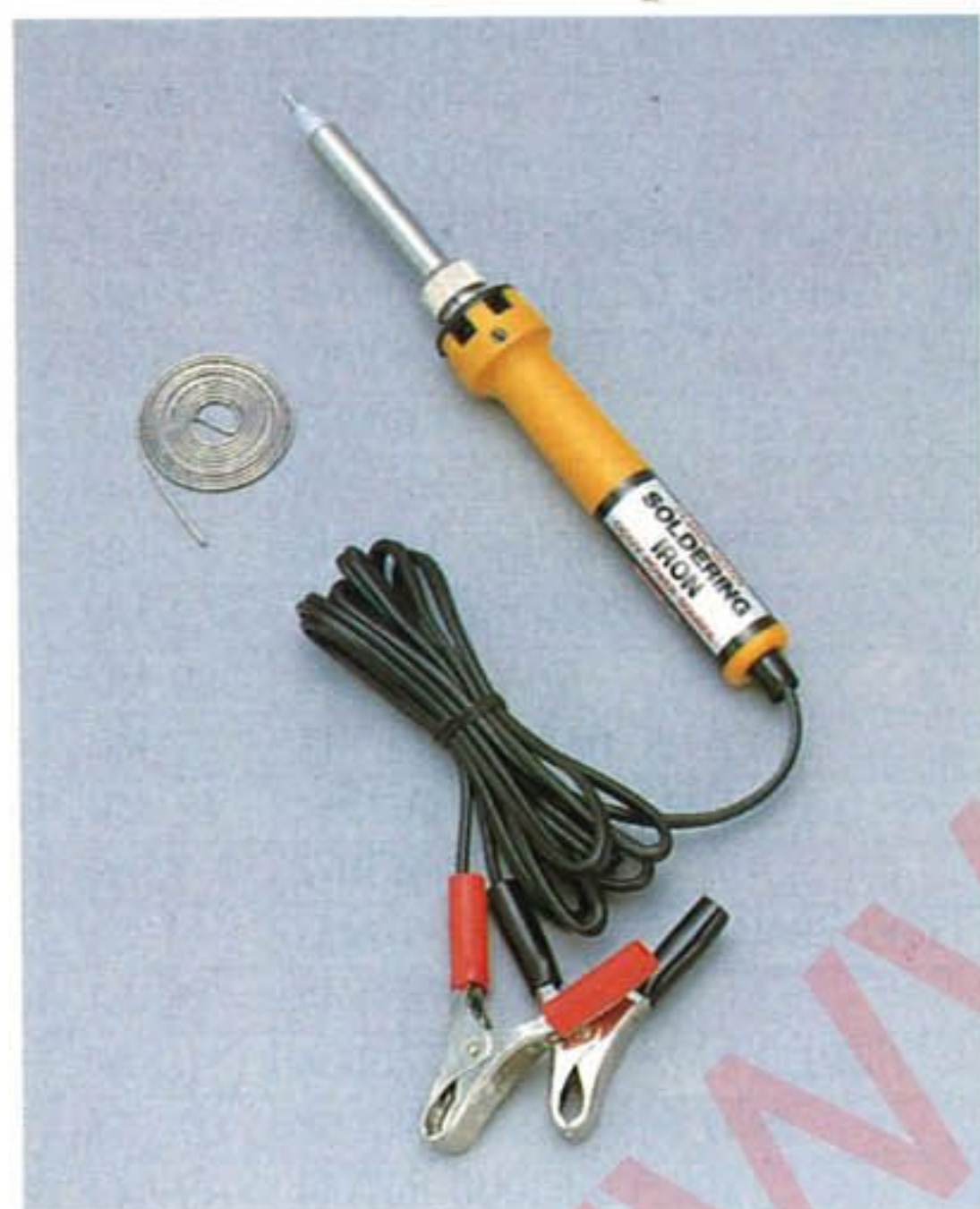

■ **LOW-VOLTAGE SOLDERING IRON** No.1825
OPERATES FROM 12V CAR BATTERY. CARRY TO FIELD IN TOOL KIT. FAST ONE-MINUTE WARM-UP DUE TO CERAMIC ELEMENT. 18W.

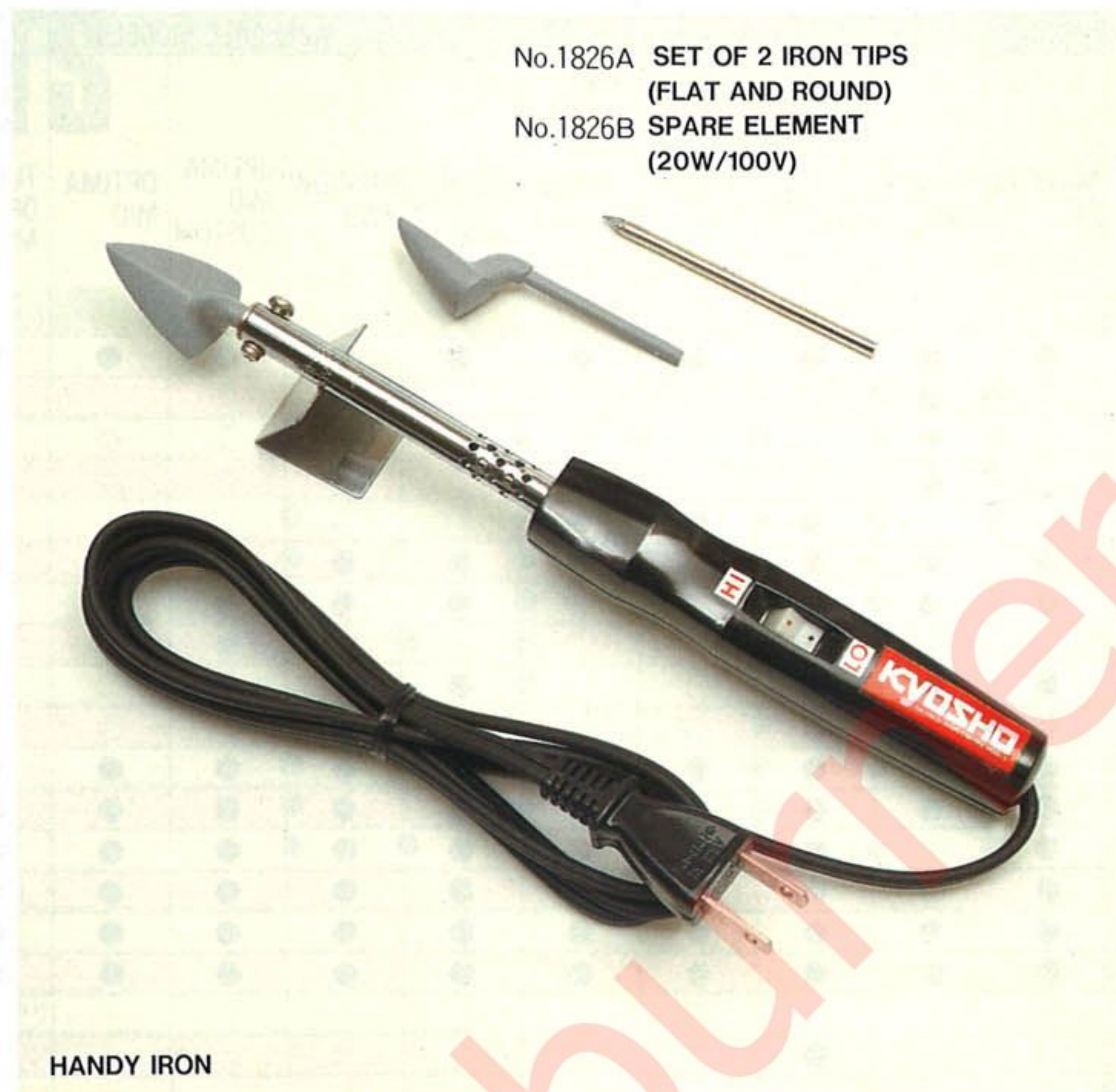

No.1826A SET OF 2 IRON TIPS
(FLAT AND ROUND)
No.1826B SPARE ELEMENT
(20W/100V)

HANDY IRON



No.378B SPARE BLADE, 12 EACH
No.378D SPARE CHUCK

HOT KNIFE SOLDERING IRON



■ **HOT KNIFE/SOLDERING IRON** No.378
COMBINATION OF SOLDERING IRON (30W) AND CUTTING BLADE ATTACHMENT THAT LETS IT CUT NEATLY THROUGH PLASTIC SHEET. INCLUDES SOLDER AND FLUX. FOR 100V. USE WITH TRANSFORMER (NOT INCLUDED) FOR OTHER VOLTAGES.

SÄLJS EJ I SVERIGE

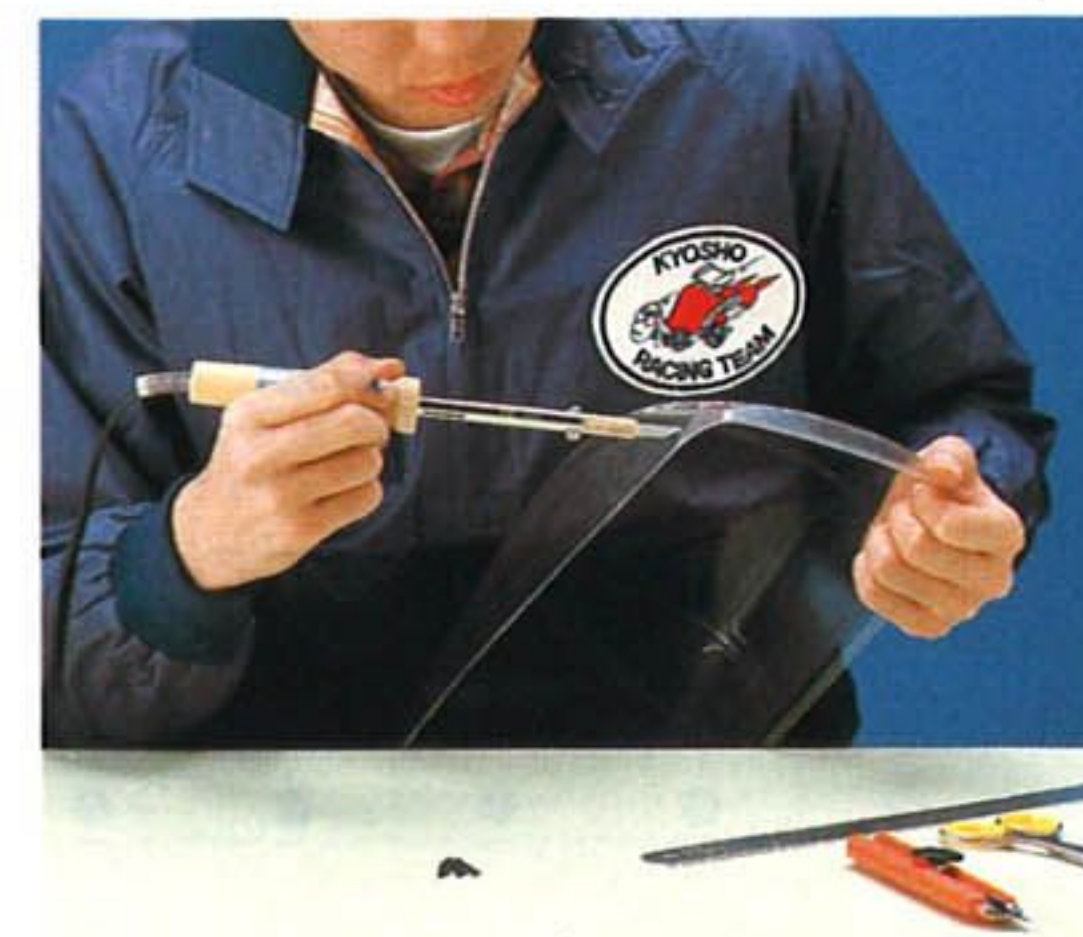

POLYCA COLOR

No. 2230

HOBBY SHEARS & SANDER

No. 1829

MICRON LINE TAPE

No. 1841 No. 1842 No. 1843



■ POLYCA COLOR No.2230

POLYCA ACRYLIC PAINT IS SPECIALLY FORMULATED FOR USE ON NEARLY ALL PLASTIC MATERIALS USED IN MODELS, SUCH AS POLYSTYRENE, POLYCARBONATE, ABS, BUTYRATE, ETC. FLEXIBLE. WATER-BASED.

POLYCA FÄRGER FÖR LEXAN

De här färgerna är vattenbaserade för att göra målningsjobbet så enkelt och ofarligt som möjligt. Ändå är de bränsletåliga när de väl härdat. Du målar alltid karossen från insidan och får på det viset en perfekt finish där den klara plasten i karossen fungerar som ett kraftigt klarlacksskikt. Tåligt för repor och enkelt att bättra på. Kan det bli enklare?



POLYCA COLOR

■ MICRON LINE (TRIPING TAPE No.1841/1842/1843

MICRON LINE TAPE GIVES THE LOOK THAT MARKS THE WORK OF A CRAFTSMAN, NEAT STRIPES OF EVEN WIDTH FROM ONE END TO THE OTHER. MICRON LINE CAN FOLLOW ALMOST ANY CURVE AND IS SELF-ADHESIVE, STICKING WITH JUST A TOUCH TO ANY SMOOTH SURFACE, SUCH AS PLASTIC CAR BODIES, SILKYCOTE, EXCELCOTE AND OTHER FINISHING MATERIALS, DOPED SURFACES, ETC. MICRON LINE TAPE COMES IN 6 COLORS AND 1, 1.5 AND 2.5mm WIDTHS (5m LENGTH).

MICROLINE FÖR DEKORERING

Med Micro-line tejen ger Du enkelt modellen det lilla sista för att den skall bli riktigt vacker och prydlig. Den finns i sex olika färger: vit, svart, blå, grön, gul och röd. Dessutom i tre olika bredder: 1, 1,5 och 2.5 mm. Alla lika lätta att forma genom den lätt kreppade ytan. För Dig som vill ge modellen det perfekta utseendet.



HOBBY SHEARS AND SANDER

■ HOBBY SHEARS AND SANDER No.1829

FOR CUTTING AND TRIMMING PLASTIC CAR BODIES, AND FOR USE AS UTILITY SHEARS FOR CUTTING THIN ALUMINUM AND OTHER SOFT METALS, PLASTIC SHEET, FIBERGLASS CLOTH, ETC. FLAT INNER SECTION OF BLADES MAKES STRAIGHT CUTS, WHILE CURVED TIPS MAKE TIGHT INSIDE CUTS FOR WHEEL-WELLS ETC.

SAX FÖR KAROSSER

Den här saxen är det perfekta hjälpmedlet för att på bästa sätt klippa ren karossen till Din modell. De lätt krökta skären gör det enkelt att följa alla former Du önskar. Levereras med praktisk sandpappersfil som Du använder för att slutgiltigt jämna till alla kanter med.

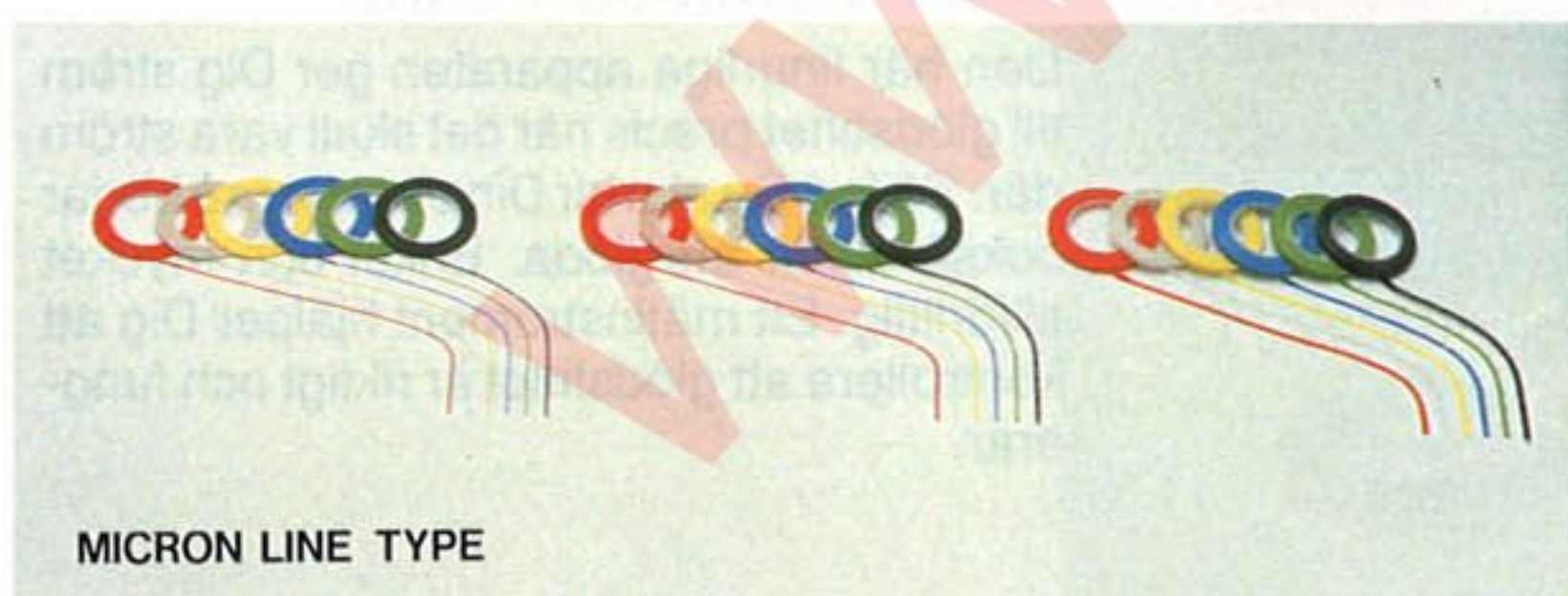

MICRON LINE TYPE

BLITZ STARTER

No. 1791

POWER DIVIDER

12 VOLT D.C. DIVIDER TO 1.5 VOLT AND 12 VOLT. No. 1835

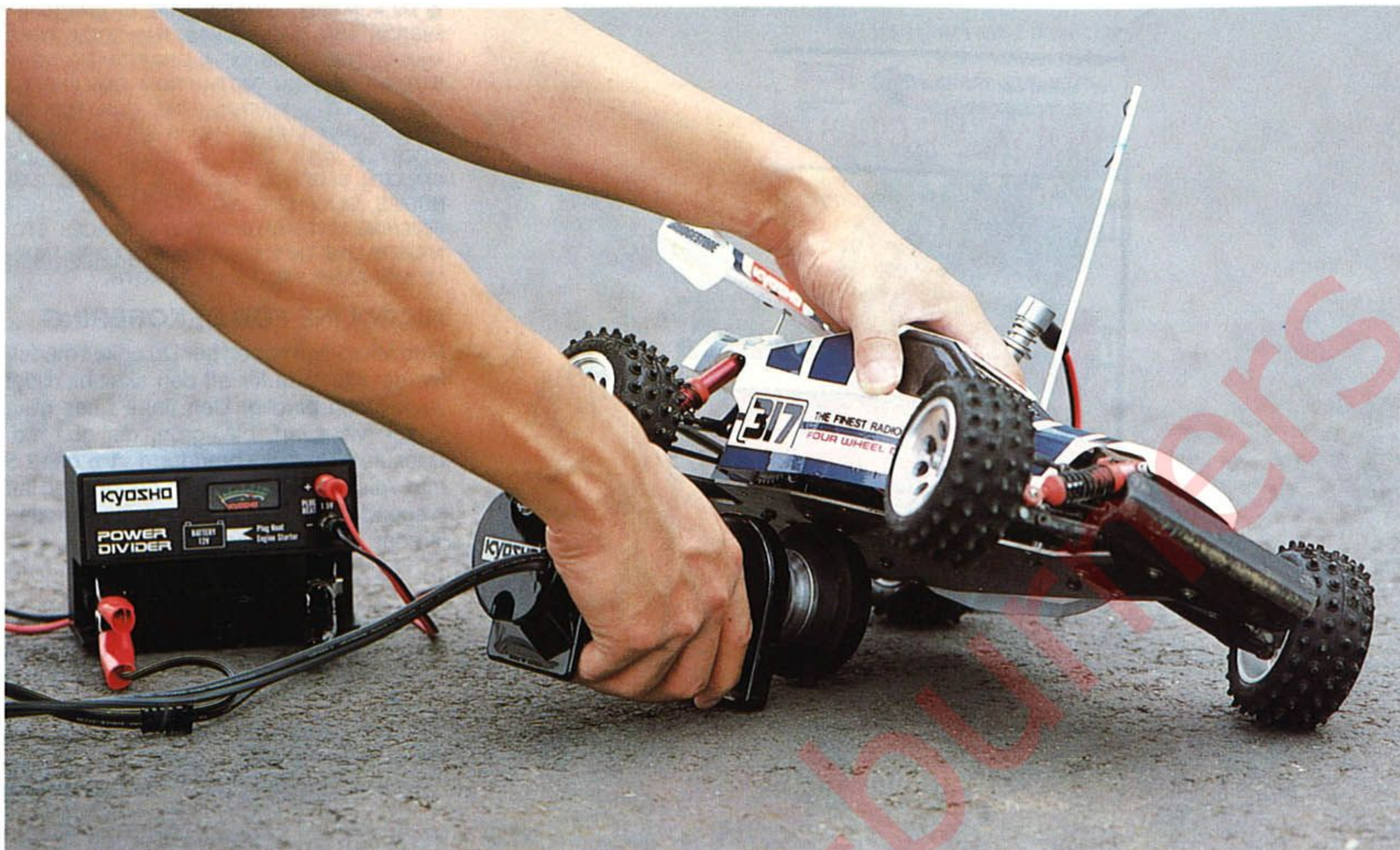

BLITZ STARTER



POWER DIVIDER

■ BLITZ STARTER No.1791

- DIRECT-DRIVE, HIGH-SPEED, HIGH-TORQUE TYPE.
- STARTS 2-STROKE ENGINES UP TO. 61, 4-STROKE UP TO. 91 SIZE.
- STARTS SMALL 2-STROKE ENGINES THAT REQUIRE HIGH CRANKING SPEED.
- STARTS AIRCRAFT ENGINES WITH OR WITHOUT SPINNER.
- STARTS CAR ENGINES BY RUBBER DRIVE WHEEL (OPTION #BZ-1).
- STARTS HELICOPTERS/BOATS USING BELT BY GROOVED PULLEY (BELT NOT INCLUDED).
- SQUEEZE-TYPE SWITCH FOR CONVENIENT ONE-HAND OPERATION.
- COLOR-CODED BATTERY CLIPS FITTED.
- OPERATES FROM 12V BATTERY (5Ah OR HIGHER).

ELEKTRISK STARTAPPARAT

Det här är en mycket kraftig elektrisk motor som Du kopplar till ett bilbatteri på 12V och med vars hjälp Du sedan startar både Dina bilar, båtar, flygplan och helikoptrar. Alla modeller där Du använder förbränningsmotorer. Mycket robust utförande ger lång livslängd och snabba starter.

■ POWER DIVIDER No.1835

CONVENIENT FOR STARTING GLOW ENGINES. CONNECT TO 12V CAR BATTERY. ONE SET OF CONNECTIONS FOR POWERING ELECTRIC STARTER, ONE SET FOR HEATING 1.5V GLOW PLUGS. BUILT-IN AMMETER INDICATES CONDITION OF GLOW PLUG AND CURRENT DRAWN.

GLÖDSTRÖMSDRIVARE

Den här finurliga apparaten ger Dig ström till glödstiftet precis när det skall vara ström där. Så fort Du startar Din elstarter så börjar också stiftet att glöda. Enkel och mycket tillförlitlig. Ett mätinstrument hjälper Dig att kontrollera att glödstiftet är riktigt och fungerar.

K&B STARTER PACK

STARTING SET FOR MODEL GLOW-PLUG ENGINES

No. 6401

K&B HANDY FUEL

FUEL FOR MODEL GLOW-PLUG SÄLJS EJ I SVERIGE

No. 6411

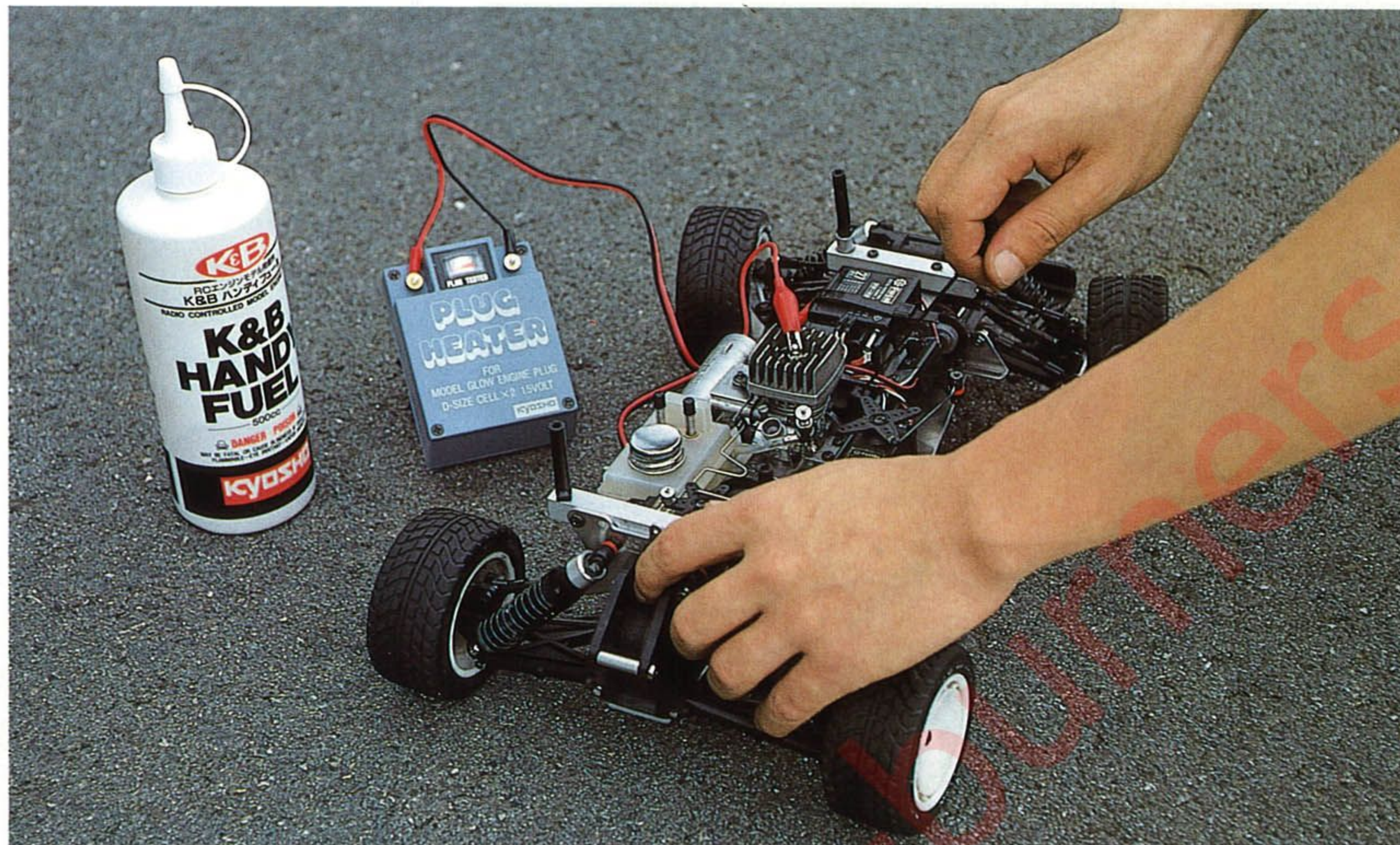

SÄLJS EJ I SVERIGE

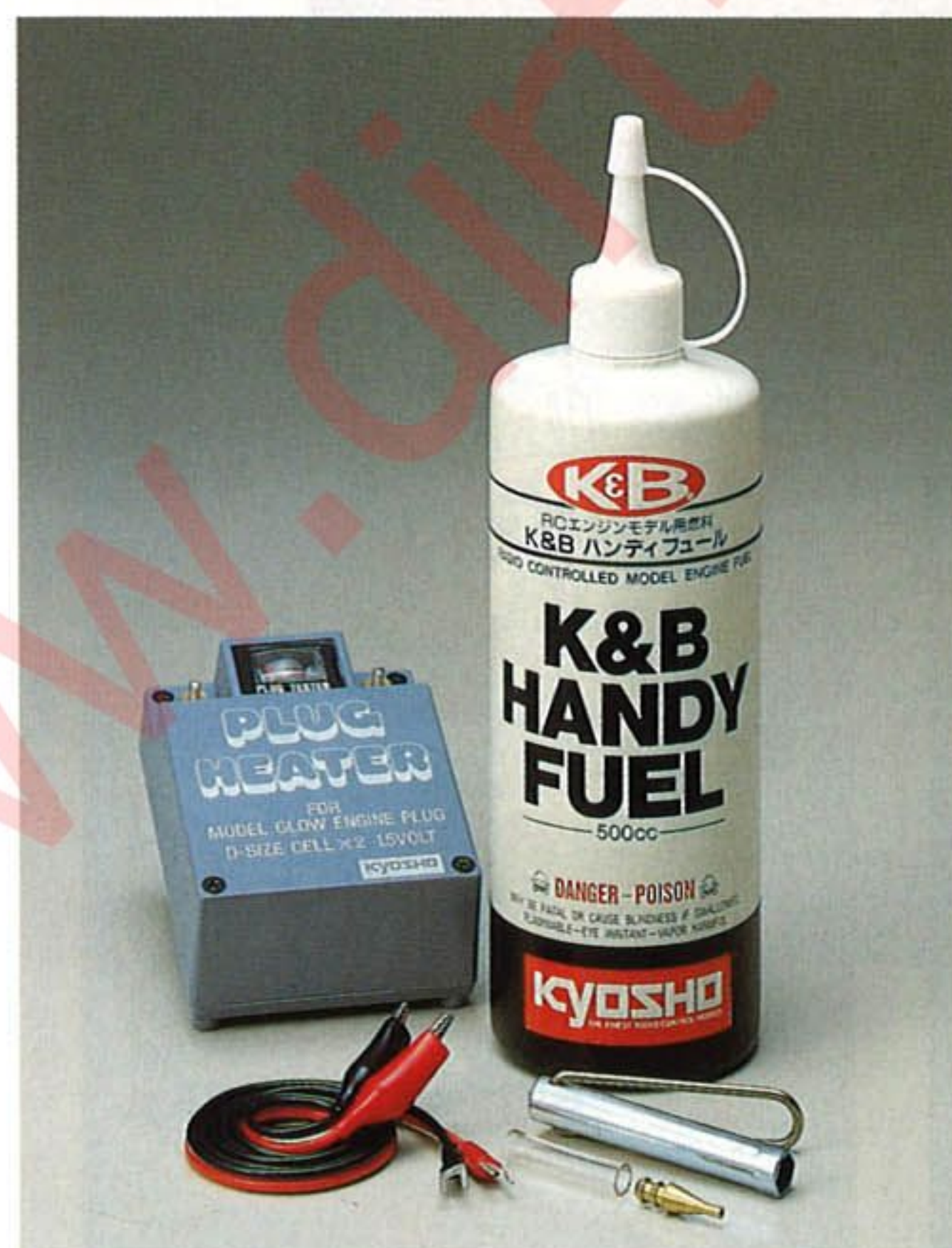

K&B FUELS, GLOW PLUGS & KYOSHO RACING FUELS



SÄLJS EJ I SVERIGE



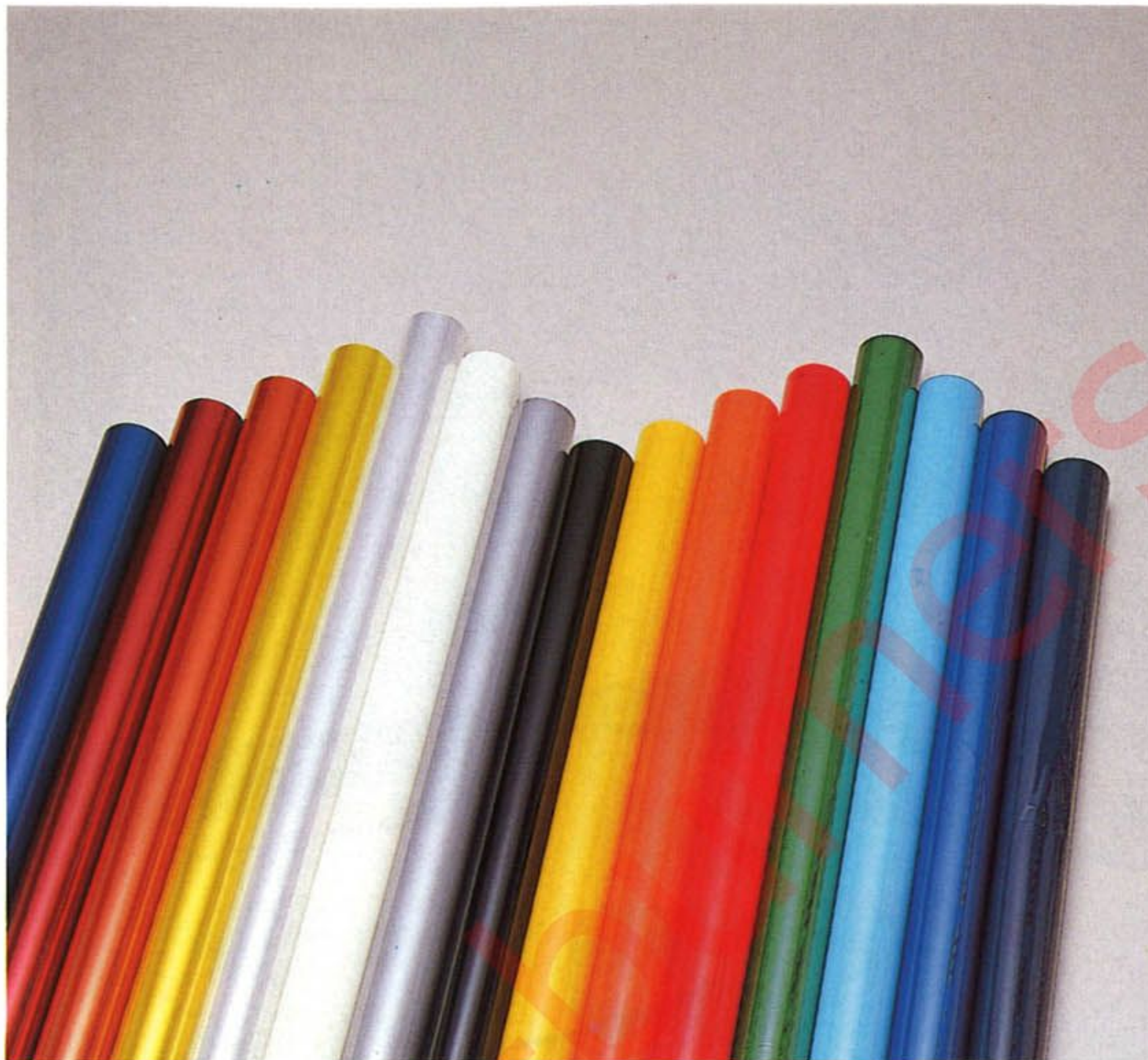

■ EXCELCOTE
GIVE YOUR FAVORITE AIRPLANE A PERFECT FINISH.

A STRONG, HIGH-QUALITY POLYESTER FILM MATERIAL FOR COVERING MODEL AIRCRAFT. STRENGTHENS THE STRUCTURE, AND GIVES A BEAUTIFUL GLOSSY FINISH THAT WOULD BE DIFFICULT TO MATCH WITH CONVENTIONAL FINISHES. SCRATCH RESISTANT AND WATERPROOF. JUST APPLY WITH A HOT IRON, TACKING IT INTO POSITION AT INTERVALS, THEN ADHERING IT TO THE ENTIRE STRUCTURE. LOCAL HEATING SHRINKS IT TO FIT CURVED SURFACES AND TAKE OUT SLACK OR WRINKLES. FUELPROOF. AVAILABLE IN 15 COLORS, SOLID, METALLIC, AND TRANSPARENT.

EXCELCOTE BEKLÄDNADSFILM

Det här är en av de allra bästa filmerna för beklädnad som finns på marknaden. Fungerar väl även på svåra ytor som dubbelkrökta hörn etc. Finns i hela tolv olika färger och levereras i rullar med en bredd på 650 mm och med en längd på 1800 mm per rulle. Färgerna ser Du på bilden till vänster och i tabellen nedan.

1688-W	WHITE
-O	ORANGE
-Y	YELLOW
-R	RED
-G	GREEN
-SB	SKY BLUE
-RB	ROYAL BLUE
-TR	TRANS. RED
-TY	TRANS. YELLOW
-TO	TRANS. ORANGE
-MB	METALLIC BLUE
-TB	TRANS. BLUE
-BK	BLACK
-S	SILVER
-C	CLEAR

● SIZE : W 650 × L 1,800mm



SÄLJS EJ I SVERIGE

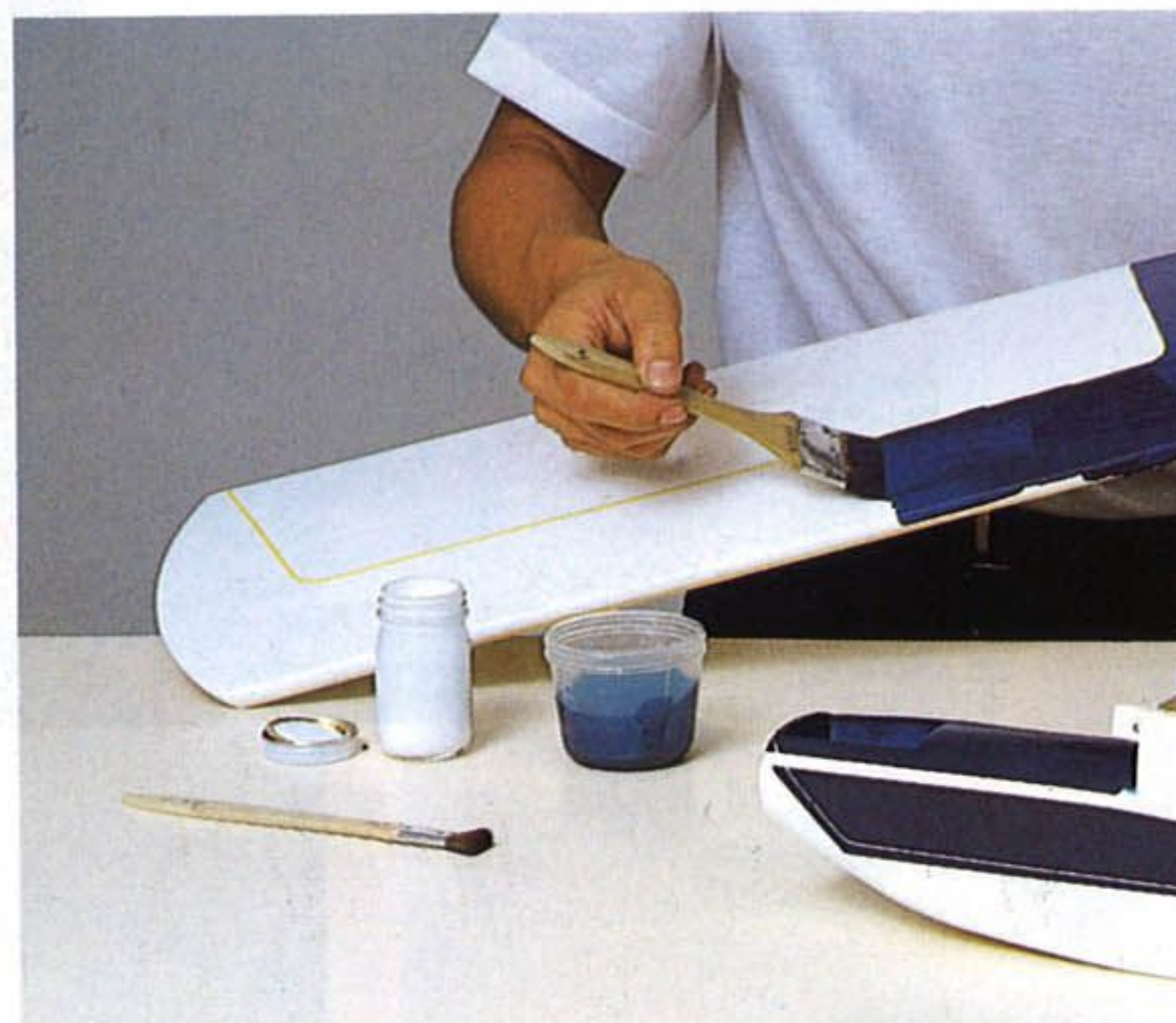
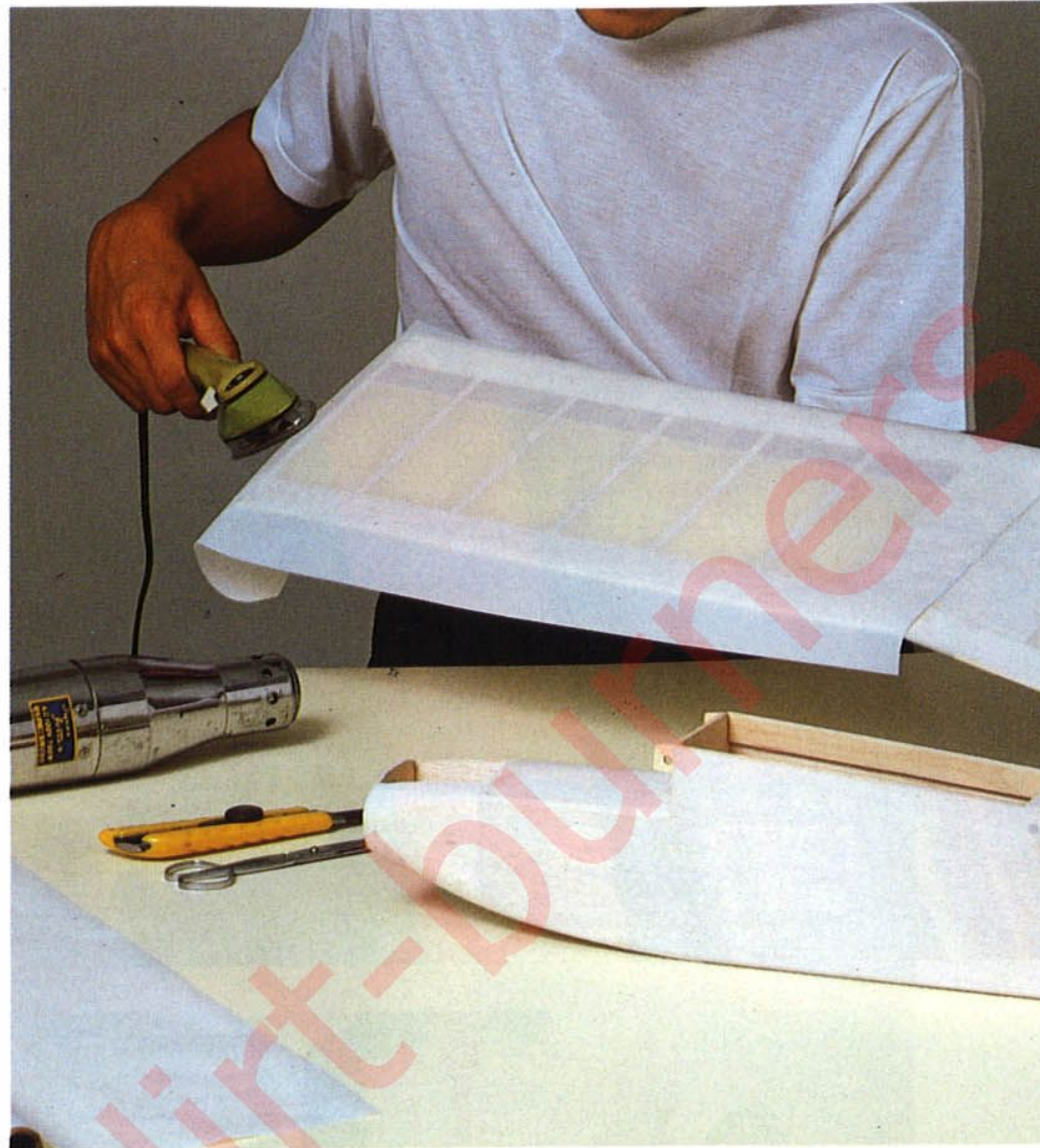



SÄLJS EJ I SVERIGE



- ① No.8150 K & B POLYESTER RESIN
- ② No.8151 K & B POLYESTER RESIN HARDENER
- ③ No.8163 K & B MICRO-BALLOONS FILLER
- ④ No.8172 K & B MEASURING MIXING CUPS
- ⑤ No.8121 K & B SUPER POXY THINNER
- ⑥ SUPER POXY
- ⑦ No.1039 MIDWEST MICROGLAS



No.1884 COATING POXY

FOR JAPANESE MARKET ONLY
Nur für den japanischen Markt

EPOXY COATING AND ADHESIVE RESIN.

COATING POXY has been formulated specially to provide a foundation for the highest quality on any model. It is noteworthy for its very low viscosity that brushes into a thin layer. When cured it has a beautiful glossy, strong, and fuel-proof finish.

SPECIAL PROP DRIVE UNITS 360PT • 240S

SPECIALLY DESIGNED FOR ELECTRIC POWERED AIRCRAFT MODELS

(360PT) No. 4075
(240S) No. 4076



360PT

■ SPECIAL PROP DRIVE UNITS

KYOSHO OFFERS TWO HIGH-PERFORMANCE DRIVE UNITS OPTIMALLY DESIGNED FOR POWERING ELECTRIC AIRCRAFT MODELS WITH A 7.2V NiCd CAR-TYPE BATTERY PACK. MODEL 360PT IS DESIGNED FOR A MOTOR RUN OF 4-6 MINUTES WITH HIGH-TORQUE OUTPUT. MODEL 240S RUNS 2-3 MINUTES AT HIGHER SPEED FOR HIGH-HORSEPOWER, TOP SPEED REQUIREMENTS. BOTH UNITS ARE COMPLETE AND READY TO INSTALL IN A MODEL, COMPRISING A HIGH-QUALITY KYOSHO MOTOR (360PT OR 240S), A GEAR UNIT WITH RATIOS SELECTED FOR BEST PERFORMANCE FROM THE MOTOR, PROPELLER COMBINATION, A SPECIAL 9-4 WIDE-BLADE PROPELLER DESIGNED FOR BEST PERFORMANCE WITH ELECTRIC MOTORS, WIRING, A SWITCH, A BATTERY CONNECTOR AND A SPINNER.

MOTORER FÖR ELFLYG

Kyosho har nu under flera år utvecklat elmotorer, växellådor och propellrar för att uppnå bästa funktion och verkningsgrad i flygande modeller. De här motorerna finns också att köpa löst. Den lilla AP29 motorn finns att få både bronslagrad (1929) och dubbelt kullagrad (1930) för den som så önskar.

Det finns dessutom en komplett elflygsats att tillgå för Dig som vill sätta elmotor i Din egen modell. Satsen innehåller allt från strömbrytare till propeller och dessutom den starka och kullagarade LeMans 360PT motorn. Det här är, så när som på den vassare motorn, exakt samma utrustning som sitter i den välkända Etude modellen. Art nr 4075.

Varianten med 240S motor levereras ej i Sverige.

LeMANS AP29 No.1929

HIGH-TORQUE TYPE CUSTOM DESIGNED FOR MEDIUM-SIZE MODEL AIRPLANES. ALSO SUITABLE FOR BOATS.



LeMANS AP29BB No.1930

SPECIAL HIGH-PERFORMANCE VERSION OF AP29, WITH TWIN BALL BEARINGS FOR MAXIMUM SPEED AND POWER.



240S

DIGITAL PROPORTIONAL RADIO CONTROL SYSTEMS

IMPULSE II RADIO CONTROL SYSTEMS

HIGH-QUALITY TWO-CH SYSTEMS. SAME TRANSMITTER IN ALL SETS, WITH GOOD RANGE AND CLEAN SIGNAL. BATTERY VOLTAGE METER. SERVO REVERSING ON BOTH CHANNELS. RECEIVERS (TWO TYPES) DESIGNED FOR GOOD SENSITIVITY AND SPURIOUS SIGNAL REJECTION. SERVOS COMBINE SMALL SIZE AND GOOD POWER.

IMPULS II RADIOANLÄGGNING

Det här en tvåkanals radio uppbyggd runt en robust sändare och med mottagarenheter av

olika typer. För närvarande levereras endast en typ till Sverige. Det är den variant som är avsedd för modellerna i det s k "minisortimentet".



SYSTEM No.2548

THE "STANDARD" SET. LIGHTWEIGHT RECEIVER AND TWO MINI SERVOS. AVAILABLE ON 72MHZ FREQUENCIES FOR MODEL AIRCRAFT.

SYSTEM No.2546

CUSTOM DESIGNED FOR BAJA BUGS AND SIMILAR CARS. RECEIVER/ELECTRONIC SPEED CONTROLLER IN SINGLE MINIATURE UNIT PLUS ONE MINI SERVO. FORWARD/REVERSE SPEED CONTROL. 27MHZ AND 75MHZ.

Komplett anläggning med RS-enhet bestående av mottagare sammanbyggd med ett elektroniskt fartreglage och ett separat servo för styrningen.

SYSTEM No.2547

CUSTOM DESIGNED FOR 1/8-SCALE MOTORCYCLES (No.3002, ETC.). LIKE SYSTEM No.2546, BUT FORWARD SPEED CONTROL AND BRAKE. 27MHZ AND 75MHZ.

SÄLJS EJ I SVERIGE

SYSTEM No.2545

SAME SPECS AS No.2548, BUT FOR 75MHZ AND 27MHZ (FOR SURFACE MODELS).

SÄLJS EJ I SVERIGE

SÄLJS EJ I SVERIGE

PULSAR PRO 2000 AND EXP 2001 RADIO CONTROL SYSTEMS

FEATURES OF PRO 2000 AND EXP 2001: HIGH QUALITY AT REASONABLE COST. DESIGNED FOR MAXIMUM RESISTANCE TO CROSS-MODULATION FOR SOLID CONTROL. SERVO REVERSING ON BOTH CHANNELS. POSITION WHEEL ON EITHER SIDE FOR RIGHT OR LEFT HANDERS. BALANCED TO ELIMINATE WRIST FATIGUE. JACK FOR RECHARGING NiCd CELLS. (BATTERIES NOT INCLUDED). BEC FEATURE TO ELIMINATE Rx BATTERY. BATTERY METER. 27MHZ AND 75MHZ FREQUENCIES. FOR CARS AND BOATS.

PULSAR PRO & EXP RADIOANLÄGGNINGAR

Pulsar säljs i Sverige i två utföranden, båda utrustade med standard mottagare och två servon. Basutförandet heter PRO och sändaren är här utrustad med samma basfunktioner

som Impuls II, alltså servoreversering, batterimätare, laddjack etc. Den mer avancerade EXP har dessutom exponetialomkoppling och utslagsbegränsning på båda kanalerna.



No.2555: EXP 2001 TRANSMITTER, RECEIVER, TWO SERVOS

Komplett anläggning med Pulsar EXP sändare.



No.2556: PRO 2000 TRANSMITTER, RECEIVER, TWO SERVOS

Komplett anläggning med Pulsar PRO sändare.



No.2557: PRO 2000 TRANSMITTER PLUS RECEIVER/CONTROLLER/SERVO SET No.2566 FOR MINI CARS

SÄLJS EJ I SVERIGE



No.2558: PRO 2000 TRANSMITTER PLUS RECEIVER/CONTROLLER/SERVO SET No.2567 FOR MINI MOTORCYCLES.

SÄLJS EJ I SVERIGE

ELECTRONIC SPEED CONTROLLERS AND ACCESSORIES



RECEIVER/CONTROLLER/SERVO UNIT NO.2566

MINIATURE RECEIVER/ELECTRONIC SPEED CONTROLLER UNIT AND MINI SERVO AS USED IN SYSTEM NO.2546. USE WITH ANY IMPULSE II, PULSAR, OR OTHER AM TRANSMITTER OF SAME FREQUENCY.

RS-ENHET MED BACK

RS-enheten består av ett styrservo sammankopplat med en enhet innehållande mottagare och fartreglage med fram/back funktion.

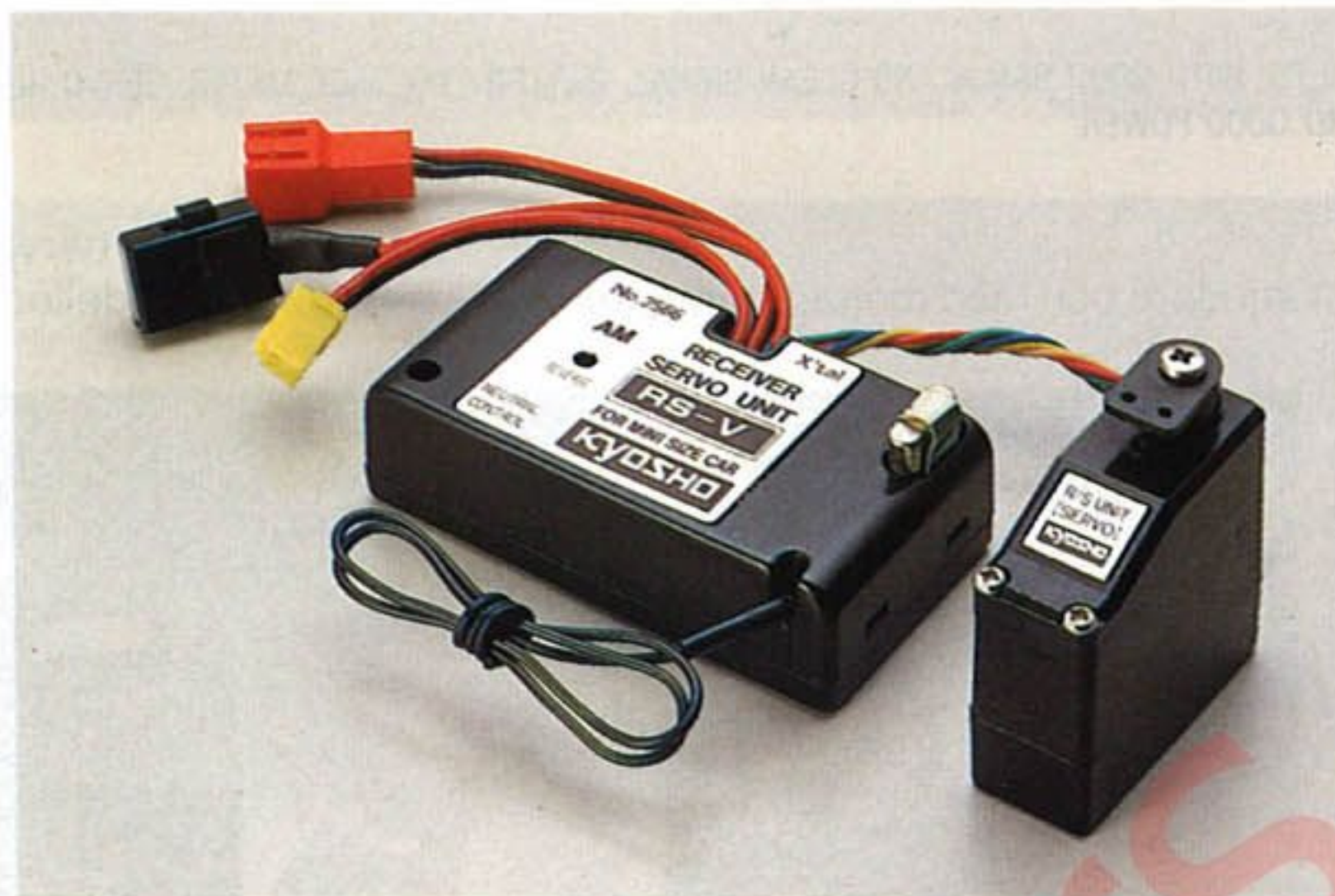

RECEIVER/CONTROLLER/SERVO UNIT No.2567

MINIATURE RECEIVER/ELECTRONIC SPEED CONTROLLER UNIT AND MINI SERVO AS USED IN SYSTEM No.2547. USE WITH ANY IMPULSE II. PULSAR, OR OTHER AM TRANSMITTER OF SAME FREQUENCY.

RS-ENHET MED BROMS

RS-enheten består av ett styrservo sammankopplat med en enhet innehållande mottagare och fartreglage med bromsfunktion.

- NO.2593KY: KYOSHO CONNECTOR
- NO.2593FG: FUTABA "G" CONNECTOR
- NO.2593FJ: FUTABA "J" CONNECTOR
- NO.2593KO: KO CONNECTOR
- NO.2593SW: SANWA CONNECTOR

SUPER-SPEED 1000 ELECTRONIC SPEED CONTROLLER No.2593

SOLID-STATE POWER-FET SIMPLICITY AND RELIABILITY FOR CONTROLLING ELECTRIC MOTORS OF MODEL CARS, AIRPLANES, AND BOATS. LIGHTER AND LESS COMPLEX THAN COMBINED SERVO AND MECHANICAL CONTROLLER; JUST PLUG SPEED CONTROLLER INTO RECEIVER. SPEED CONTROL AND BRAKING FUNCTIONS. ADJUSTABLE RESPONSE. MAXIMUM CONTINUOUS CURRENT RATING OF 210 AMPS (MORE THAN 6 TIMES THE NORMAL CURRENT OF A HIGH-POWER MOTOR), AND MAXIMUM PEAK OF 1260 AMPS. VERY LOW POWER LOSS, ONLY 0.004 VOLTS PER AMP. FOR 6 TO 9.6V BATTERIES. WEIGHT ONLY ABOUT 40g.

FARTREGLAGE FÖR RACINGBRUK

Det här är ett avancerat elektroniskt fartreglage avsett för tävlingsbuggy och banbilar. Spänningsfallet är så lågt som 0.004 V/A för bästa bilprestanda

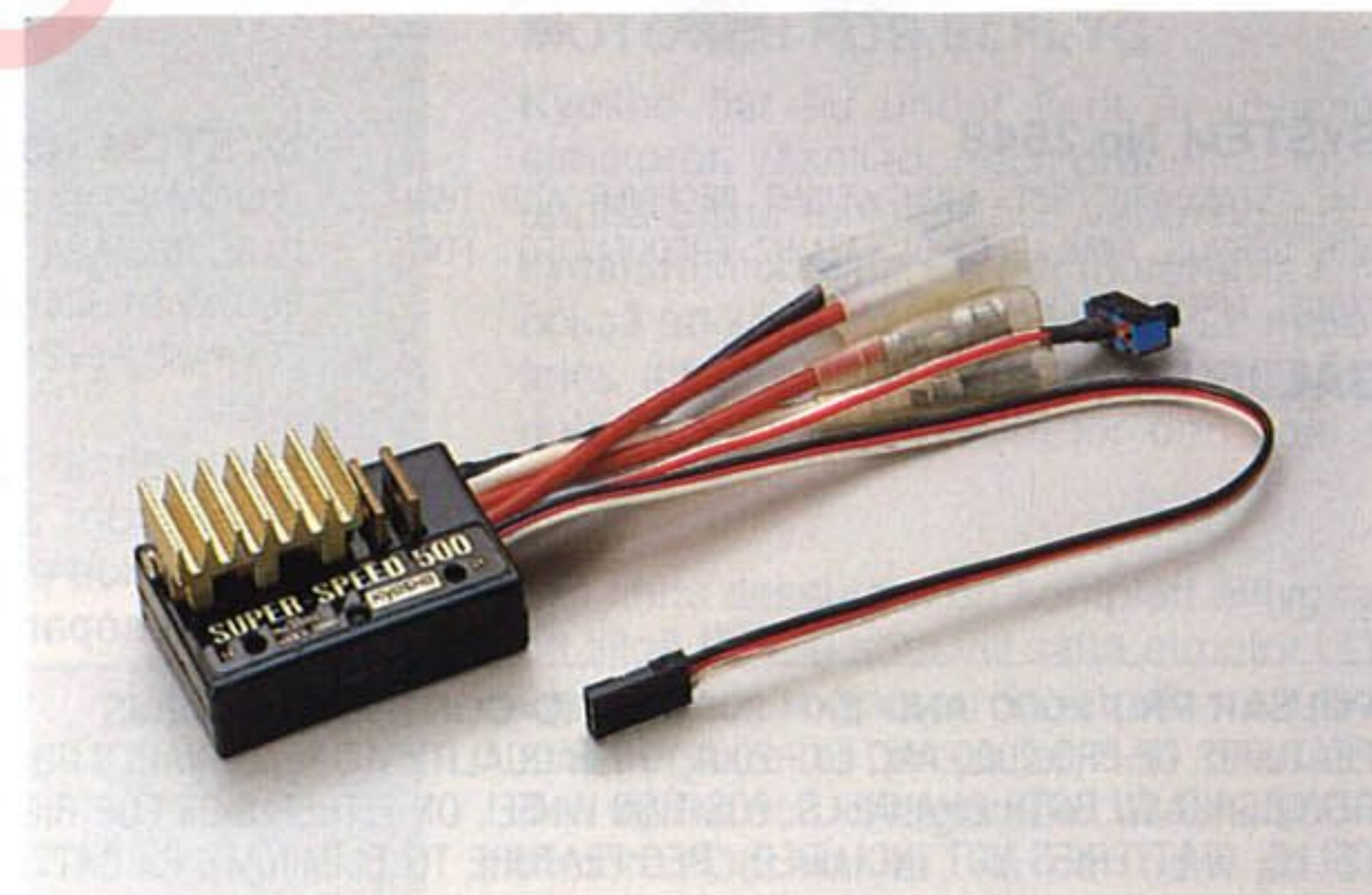

SUPER-SPEED 500 ELECTRONIC SPEED CONTROLLER No.2592

SAME FEATURES AS SUPER-SPEED 1000, EXCEPT MAXIMUM CONTINUOUS CURRENT IS 90 AMPS, AND VOLTAGE LOSS IS 0.015 V/A.

FARTREGLAGE FÖR BANELBIL

Det här lilla reglaget är i första hand avsett för banelbilar och det har ett spänningfall på bara 0.015 V/A.

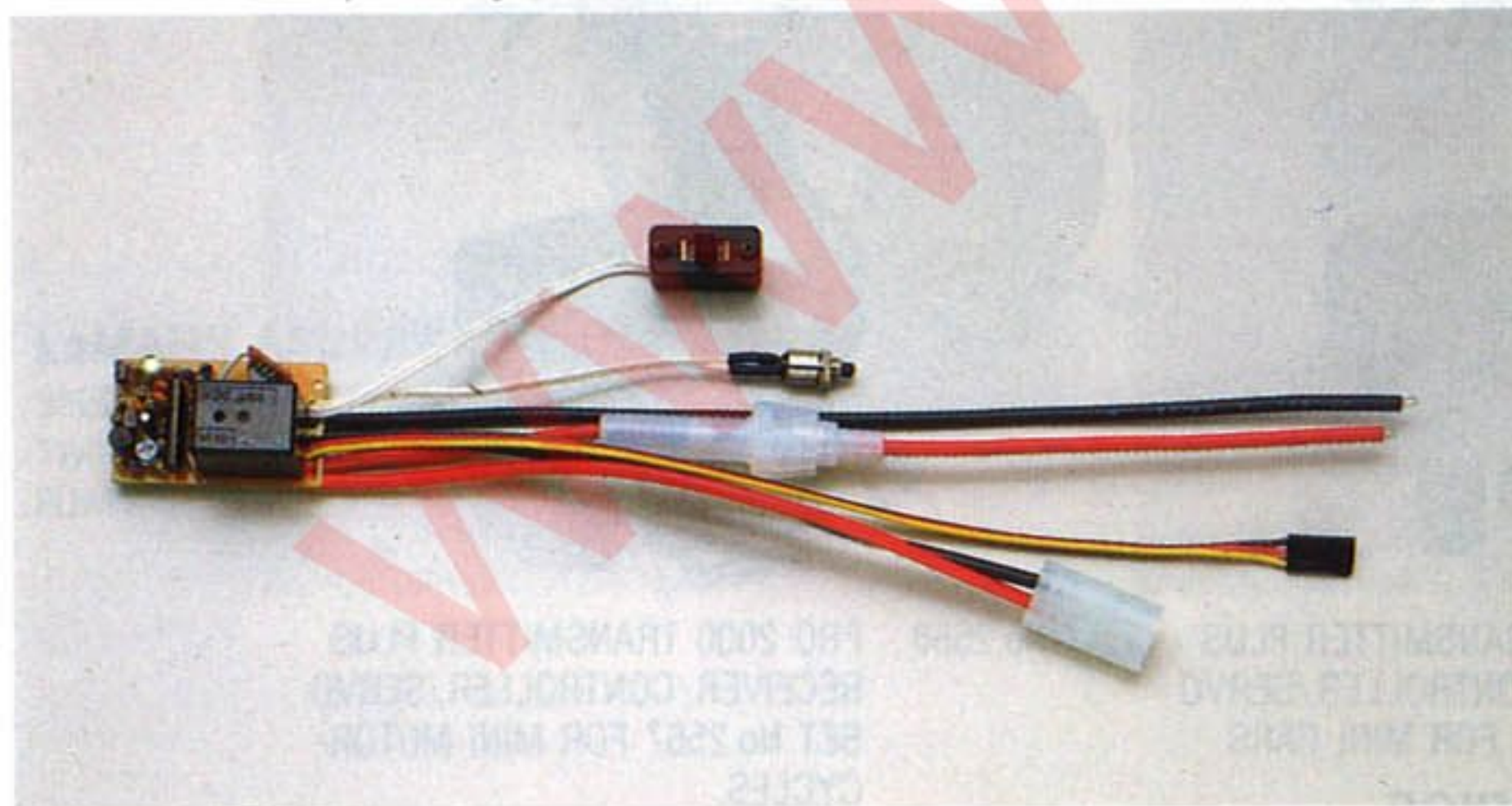

AUTO CUTOFF RELAY WITH ON-OFF MOTOR CONTROLLER

ALLOWS SWITCHING MOTOR OF ELECTRIC AIRCRAFT ON/OFF REPEATEDLY IN FLIGHT. WHEN BATTERY RUNS LOW, CUTOFF UNIT SWITCHES MOTOR OFF, KEEPING ENOUGH POWER IN RESERVE TO CONTROL MODEL.

AUTO CUT-OFF RELÄ FÖR FLYG

Det här lilla reläet gör det möjligt för Dig att använda samma ack-paket till Din flygradio som till flygplanets motor. Den insparade vikten betyder bättre flygegenskaper. Reläet kopplar automatiskt bort motorn när det fortfarande finns tillräckligt med ström för att flyga ner modellen utan motor.

- NO.1811: FUTABA "J" CONNECTORS
- NO.1812: FUTABA "G" CONNECTORS
- NO.1813: AIRTRONICS CONNECTORS

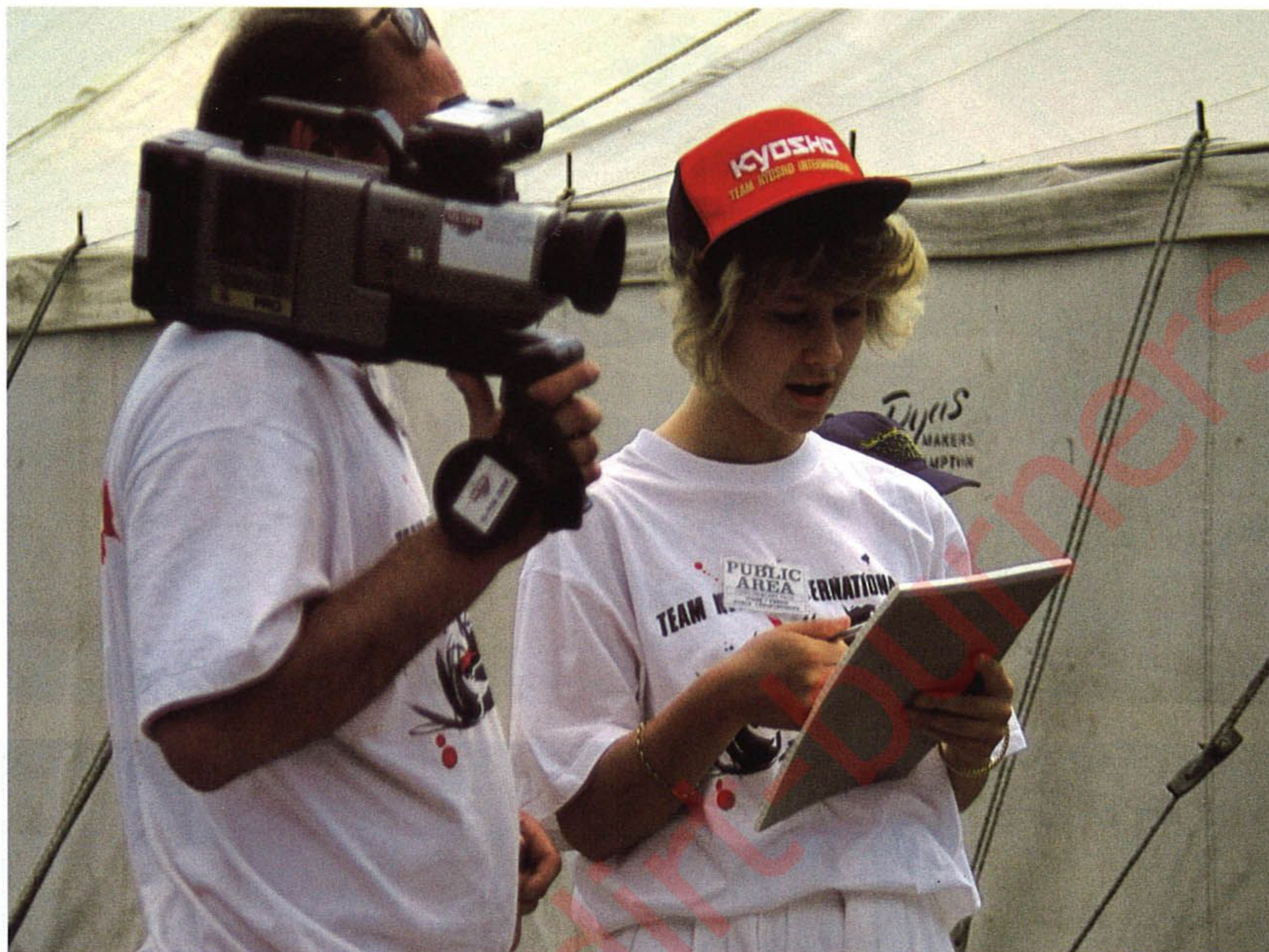

WAIST POUCH No.4087KY



KYOSHO ORIGINAL CAP No.4108



KYOSHO ORIGINAL T-SHIRT (M)(L) No.4111

KYOSHO ORIGINALS



R/C CHAIR BAG (M) No.4114
R/C CHAIR BAG (L) No.4124



R/C BAG No.4125



TOOL BOX No.4139



PARTS BOX (M) No.4138



PARTS BOX (S) No.4137

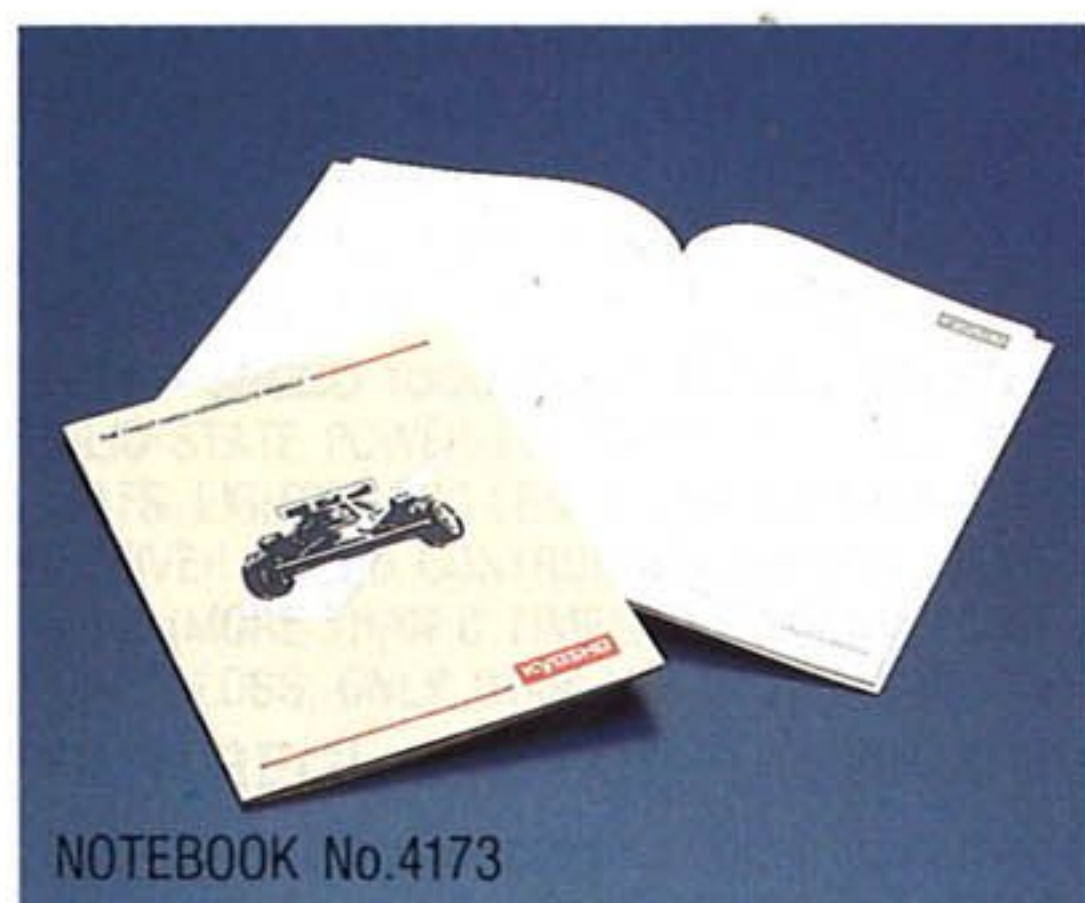

NOTEBOOK No.4173

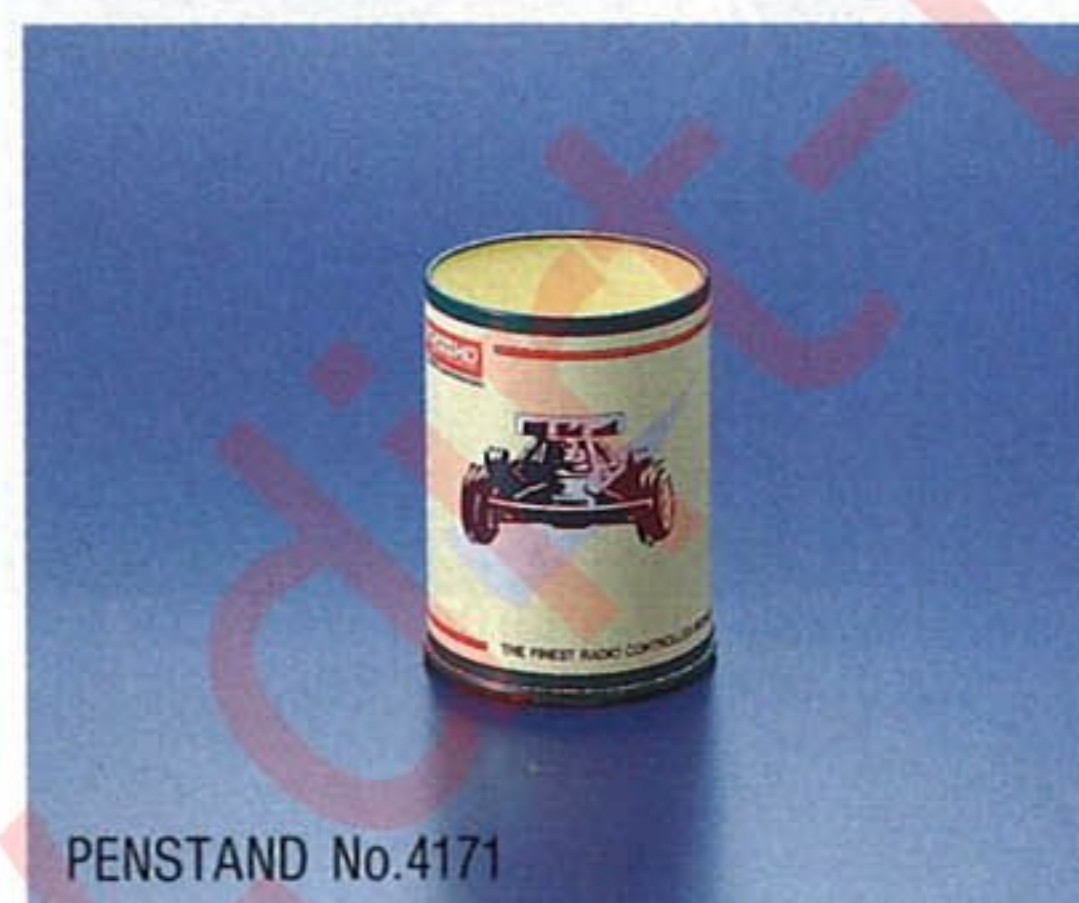

PENSTAND No.4171

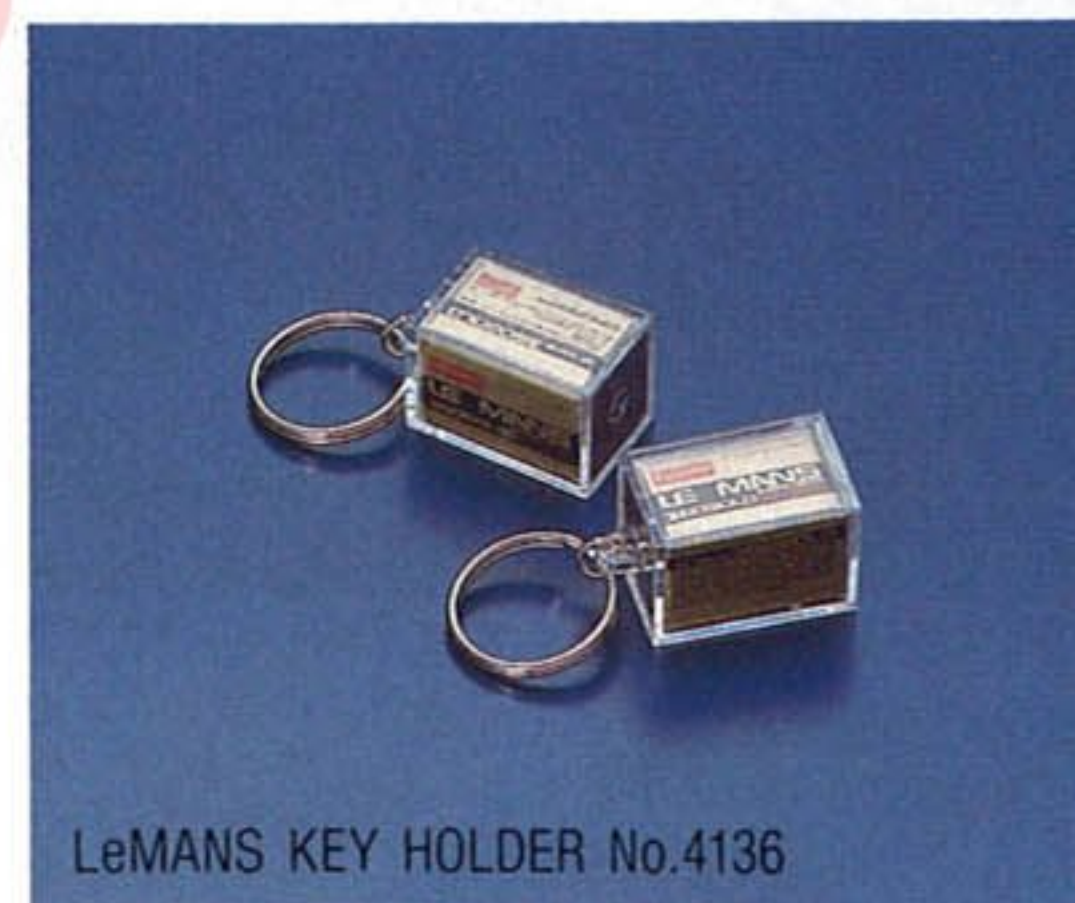

LeMANS KEY HOLDER No.4136

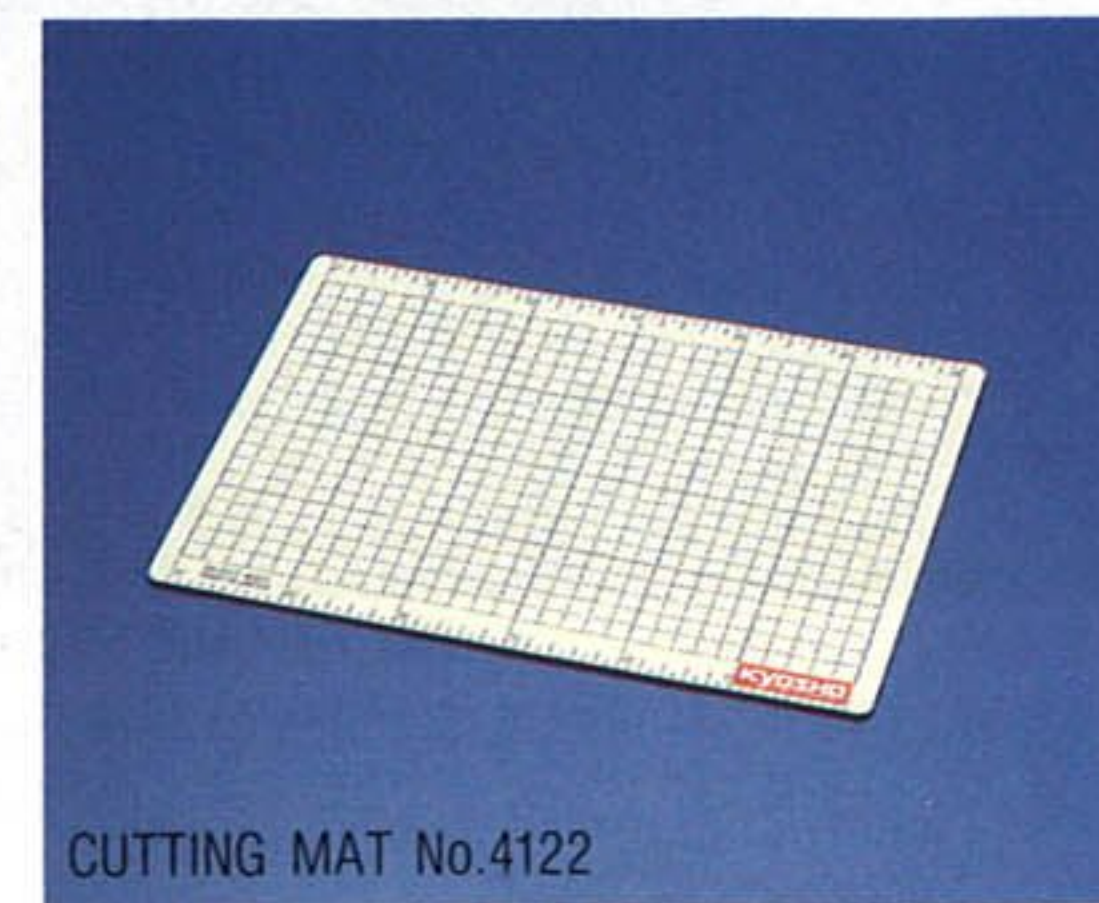

CUTTING MAT No.4122

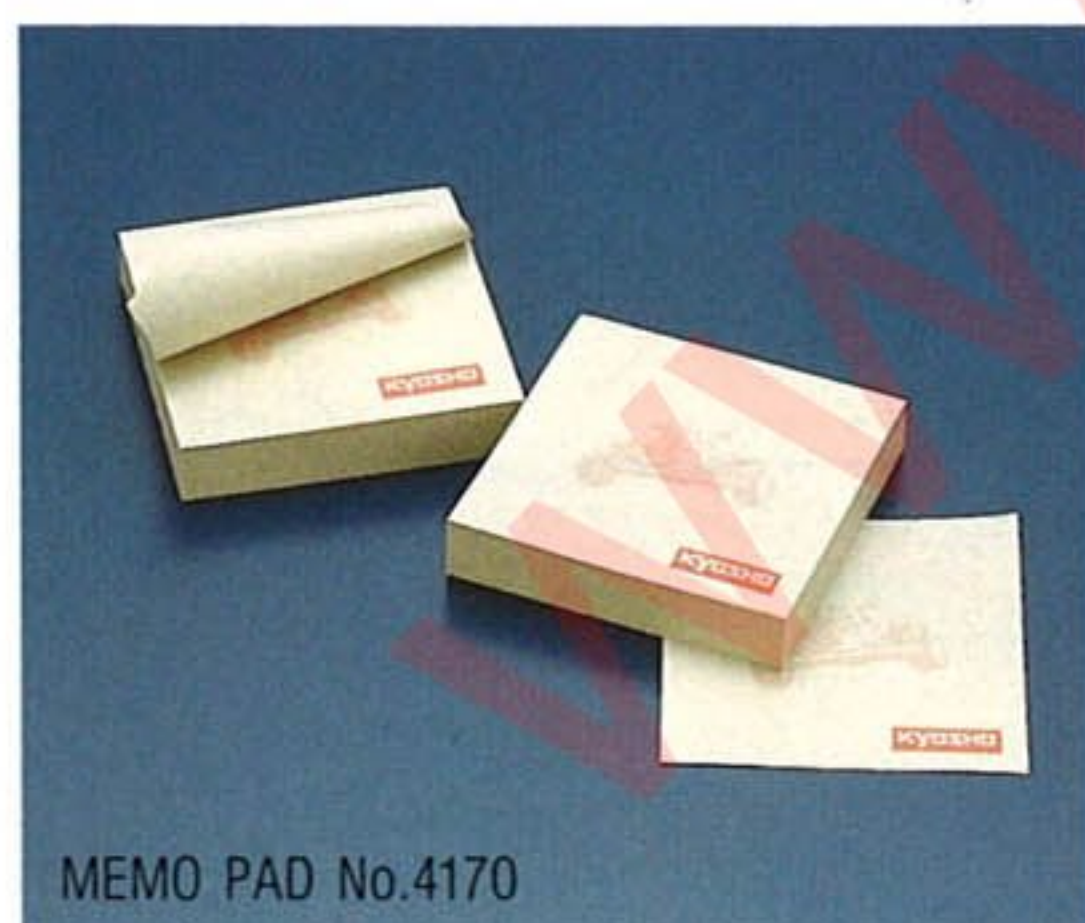

MEMO PAD No.4170

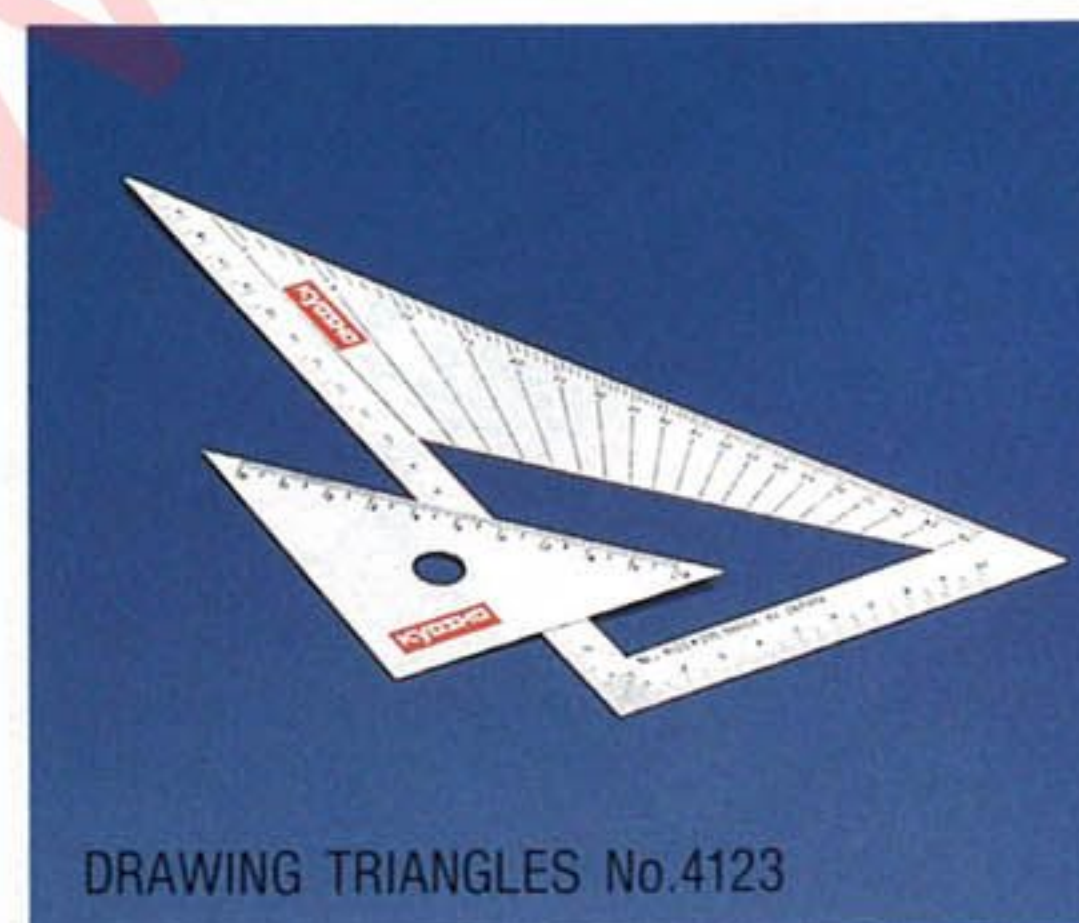

DRAWING TRIANGLES No.4123



VINYL POUCH No.4172



BAG No.4126



(S)(M)(L)
"KYOSHO" LOGO-TYPED STICKERS



SUN CAP No.4117



MINI BANNERETS No.4140



DESIGNER PAPER BAG No.4127

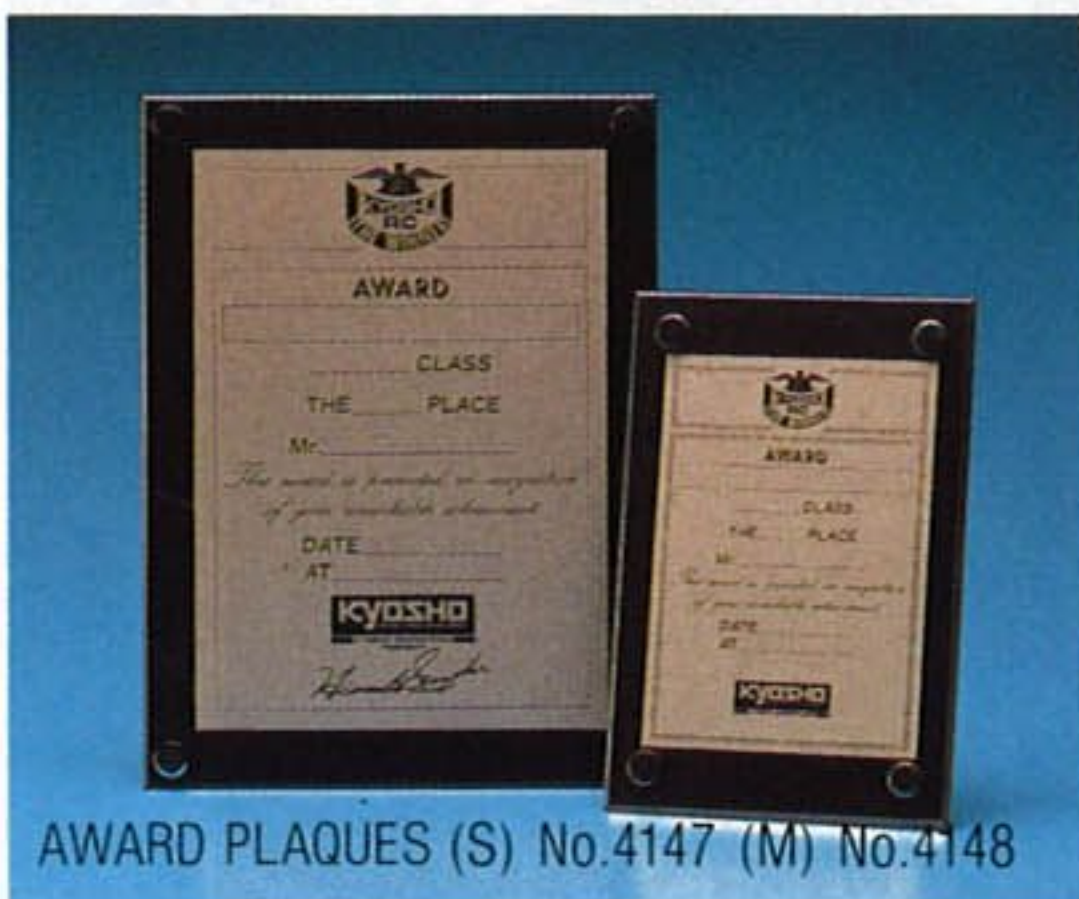

AWARD PLAQUES (S) No.4147 (M) No.4148



BANNERS FOR RACE COURSE No.4144

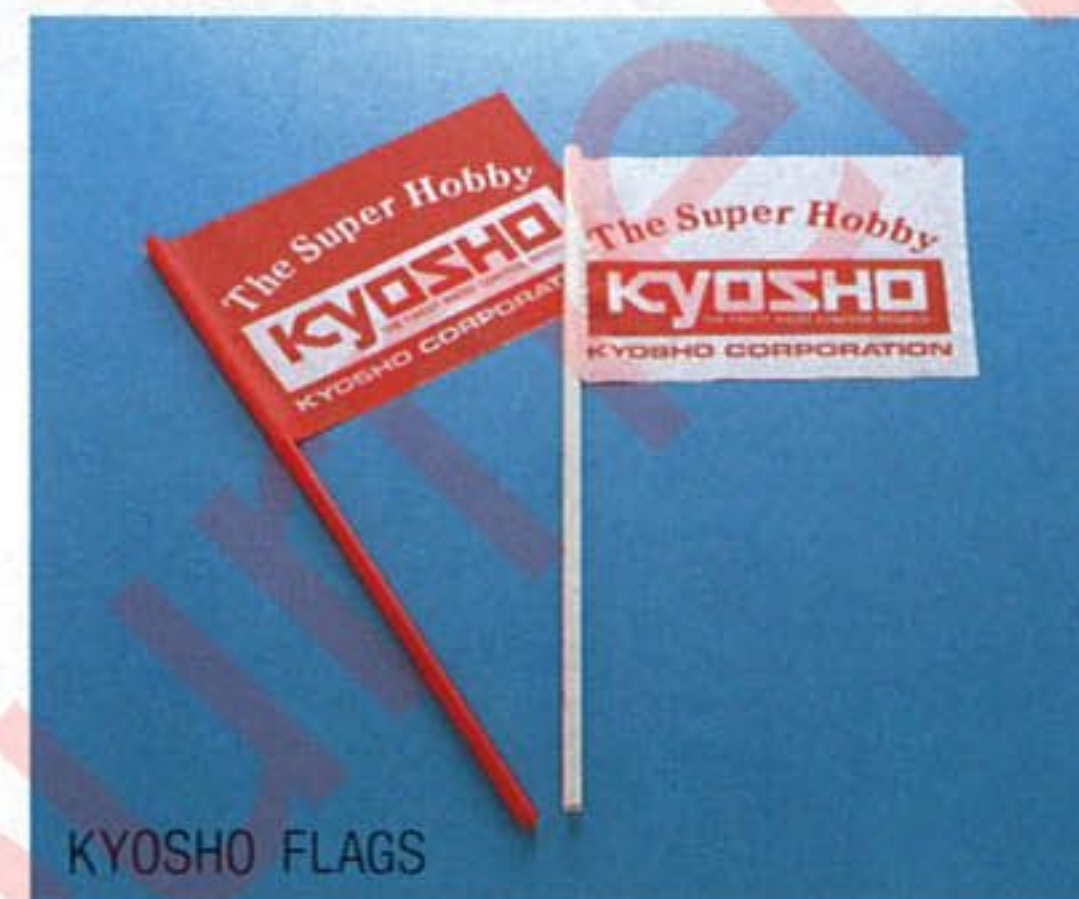

KYOSHO FLAGS



RACING NUMBERED BIBS
(No.1~No.50) No.4145
(No.1~No.150) No.4146B

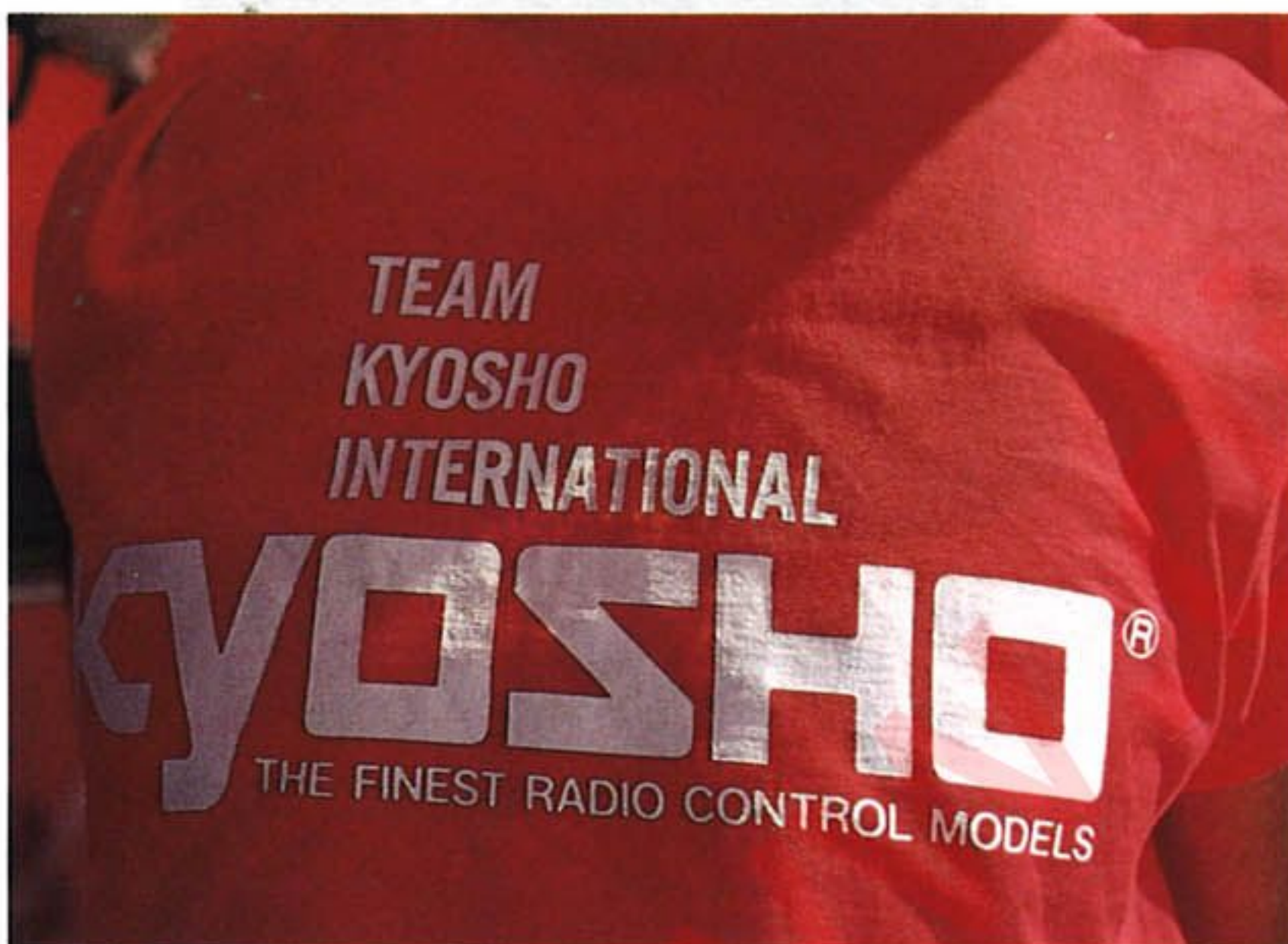

ENTRY CARDS



BANNERS

"KYOSHO" LOGO-TYPED BANNER



POPCRAFT

THEY'RE NEW! THEY'RE ORIGINAL! POP-CRAFTS!

FUN TO BUILD! DECORATIVE AND CUTE, WITH A HIGH-TECH FLAVOR! THE *ELECTRO-GUARD TIKI* SITS ON YOUR SHELF AND DESK, AND WARNS YOU WHEN SOMEONE IS COMING. THERE'S NO TAPE RECORDER OR OTHER MECHANICAL COMPLEXITY, JUST THE MODERN MIRACLE INTEGRATED CIRCUIT- THE VOICE SYNTHESIZER. *TIKI* BRINGS THIS HIGH TECHNOLOGY TO A FUN APPLICATION!

THE *ELECTRO-LIGHTS* ARE SOUND SENSITIVE. JUST SPEAK OR CLAP YOUR HANDS, AND THE LIGHT GOES ON OR OFF. HANDY FOR FINDING YOUR WAY AROUND A DARK ROOM! RACY HELMET *HEL-LIGHT* AND GENTLE *LADY BUG*.

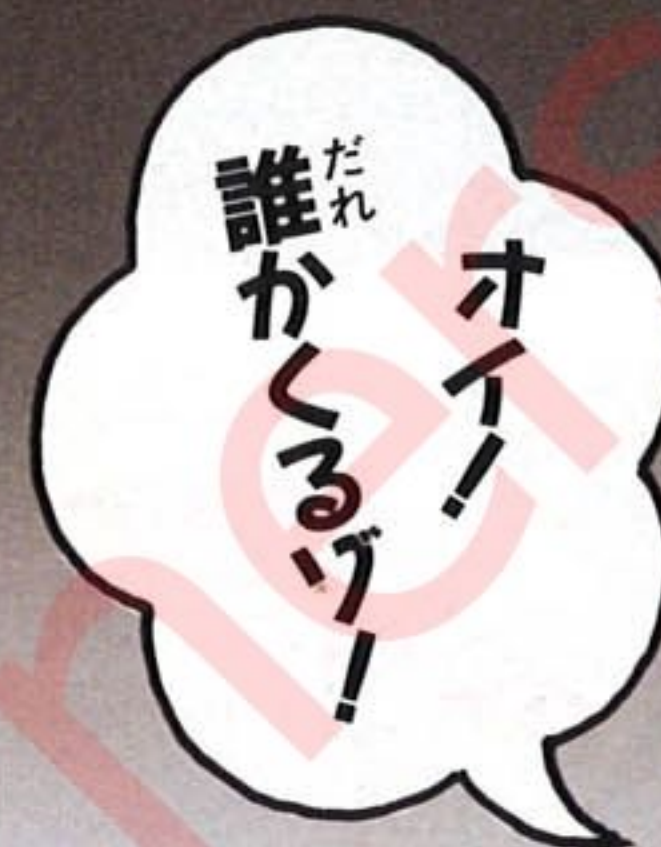
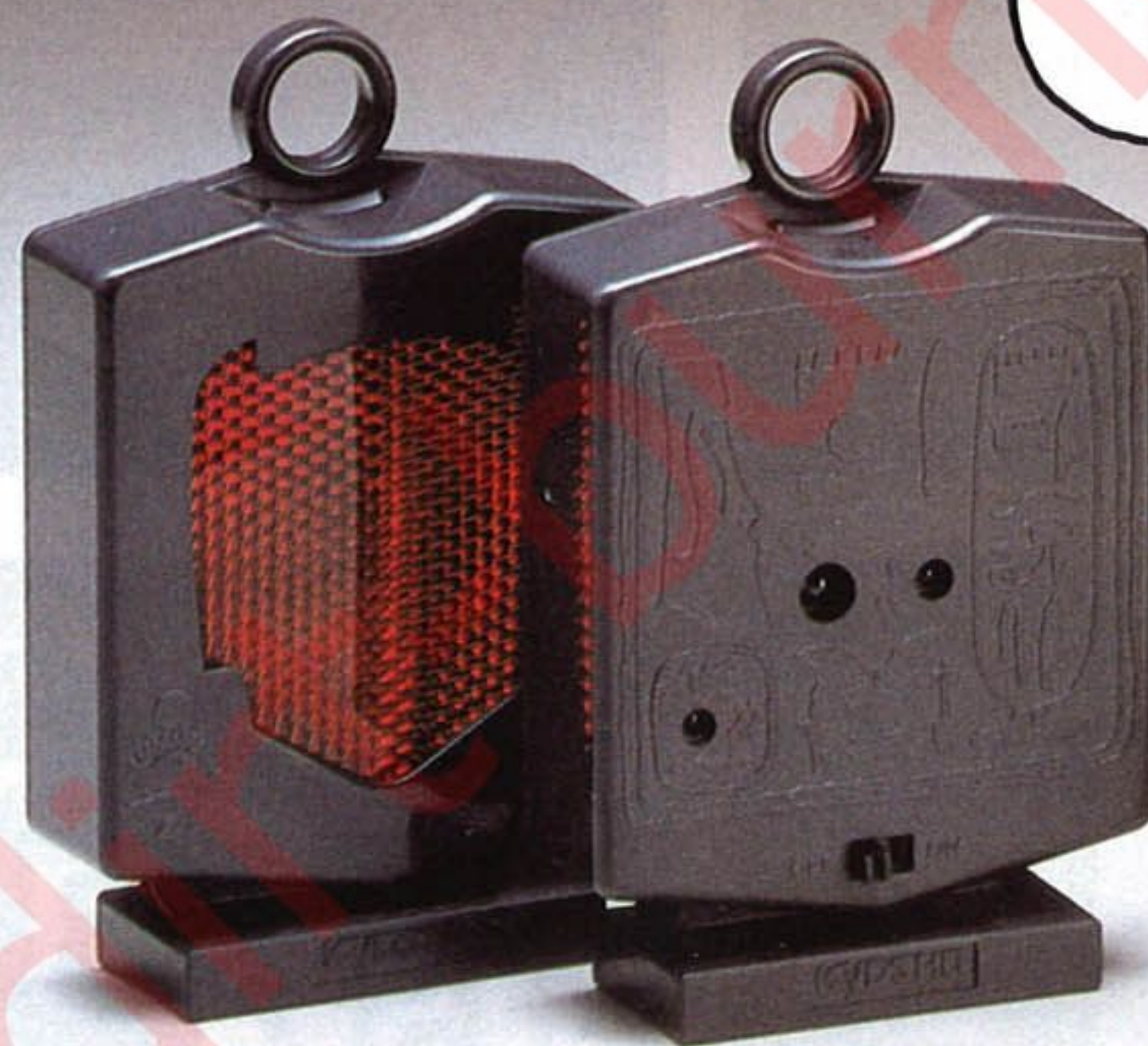

ELECTRO-GUARD TIKI

TIKI IS A WORK OF ART, SYMBOL OF THE MYSTERY OF EASTER ISLAND! HE ALSO STANDS GUARD, WARNING WHEN AN INTRUDER IS TRYING TO APPROACH! *TIKI* ACTUALLY SPEAKS HIS VOICE-SYNTHESIZED ELECTRONIC WARNING. FASCINATING! HIS SENSORS OPERATE WITH INVISIBLE INFRA-RED RAYS, SO THE INTRUDER CAN'T SEE THE SENSOR BEAM.

TWO VERSIONS. No.9011 GIVES THE FUN OF ASSEMBLING YOUR OWN *TIKI*. THIS TAKES ONLY A COUPLE OF HOURS, AND REQUIRES NO TOOLS OR ADHESIVES. THE CIRCUIT BOARDS FOR THE VOICE SYNTHESIZER AND SENSOR UNITS ARE ALREADY MADE AND TESTED, SO THEY WILL WORK THE FIRST TIME. KIT ALSO INCLUDES BATTERY HOLDER, TWO AA-SIZE PENCCELLS, SENSOR AND REFLECTOR HOUSINGS, SPEAKER, ETC. KIT No.9012 IS FACTORY MADE AND READY TO USE AT ONCE.





ELECTRO-LIGHT HEL-LIGHT

SYMBOL OF MOTORCYCLING FREEDOM, THE *HEL-LIGHT* LOOKS GREAT IN ANY YOUNG PERSON'S ROOM! CLAP YOUR HANDS OR SNAP YOUR FINGERS AND THE LIGHT GOES ON! DO IT AGAIN AND THE LIGHT GOES OFF! HANDY AT NIGHT FOR FINDING YOUR WAY AROUND A DARK ROOM, AND AN "ALWAYS THERE" COMPANION WHEN THE ROOM IS JUST A BIT TOO DARK.

TWO VERSIONS. KITS No.9001 (RED) AND 9002 (BLACK) GIVE THE FUN OF ASSEMBLING THE PARTS AND APPLYING THE DECORATIVE STICKERS. KIT No.9003 (RED) AND 9004 (BLACK) ARE FACTORY ASSEMBLED AND READY TO USE. TWO C-SIZE CELLS INCLUDED.

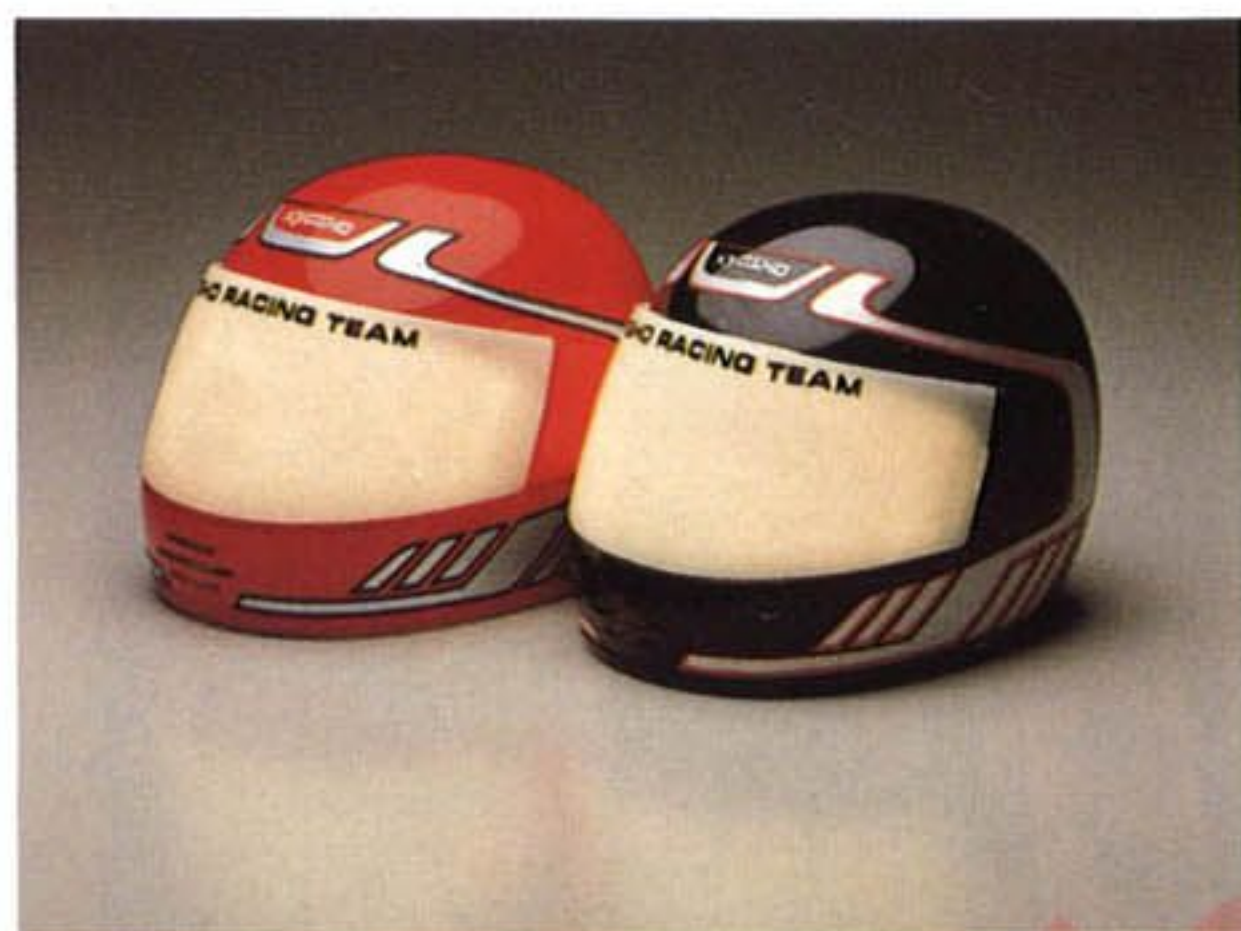

ELECTRO-LIGHT LADY BUG

EVERYBODY LOVES THE *LADY BUG*! GENTLE, COMFORTING, COLORFUL, AND CUTE! *LADY BUG* IS ALWAYS THERE, A CONSTANT COMPANION. LONELY AT NIGHT? FINDING YOUR WAY AROUND A DARK ROOM? JUST CLAP YOUR HANDS OR SNAP YOUR FINGERS, AND *LADY BUG* IS THERE WITH HER GENTLE GLOW OF REASSURANCE. TWO VERSIONS. KIT No.9006 GIVES YOU THE FUN OF MAKING YOUR OWN *LADY BUG*. THE SOUND-SENSITIVE CIRCUIT BOARD IS ALREADY ASSEMBLED AND TESTED, AND THE FEW COMPONENTS CAN BE ASSEMBLED IN A SHORT TIME. KIT INCLUDES BATTERY HOLDER AND TWO C-SIZE CELLS. KIT No.9007 IS ALREADY ASSEMBLED AND READY TO OPERATE AS SOON AS YOU PUT THE BATTERIES IN.





■ HEAD OFFICE



■ ATSUGI OPERATION CENTER



KYOSHO CORPORATION

ATSUGI OPERATION CENTER

153, FUNAKO NAGAKA-MACHI, ATSUGI, KANAGAWA 243, JAPAN

TELEPHONE:0462-29-1511

TELEFAX:0462-29-5033 TELEX:J47979 KYOSHO

HEAD OFFICE

1-9-3 HIRAKAWA-CHO, CHIYODA-KU, TOKYO 102, JAPAN

TELEPHONE:03-264-4111

www.dirt-burners.com

AB SLOT CAR

BOX 30191, 104 25 STOCKHOLM

TELEFON 08-53 57 30